

Genie® S®-80 J & S-80 J TraX™

Specifications

Models	S-80 J & S-80 J TraX	
Measurements	US	Metric
Working height max. ⁽¹⁾	86 ft 5 in	26.51 m
Working height max.(TraX) ⁽¹⁾	86 ft 7 in	26.56 m
Platform height max.	80 ft 5 in	24.51 m
Platform height max.(TraX)	80 ft 7 in	24.56 m
Horizontal reach max.	54 ft 9 in	16.69 m
A Platform length (8 ft/6 ft)	3 ft/2 ft 6 in	0.91 m/0.76 m
B Platform width (8 ft/6 ft)	8 ft/6 ft	2.44 m/1.83 m
C Height - stowed (tires)	9 ft	2.74 m
C Height - stowed (TraX)	9 ft 4 in	2.84 m
D Length - stowed (tires)	34 ft 3 in	10.44 m
D Length - stowed (TraX)	34 ft 3 in	10.44 m
D Length - storage/transport (jib tucked under)	26 ft 2 in	7.98 m
E Width (tires)	8 ft 2 in	2.49 m
E Width (TraX)	8 ft 1 in	2.46 m
F Wheelbase	10 ft	3.05 m
G Ground clearance - center (tires)	14 in	0.36 m
G Ground clearance - center (TraX)	18 in	0.46 m
H Height under counterweight	3 ft 7 in	1.09 m

Productivity

Lift capacity max. - unrestricted	660 lb	300 kg
Number of Platform Occupants	2	
Platform rotation	160°	
Jib length	6 ft	1.83 m
Vertical jib rotation (up/down)	130°	
Turntable rotation	353°	
Turntable tailswing	8 ft 4 in	2.54 m
Drive speed - stowed (tires)	3.0 mph	4.8 km/h
Drive speed - stowed (TraX)	1.95 mph	3.14 km/h
Drive speed - raised (tires)	0.72 mph	1.6 km/h
Drive speed - raised (TraX)	0.63 mph	1.01 km/h
Gradeability - stowed ⁽²⁾	45%	
Tilt sensor activation (front to back/side to side)	4.5°/4.5°	
Turning radius - inside/outside (tires)	15 ft 6 in/25 ft 7.22 in	4.70 m/7.80 m
Turning radius - inside/outside (TraX)	16 ft 3.5 in/26 ft 6 in	4.97 m/8.08 m
Tires	355/55D625	
Track system - 4 points	TraX	

Power

Power		Diesel
Hydraulic tank capacity	23 gal	87 L
Fuel tank capacity	30 gal	114 L

Weight⁽³⁾ and Floor Loading⁽⁴⁾

Weight (tires)	24,500 lb	11,113 kg
Weight (TraX)	29,588 lb	13,421 kg
Tire contact pressure	91 psi	627 kPa
Track contact pressure	33 psi	227.5 kPa
Occupied floor pressure (tires)	243 psf	11.61 kPa
Occupied floor pressure (TraX)	291 psf	13.93 kPa

Sound and Vibration Levels

Sound Pressure level (ground workstation)	83.4 dBA
Sound Pressure level (platform workstation)	75.5 dBA
Vibrations	< 2.5 m/s ²

Range of motion S-80 J/S-80 J TraX

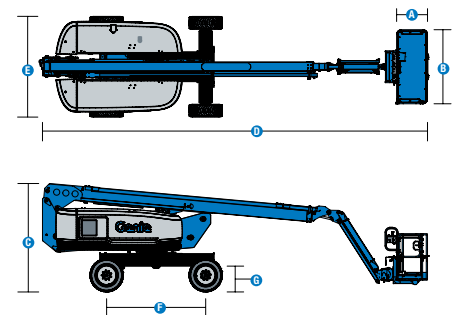
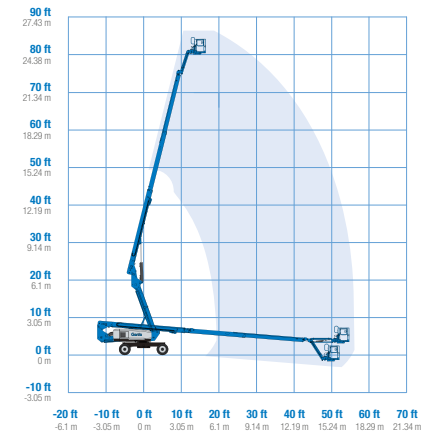

(1) The metric equivalent of working height adds 2 m to platform height. The imperial equivalent adds 6 ft to platform height.
 (2) Gradeability applies to driving on slopes and may vary depending on options and machine configurations. See operator's manual for details regarding slope ratings.
 (3) Weight refers to standard configuration and may vary depending on options and/or country standards.
 (4) Floor loading information is approximate and may vary depending on options and machine configurations. It should be used only with adequate safety factors.



HONEST, RELIABLE & REACTIVE
SOLUTIONS FOR WORKING AT HEIGHT

CONTACT US

- 0800 865 4455
- info@hiresafesolutions.com
- www.hiresafesolutions.com



Genie® S®-80 J & S-80 J TraX™

SKU: Standard Model

- **S80J0001AF0036:** S-80 J, 4WD
- **S80J0001AF0038:** S-80 J, Lift Power 12kW Welder Ready, Cold weather package, 4WD
- **S80J0001AF0037:** S-80 J, Lift Power 3kW, Cold weather package, 4WD

* Build to Order

Option availability	S	S+	BtO
Power			
49 hp, 36.5 kW, Kubota D1803, Turbo Diesel, T4f/Stage V	✓	✓	✓
Cold weather package			○
Diesel air intake pre-cleaner			○
Positive air shutdown system			○
Anti-restart engine protection	✓	✓	✓
Auto engine fault shutdown	✓	✓	✓
In cylinder glow plug (diesel only)	✓	✓	✓
Platform			
6ft/1.83m dual-entry platform with side swing gate			○
8ft/2.44m tri-entry platform with side swing gate	✓	✓	✓
Dual axis joystick steering	✓	✓	✓
Thumb rocker steering			○
Air line to platform			○
Control box covers		○	○
Lift Guard Full Mesh panels			○
Lift Guard Half Mesh panels			○
Light Package: drive and work lights		○	○
Platform auxiliary top rail			○
Lift Power 3kW AC Generator, 110V/60Hz			○
Lift Power 3kW AC Generator, 220V/50Hz			○
Lift Power 12kW Welder Ready AC Generator			○
Drive enable system	✓	✓	✓
Horn	✓	✓	✓
Lift Guard Contact Alarm	✓	✓	✓
Lift Tools Work Tray	✓	✓	✓
Platform load sense system	✓	✓	✓
Proportional controls	✓	✓	✓
Self-leveling platform	✓	✓	✓
Chassis			
Lift Connect Telematics		○	○
Telematics-ready	✓	✓	✓
Lift Connect with Access Manager upgrade		○	○
Biodegradable hydraulic oil			○
Cold weather hydraulic oil			○
Fire resistant hydraulic oil			○
Rough terrain, foam-filled tires	✓	✓	✓
Rough terrain, foam-filled, non-marking tires		○	○
TraX track drive system			○
Deluxe hostile environment kit			○
Hostile environment kit			○
2 speed wheel motors	✓	✓	✓
Active oscillating axle	✓	✓	✓
Alarm package: includes flashing beacon and travel alarm	✓	✓	✓
Chassis tilt lift and drive function cut-out	✓	✓	✓
Descent, tilt and motion alarm	✓	✓	✓
Hour meter	✓	✓	✓
Hydraulic oil cooler	✓	✓	✓
Positive traction drive	✓	✓	✓
Tech Pro Link connector	✓	✓	✓

- S Standard
- S+ Standard +
- BtO Build to Order
- ✓ Standard Features
- Options



660lb/300kg Capacity Jib



Low Transport Weight



Simple Design & Maintenance

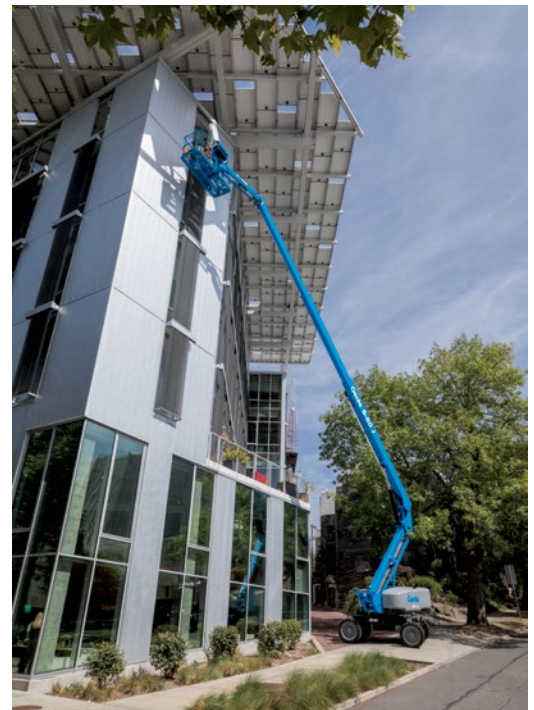

Genie Genuine Accessories⁽¹⁾

- Lift Tools Productivity Tools
- Lift Connect Telematics
- Tech Pro Link Handheld Device

(1) More accessories available from Genie Genuine Parts.

Product specifications are subject to change without notice or obligation. Photographs and/or drawings herein are for illustrative purposes only. Refer to the appropriate Operator's Manual for instructions on proper equipment use. Failure to follow instructions in the Operator's Manual may result in serious injury or death. The only warranty applicable to our equipment is the standard written warranty applicable to the particular product and sale and we make no other warranty, express or implied. Products and services listed may be trademarks, service marks or trade names of Terex Corporation and/or their subsidiaries in the USA and many other countries. Terex, Genie, Quality By Design, Xtra Capacity, Lift Power, Lift Guard, Lift Tools, Lift Connect and Tech Pro Link are registered trademarks of Terex Corporation or its subsidiaries.

09/24



HONEST, RELIABLE & REACTIVE
SOLUTIONS FOR WORKING AT HEIGHT



CONTACT US

- ☎ 0800 865 4455
- ✉ info@hiresafesolutions.com
- 🌐 www.hiresafesolutions.com

