

## ROUGH TERRAIN SCISSOR LIFTS



### COMPACT 10 / 12 DX



#### OUTSTANDING ROUGH TERRAIN DRIVING FEATURES

- > 4 wheel drive
- > Automatic differential lock
- > Excellent gradeability (40 %)
- > Ground clearance of 28 cm

#### ROBUST AND EASY TO MAINTAIN

- > Outriggers positioned within the machine footprint
- > Durable and reliable upper control box
- > Optimized accessibility to components
- > Built-in diagnostic tool

#### EXCEPTIONAL PRODUCTIVITY

- > Fully proportional controls
- > Narrow turning radius
- > One switch to deploy and retract 4 outriggers



# COMPACT 10 / 12 DX

## ROUGH TERRAIN SCISSOR LIFTS

### TECHNICAL DATA

	COMPACT 10 DX	COMPACT 12 DX
Working height	10.28 m	12.06 m
Platform height	8.28 m	10.06 m
Lift capacity	565 kg (3 pers.)	450 kg (3 pers.)
Lift capacity on the extension	150 kg	150 kg
<b>A</b> Length	3.18 m	3.18 m
<b>B</b> Width	1.78 m	1.78 m
<b>C</b> Height - stowed	2.44 m	2.56 m
<b>D</b> Wheelbase	1.84 m	1.84 m
<b>E</b> Ground clearance	28 cm	28 cm
Storage height	1.59 m	1.7 m
<b>F</b> Platform length	2.45 m	2.45 m
<b>G</b> Platform width	1.45 m	1.45 m
Extended platform length	3.7 m	3.7 m
Platform extension length	1.2 m	1.2 m
Number of extensions	1	1
Drive speed	0.6 - 5.5 km/h	0.6 - 5.5 km/h
Maximum drive height	8.15 m	8.15 m
Turning radius - outside	3.5 m	3.5 m
Lift / lower speed	35 s / 46 s	35 s / 51 s
Engine	Kubota, 18.5 kW (Stage 5 in EU)	Kubota, 18.5 kW (Stage 5 in EU)
Gradeability	40 %	40 %
Tilt alarm	3 °	3 °
Tyres - foam-filled	26 x 12 - 16.5	26 x 12 - 16.5
Hydraulic system capacity	75 l	75 l
Weight	3 350 kg	3 965 kg

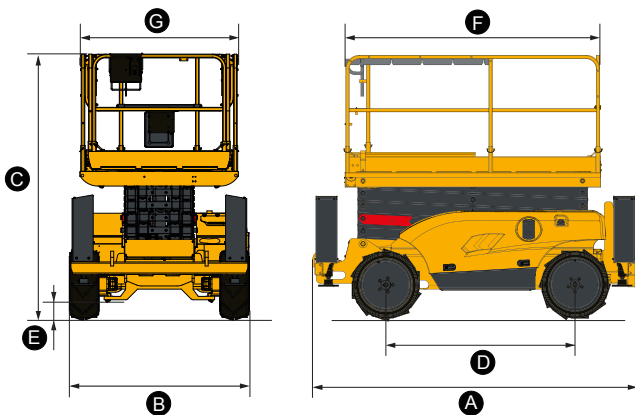

### STANDARD EQUIPMENT

- > 4 wheel drive, 2 wheel steer
- > Brake release
- > Foam filled all terrain tyres
- > 1.2 m platform extension
- > Removable operator's control box
- > 3° Tilt alarm
- > Automatic levelling outriggers
- > Horn
- > Hourmeter
- > 12 V - 70 Ah batteries
- > Hydraulic brakes
- > Manual platform lowering valve
- > Lanyard attachment points
- > Towing hooks
- > Side shields

### OPTIONS AND ACCESSORIES

- > Non marking tyres
- > 110 V power to the platform
- > Swing-door gate
- > Hydraulic generator 3.5 kW
- > Biodegradable oil
- > Cold Weather Package
- > Telematics ready
- > Motion alarm for movements and translation
- > Travel alarm
- > Rotating beacon
- > Working light
- > Foldable guard-rails

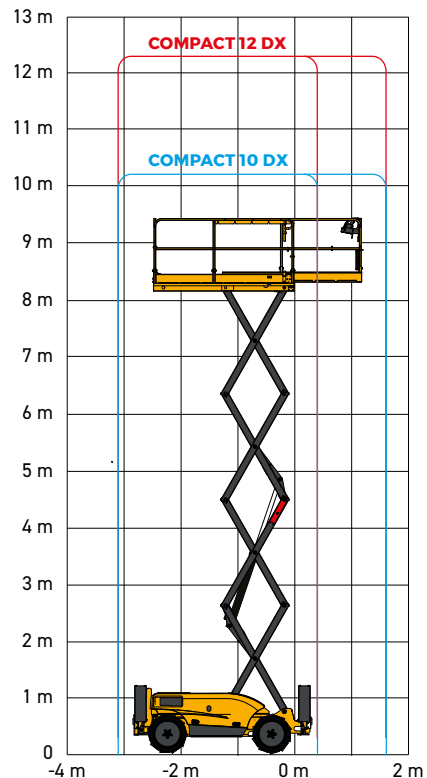

24-2006-03620 - Non contractual document - We reserve the right to modify the technical characteristics of this document without notice - 12/2020

