

**nifty**

# Heightrider

Operating & Safety Instructions

**HR28 (SP85) SERIES  
MK2**

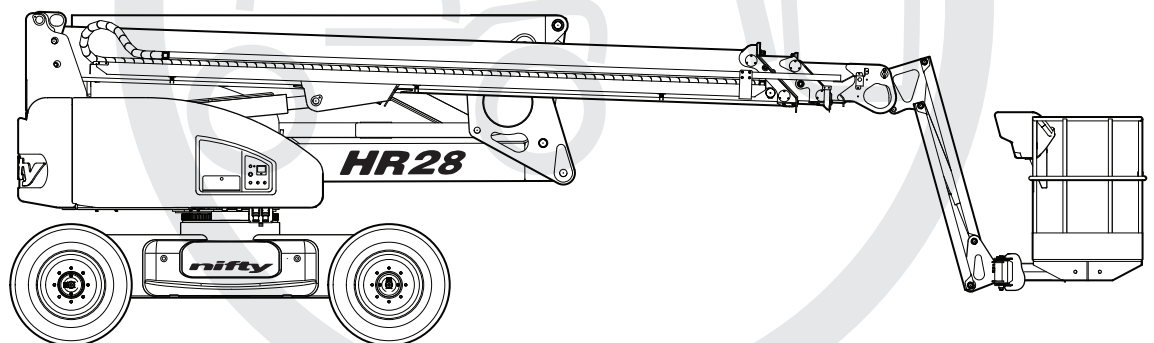

Manufactured by:  
**Niftylift Limited**  
Chalkdell Drive  
Shenley Wood  
Milton Keynes  
MK5 6GF  
England

[www.niftylift.com](http://www.niftylift.com)  
e-mail: [info@niftylift.com](mailto:info@niftylift.com)  
Tel: +44 (0)1908 223456  
Fax: +44 (0)1908 312733



**niftylift.com**  
info@niftylift.com

M50731/01



# HR28 MK2 EMERGENCY PROCEDURES

## Emergency Stop

- 1) Push in red emergency stop to shut down all machine movement.
- 2) Release both emergency stops to restore normal controls.

## Recovery from Base Controls

If normal controls are available (Fastest recovery time):

- 1) Switch to base, press green button and operate desired function lever.

If normal controls are not available:

- 2) Switch to base, press the white button and operate the desired function lever.
- 3) Release lever or white button to halt machine movement.
- 4) If the cage has contacted a fixed object and cage overload has disabled the machine, move machine slightly using step 2. The overload alarm and visual warning will cease once normal controls are available.
- 5) If normal controls are still not available, continue pressing white button to lower machine.

If normal controls are not available (Complete machine failure):

- 6) Turn key to **0** and remove key.
- 7) Open the control canopy and insert key into the Auxiliary descent key switch.
- 8) Turn key clockwise and hold in position.
- 9) Move and hold the desired boom function lever.
- 10) Release the key or boom function lever to halt machine movement.

## Recovery from Cage Controls

- 1) Press white override button situated on the cage console.  
Override mode is for **booms only** and will not operate drive.
- 2) Activate a single desired function paddle.  
(Note: Multiple boom function is not available in override mode).
- 3) If the cage has contacted a fixed object and cage overload has disabled the machine, move machine slightly using steps 1-2. The overload alarm and visual warning will cease and normal controls are available.
- 4) Use normal controls if available for fastest recovery time.  
Press green button or footswitch and operate desired function lever(s).
- 5) If normal controls are not available, continue using override button to lower machine using auxiliary power.

## SiOPS

If white button is flashing (SiOPS is active and cage is overloaded):

- 1) Follow procedure described in 'Recovery from Cage Controls' until green button flashes or normal operation is restored.

If green button is flashing (SiOPS is active):

- 2) Press flashing green button and operate cage controls to manoeuvre machine to a safe position.

To reset footswitch and normal controls:

- 1) Release load from front of console.
- 2) Ensure cage controls are in neutral position and clear of objects.
- 3) Raise foot clear of footswitch then lower foot onto footswitch to reactivate.

**Note:** If footswitch is not reset within **15 seconds**, then blue beacon on underside of cage will flash and a warning announcement will sound until footswitch is reset as described.

**For further information on all controls refer to Sections 4 and 5.**

Emergency lowering instructions vary between different types of Mobile Elevating Work Platform. Niftylift recommend that operators, site-safety personnel, and ground workers are trained in and practise these machine-specific procedures.

# Table of Contents

<b>1</b>	<b>Introduction and General Information</b>	<b>2</b>
1.1	FOREWORD .....	2
1.2	SCOPE.....	3
1.3	INTRODUCING THE HEIGHT RIDER SELF-PROPELLED (SP) SERIES .....	3
1.4	GENERAL SPECIFICATION.....	4
1.5	IDENTIFICATION (UK PLATE).....	5
1.6	EC DECLARATION OF CONFORMITY (Typical) .....	7
<b>2</b>	<b>Safety</b>	<b>8</b>
2.1	MANDATORY PRECAUTIONS .....	8
2.2	ENVIRONMENTAL LIMITATIONS.....	12
2.3	NOISE AND VIBRATION .....	12
2.4	TEST REPORT .....	13
<b>3</b>	<b>Preparation and Inspection</b>	<b>14</b>
3.1	UNPACKING.....	14
3.2	PREPARATION FOR USE .....	14
3.3	PRE-OPERATIONAL SAFETY CHECK SCHEDULES .....	15
3.4	PLACARD, DECALS & INSTALLATION (UK SPEC) .....	17
3.5	TORQUE REQUIREMENTS.....	20
<b>4</b>	<b>Operation</b>	<b>21</b>
4.1	CONTROL CIRCUIT COMPONENTS .....	21
4.2	GROUND CONTROL OPERATION.....	23
4.3	PLATFORM CONTROL OPERATION .....	26
4.4	DRIVING CONTROLS.....	37
4.5	CAGE WEIGH SYSTEM.....	38
4.6	BATTERIES AND CHARGING .....	39
4.7	TRANSPORTING, TOWING, CRANEAGE, STORAGE AND SETTING TO WORK..	42
<b>5</b>	<b>Emergency Controls</b>	<b>47</b>
5.1	GENERAL .....	47
5.2	IN THE EVENT OF AN INCAPACITATED OPERATOR .....	47
5.3	IN THE EVENT OF MACHINE FAILURE .....	47
5.4	INCIDENT NOTIFICATION.....	47
<b>6</b>	<b>Responsibilities</b>	<b>48</b>
6.1	CHANGES IN OWNERSHIP .....	48
6.2	MANUAL OF RESPONSIBILITIES (USA only) .....	48
6.3	INSPECTION/SERVICE/PRE-HIRE CHECK LIST .....	49
	<b>Appendix A</b>	<b>52</b>
	<b>Appendix B</b>	<b>68</b>

# 1 Introduction and General Information

## 1.1 FOREWORD

The purpose of these manuals is to provide the customer with appropriate safety operating and maintenance instructions essential for proper machine operation.

All information in these manuals should be **READ** and fully **UNDERSTOOD** before any attempt is made to operate the machine. **THESE MANUALS ARE VERY IMPORTANT TOOLS** - Keep them with the machine at all times.

**The manufacturer has no direct control over machine application and use, therefore conformance with good safety practices is the responsibility of the user and his operating personnel.**

**All information in these manuals is based on the use of the machine under proper operating conditions. Alteration and/or modification of the machine are strictly forbidden.**

**One of the most important facts to remember is that any equipment is only as safe as those who operate it.**

### **DANGER, WARNING, CAUTION, IMPORTANT, INSTRUCTIONS AND NOTICE**

Any place these topics may appear, either in this manual or on the machine, they are defined as follows:

**DANGER:** If not correctly followed there is a high probability of serious injury or death to personnel.

**WARNING OR CAUTION:** If not correctly followed there is some possibility of serious injury or death to personnel.



THE '**SAFETY ALERT**' SYMBOL IS USED TO CALL ATTENTION TO POTENTIAL HAZARDS THAT MAY LEAD TO SERIOUS INJURY OR DEATH, IF IGNORED.

**IMPORTANT AND INSTRUCTIONS:** Denotes procedures essential to safe operation and prevention of damage to or destruction of the machine.

**NOTICE:** Indicates general safety rules and/or procedures relating to the machine.

**It is the owner's/user's responsibility to know and comply with all applicable rules, regulations, laws, codes and any other requirements applicable to the safe use of this equipment.**

## 1.2 SCOPE

These operating instructions contain all the necessary information required to allow the safe operation of any Niftylift Height Rider 28 (SP85 the USA) powered by diesel and DC electric.

For further technical information, circuit diagrams and specific instructions for all maintenance which may need to be carried out by specialist trained personnel, see the associated Workshop and Parts manual for your model of Niftylift Height Rider.

## 1.3 INTRODUCING THE HEIGHT RIDER SELF-PROPELLED (SP) SERIES

Please note at the time of going to press all information, illustrations, details and descriptions contained herein are valid. Niftylift reserves the right to change, modify or improve its products without any obligations to install them on previously manufactured machines.

If, after reading this manual you require further information, please do not hesitate to contact us.

**Niftylift Ltd, Chalkdell Drive, Shenley Wood, Milton Keynes MK5 6GF, Great Britain**  
**Tel: +44 (0) 1908 223456 Fax: +44 (0) 1908 312733**

**Niftylift Inc, 1525 S. Buncombe Road, Greer, SC 29651 USA**  
**Tel: +01 864 968 8881 Fax: +01 864 968 8836**

**Nifty Pty Ltd, 11 Kennington Drive, Tomago, NSW 2322, Australia**  
**Tel: +61 (0) 2 4964 9765 Fax: +61 (0) 2 4964 9714**

Driven from the platform, the Niftylift Height Rider 28 (SP85) is an extremely versatile articulated boom platform of unique and simple design. The HR28 can place two men and their tools at a height of 28.0m (91ft 10in) or an outreach of 18.9m (62ft).

The booms are mounted via a 360<sup>0</sup> powered swing mechanism onto a compact narrow base with a tight turning circle that ensures excellent manoeuvrability and maximum efficiency.

High traction tyres and powerful hydraulic wheel motors give unsurpassed performance with the option of fast drive speed when the booms are in the stowed position. Automatic braking and audible alarms activated by a tilt sensor help to prevent the operator from working on unsafe terrain whilst elevated.

A digital control system gives smooth, reliable movement of the platform and maximum reliability in the harshest environments.

*This Operating Manual is applicable to the following machines;*

Model	Power Source
HR28 Hybrid	Diesel & Battery

# **nifty** Height Rider/SP Series

## Operating & Safety Instructions

### 1.4 GENERAL SPECIFICATION

FEATURE	HR28 (SP85)
MAXIMUM HEIGHT - WORKING	28.00 m 91 ft 10 in
MAXIMUM HEIGHT - PLATFORM	26.00 m 85 ft 4 in
MAXIMUM OUTREACH	18.90 m 62 ft 0 in
MAXIMUM HEIGHT – STOWED	2.72 m 8 ft 11 in
MAXIMUM WIDTH	2.49 m 8 ft 2 in
MAXIMUM LENGTH – STOWED	9.3 m/7.3 m (cage tucked) 30 ft 5 in/23 ft 11 in
PLATFORM CAPACITY	280 kg 617 lbs
MAXIMUM PERSONS IN PLATFORM	3
WHEELBASE	2.60 m 8 ft 6 in
TURNING RADIUS – OUTSIDE	5.90 m 19 ft 4 in
TURRET ROTATION	Continuous
TURRET TAIL SWING	0.49 m 1ft 7 in
TRAVEL SPEED	0-4.5 km/h 0-2.8 mph
PLATFORM SIZE	2.40 m x 0.90 m 7 ft 10 in x 2 ft 11 in
CONTROLS	Digital
HYDRAULIC PRESSURE	207 bar (Booms) 315 bar (Drive)
TYRES	Foam filled
GRADE-ABILITY	45%
MINIMUM VEHICLE WEIGHT	14,633 kg 32,260 lbs
MAXIMUM GROUND PRESSURE	0.111 kN/cm <sup>2</sup> 23177 lbs/ft <sup>2</sup>
POINT LOAD	87.8 kN
POWER SOURCE	Hybrid - Kubota D1105 diesel engine, Schabmuller TSA200 electric motor and 12 x 6V 395 Ah AGM Batteries
SOUND POWER LEVEL	129dBA
SOUND PRESSURE LEVEL Base Controls	81dBA
SOUND PRESSURE LEVEL Cage Controls	71dBA

## 1.5 IDENTIFICATION (UK PLATE)

			
NIFTYLIFT LTD. RINGLE DRIVE, STONEBRIDGE MILTON KEYNES MK13 0ER ENGLAND TEL 01908 223456 : FAX 01908 312733 e-mail : info@niftylift.com			
SERIAL No			
TYPE			
YEAR OF MANUFACTURE			
WEIGHT			kg
RATED LOAD	PERSONS	+	kg
MAXIMUM SAFE WORKING LOAD			kg
MAXIMUM PULL			N
MAXIMUM WIND SPEED			m/s
MAX. ALLOWABLE INCLINATION			Deg.
MAXIMUM HYDRAULIC PRESSURE			bar
MAXIMUM VOLTAGE			V
AMPS			A
ELEC. CCT D	ISSUE		
HYD. CCT D	ISSUE		
			P10205

**This manufacturer's plate is attached to the chassis on each machine at the time of manufacture on every Niftylift. Please ensure all sections have been stamped and are legible.**

# **nifty** Height Rider/SP Series

## Operating & Safety Instructions

### 1.5a IDENTIFICATION (USA PLATE)

	
NIFTYLIFT LTD. RINGLE DRIVE, STONEBRIDGE MILTON KEYNES MK13 0ER GREAT BRITAIN TEL (01144) 1908 223456 : FAX (01144) 1908 312733 e-mail : info@niftylift.com	
THIS WORK PLATFORM COMPLIES WITH ANSI STANDARD A 92-	
MODEL	
SERIAL NO	
YEAR OF MANUFACTURE	
CAPACITY RATING	LBS
PLATFORM HEIGHT	FEET
GROSS WEIGHT	LBS
MAXIMUM HYDRAULIC PRESSURE	PSI
MAXIMUM VOLTAGE	V
AMPS	A
ELEC. CCT D	ISSUE
HYD. CCT D	ISSUE
P11497	

**This manufacturer's plate is attached to the chassis on each machine at the time of manufacture on every Niftylift. Please ensure all sections have been stamped and are legible.**

## 1.6 EC DECLARATION OF CONFORMITY (Typical)



### EC DECLARATION OF CONFORMITY

MANUFACTURER AND PERSON RESPONSIBLE FOR DOCUMENTATION:	NIFTYLIFT LTD *****
ADDRESS:	CHALKDELL DRIVE, SHENLEY WOOD, MILTON KEYNES, MK5 6GF, ENGLAND.
MACHINE TYPE:	MOBILE ELEVATING WORK PLATFORM
MODEL TYPE:	*****
SERIAL NUMBER:	*****
APPROVED BY:	NIFTYLIFT LTD CHALKDELL DRIVE, SHENLEY WOOD, MILTON KEYNES, MK5 6GF, ENGLAND
TECHNICAL FILE NUMBER:	*****
APPLICABLE STANDARDS:	BS EN 280:2013+A1:2015, BS EN 60204-1:2006+A1:2009 BS EN ISO 13849-1:2008

*We hereby declare that the above mentioned machine conforms with the requirements of the Machinery Directive, 2006/42/EC and EMC Directive 2014/30/EU.*

SIGNED:

DATE:

\*\*\*\*\*

NAME:

Steven Redding

POSITION:

Development Director

**NOTE:**

THIS DECLARATION CONFORMS WITH THE REQUIREMENTS OF ANNEX II-1.A OF THE COUNCIL DIRECTIVE 2006/42/EC ANY MODIFICATIONS TO THE ABOVE MENTIONED MACHINE WILL INVALIDATE THIS DECLARATION, AND THE MACHINE'S APPROVAL.

## **2 Safety**

### **2.1 MANDATORY PRECAUTIONS**

When operating the Niftylift, your safety is of utmost concern. In order to fully appreciate all aspects of the machine's operation it should be ensured that each operator has **READ** and fully **UNDERSTOOD** the relevant manual covering machine use, maintenance and servicing. If any doubts exist concerning any points covered in this manual, contact your local dealer or Niftylift Ltd.

Before using any Niftylift, thoroughly inspect the machine for damage or deformation to all major components. Likewise, check the control systems for hydraulic leaks, damaged hoses, cable faults or loose covers to electrical components. At no time should damaged or faulty equipment be used - Correct all defects before putting the platform to work. If in doubt, contact your local dealer or Niftylift Ltd (see front cover for address).



**THE MANUFACTURER HAS NO DIRECT CONTROL OVER THE MACHINE APPLICATION AND USE. THEREFORE CONFORMITY WITH GOOD SAFETY PRACTICES IS THE RESPONSIBILITY OF THE USER AND HIS OPERATING PERSONNEL. FAILURE TO UNDERSTAND AND FOLLOW ALL SAFETY RULES COULD RESULT IN SERIOUS INJURY OR DEATH.**

- 2.1.1** Only trained persons are permitted to operate the Niftylift.
- 2.1.2** Always operate the Niftylift in accordance with these model-specific Operating & Safety Instructions.
- 2.1.3** Before use each day and at the beginning of each shift the Niftylift shall be given a visual inspection and functional test including, but not limited to, operating and emergency controls, safety devices, personal protective clothing, including fall protection, air, hydraulic and fuel system leaks, cables and wiring harness, loose or missing parts, tyres and wheels, placards, warnings, control markings and Operating and Safety Manuals, guards and guard rail systems and all other items specified by the manufacturer.
- 2.1.4** Any problems or malfunctions that affect operational safety must be repaired prior to use of the platform, with specific regard to any safety components refer to the Parts Manual for part numbers and details. If in doubt, contact Niftylift Ltd (Details on page 3). **Ensure wheels are chocked before carrying out any maintenance that involves gearbox disengagement as described in Section 4.7.3**
- 2.1.5** Always ensure that all warning labels, instructions, placards, control markings and Operating & Safety Manuals are intact and clearly legible. If replacements are required contact your local dealer or Niftylift. **Always obey the safety and operating instructions on labels.**
- 2.1.6** Do not alter, modify, or disable in any way the controls, safety devices, interlocks, or any other part of the machine.
- 2.1.7** The user must ensure that, prior to and during use, the working area and transport route is free from possible hazards such as, but not limited to, uneven ground drop-offs, holes, bumps, obstructions, debris, floor and overhead obstructions, high voltage conductors, wind and weather, unauthorised persons and any other possibly hazardous conditions.

- 2.1.8** This machine contains several hazardous substances such as but not limited to: Battery acid, hydraulic Oil, grease and gear Oil.
- 2.1.9** Covers and canopies should remain closed when the machine is in operation. Only trained personnel should carry out maintenance on the machine, ensuring at all times they protect themselves from electrical, heat and mechanical hazards.
- 2.1.10** Never exceed the maximum platform capacity, as indicated on the decals and machine serial plate.
- 2.1.11** Only operate the Niftylift on a firm, level surface.
- 2.1.12** Never position any part of the Niftylift inside the **Minimum approach distances** (MAD) to above-ground electrical conductors as listed in the table below. (Reference ISO 18893:2014).

<b>Voltage range (kV)</b>	<b>MAD (m)</b>
<0.7	1
≥0.7 to 7	1.2
>7 to 50	3
>50 to 220	4
>220 to 500	5
>500 to 750	10
>750 to 1000	13
>1000 to 1250	16

**THIS MACHINE IS NOT INSULATED.**

If in doubt, contact the local appropriate governing authority.

- 2.1.13** On entering the platform ensure that the drop down entry bar is closed afterwards.
- 2.1.14** Use of an approved full-body harness and short lanyard, hard hat and appropriate safety clothing is mandatory. Fasten harness to designated harness securing points within the platform and do not remove until leaving the platform whilst in the stowed position. **Note**; if working next to or over water, the risk of injury from either falling or drowning must be assessed. Then the decision can be made if it is appropriate to wear a harness.
- 2.1.15**  Always remain standing within the platform. Do not attempt to increase your height or reach by standing and/or climbing on the platform guard rails or any other object. **KEEP YOUR FEET ON THE PLATFORM FLOOR.** Do not sit, stand or climb on the guard rail, mid rail or boom linkage. Use of planks, ladders or any other devices on the Niftylift for achieving additional height or reach shall be prohibited.
- 2.1.16** Do not use the platform levelling system to artificially increase the outreach of the platform. Never use boards or ladders in the platform to achieve the same result.
- 2.1.17** Do not use the platform to lift overhanging or bulky items that may exceed the maximum capacity or carry objects that may increase the wind loading on the platform. (e.g. Notice boards etc.)

# **nifty** Height Rider/SP Series

---

## **Operating & Safety Instructions**

- 2.1.18** The Niftylift shall not be operated from a position on trucks, trailers, railway cars, floating vessels, scaffolds or similar equipment unless the application is approved in writing by Niftylift Ltd in Great Britain.
- 2.1.19** Always check that the area below and around the platform is clear of personnel and obstructions before lowering or slewing. Care should be taken when slewing out into areas where there may be passing traffic. Use barriers to control traffic flow or prevent access to the machine.
- 2.1.20** Stunt driving and horseplay, on or around the Niftylift, is not permitted.
- 2.1.21** When other moving equipment or vehicles are present, special precautions shall be taken to comply with local ordinances or safety standards established for the work place. Warnings, such as but not limited to, flags, roped off areas, flashing lights and barricades shall be used.
- 2.1.22** Before and during driving while the platform is elevated, the operator shall maintain a clear view of the path of travel, maintain a safe distance from obstacles, debris, drop offs, holes, depressions, ramps and other hazards to ensure safe elevated travel. Maintain a safe distance from overhead obstacles.
- 2.1.23** The aerial platform is not equipped for or intended for use on a public highway.
- 2.1.24** Under all travel conditions the operator shall limit travel speed according to conditions of ground surface, congestion, visibility, slope, location of personnel and other factors causing hazards of collision or injury to personnel.
- 2.1.25** The aerial platform shall not be driven on grades, side slopes or ramps exceeding those for which the aerial platform is rated by the manufacturer.
- 2.1.26** It shall be the responsibility of the user to determine the hazard classification of any particular atmosphere or location. Aerial platforms operated in hazardous locations shall be approved and suitable for the duty. (See ANSI/NFPA 505 where applicable).
- 2.1.27** The operator shall immediately report to his supervisor any potentially hazardous location(s) (environment) which become evident during operation.
- 2.1.28** If an operator encounters any suspected malfunction of the Niftylift or any hazard or potentially unsafe condition relating to capacity, intended use or safe operation, they shall cease operation of the Niftylift and request further information as to safe operation from their management, or owner, dealer or manufacturer before further operation of the Niftylift.
- 2.1.29** The operator shall immediately report to their superior any problems or malfunctions of the Niftylift, which becomes evident during operation. Any problems or malfunctions that affect the safety of operation shall be repaired prior to continued use.
- 2.1.30** The boom and platform of the Niftylift shall not be used to jack the wheels off the ground.
- 2.1.31** The Niftylift shall not be used as a crane.
- 2.1.32** The Niftylift shall not be positioned against another object to steady the platform.
- 2.1.33** Care should be taken to prevent rope, electrical cords and hoses from becoming entangled in the aerial platform.
- 2.1.34** Batteries shall be recharged in a well-ventilated area free of flame, sparks or other hazards (e.g. do not smoke near the machine), which may cause explosion. Highly explosive hydrogen gas is produced during the charging process.

**2.1.35** If the platform or elevating assembly becomes caught, snagged or otherwise prevented from normal motion by adjacent structure or other obstacles, such that control reversal does not free the platform, all personnel shall be removed from the platform safely before attempts are made to free the platform using ground controls.

**2.1.36**



When the machine is not in use always stow the booms correctly. **NEVER LEAVE THE KEY IN THE MACHINE**, if it is to be left for any period of time. Use wheel chocks if leaving on an incline.

**2.1.37**

The engine must be shut down while fuel tanks are being filled. Fuelling must be done in a well-ventilated area free of flame, sparks or any other hazard that may cause fire or explosion. **PETROL (GASOLINE) AND DIESEL FUELS ARE FLAMMABLE.**

**2.1.38**



**NEVER START THE NIFTYLIFT IF YOU SMELL PETROL (GASOLINE), LIQUID PROPANE OR DIESEL FUEL. THESE FUELS ARE HIGHLY FLAMMABLE**

**2.1.39**

The operator must ensure that engine powered machines are used in a well-ventilated area to minimise the risk of carbon monoxide poisoning.

**2.1.40**

The operator shall implement means provided to protect against use by unauthorised persons.

**2.1.41**

Never remove anything that may affect the stability of the machine such as, but not limited to, batteries, covers, engines, tyres or ballast.

**2.1.42**

The operator must ensure that the controls are not obstructed (e.g. by tools or equipment) and **clear access to the Emergency Stop** is available at all times.

**2.1.43**

All persons in the cage must take suitable precautions to prevent items falling or being ejected from the cage. E.g. Tethering tools to the machine or operator if practical and an assessment of any resulting risks is acceptable.

**2.1.44**

Hydraulic oil escaping under pressure can penetrate the skin and cause **serious injury**. Do not allow hydraulic oil to squirt or spray. **Seek immediate medical attention in the event of hydraulic oil penetrating the skin.** Wear chemical-resistant protective gloves and suitable eye protection when handling hydraulic oil. Relieve system pressure before removing any hydraulic connections, undo fittings slowly to make sure there is no residual pressure. If pressure is detected, allow it to be released slowly before completely removing hose. Fluid leaks may not be visible to the naked eye. Use a piece of cardboard to check for leaks, not your hand. **Never** install hydraulic lines or components that are damaged.

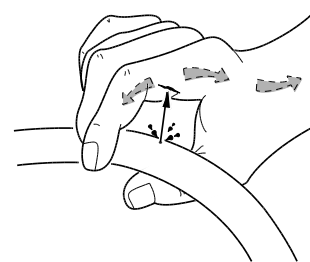

**2.1.45**

The HR28 MK2 has been tested in a UKAS accredited electromagnetic compatibility (EMC) chamber and complies with the relevant clauses of EN61326-3-1:2008, EN61000-6-2:2005 and EN55012:2007 for emissions and immunity. Niftylift offer a generator option on this machine, but cannot control the device that is connected to the system or the resulting variation in the amplitude of electrical noise produced when operating the generator. Niftylift therefore recommend that the generator is not used when the machine is located near any equipment that may be sensitive to electromagnetic disturbance.

**Operating & Safety Instructions**

**2.2 ENVIRONMENTAL LIMITATIONS**

Unless specifically configured otherwise, the machine will have a short operational time in extreme temperatures such as freezers and cold storage, due to reduced battery performance. For electrical cables and components, the temperature must be within the range -5°C to 60°C.

The machine is limited in high temperatures because of the cooling requirement for engines and hydraulic oil. Coolant temperatures must be within the range -37°C to 110°C (at 50% mixture of water to anti-freeze). Oil temperature must not exceed -23°C to 93°C.

**The recommended operational range for these machines is - 5°C to +30°C. Please contact Niftylift Ltd for special considerations if the machine is required to operate outside these temperatures.**

Extended operation in dusty environments is not recommended; frequent cleaning will be necessary. All dust, dirt, salt encrustation, excess oil or grease should be removed. Deposits of paint or bitumen, particularly on legends or labels should be removed.

All standard Niftylift machines are rated for a wind speed of 12.5 m/s, which equates to 45kph / 28mph or force 6 on the Beaufort scale. No attempt should be made to operate a Niftylift in wind strengths above this limit and if the operator has any doubts over the wind speed they should cease operation immediately until it can be established that the wind speed has fallen to a safe level.



**DO NOT USE THE NIFTYLIFT IN ELECTRICAL STORMS**

**2.3 NOISE AND VIBRATION**

The average A-weighted sound pressure levels measured at the operator control positions during normal machine operating conditions are shown in the table below:

<b>Operation mode and location</b>	<b>A-rated sound pressure level</b>
Booms from ground controls	81 dBA
Booms from cage controls	71 dBA
Drive from cage controls (Booms stowed)	78 dBA

In normal operation the vibration level to which the operator is subjected will not exceed a weighted root mean square acceleration value of 2.5 m/s<sup>2</sup>.

## 2.4 TEST REPORT

All Niftylift machine models are subjected to a comprehensive 'type test' which examines the worst-case combination of safe working load (SWL), overload, windage, inertia and pull force to assess the various safe stability criteria. Self-propelled machines are also subjected to kerb and braking tests at the SWL to satisfy additional dynamic stability requirements.

Each individual machine is then subjected to static overload tests on flat level ground with 150% of the SWL, exceeding the requirements of BS EN280:2013+A1:2015 for power operated MEWPs. Self-propelled machines are also tested at the maximum working angle **plus** 0.5° with a test load of 125% of the SWL. Finally, on all machines, a functional test is performed with 110% of SWL.

All safety devices are checked for correct operation, operating speeds are checked against benchmark figures and the dynamic functions ensure that all acceleration and deceleration forces are within acceptable limits. All noted defects are rectified and recorded before the machine is permitted to enter into service.

## **3 Preparation and Inspection**

### **3.1 UNPACKING**

Since the manufacturer has no direct control over the shipping or carriage of any Niftylift it is the responsibility of the dealer and/or owner and/or lessee to ensure the Niftylift has not been damaged in transit and a Pre-operational Report has been carried out by a qualified engineer before the aerial platform is put into service.

- 1) Remove all ropes, straps, and or chains used to secure the aerial platform during transit.
- 2) Ensure any ramp, loading dock or forklift used is capable of supporting or lifting the aerial platform.
- 3) If the aerial platform is to be driven off, please ensure that the operator has read and fully understood this entire manual. Refer to the appropriate section for precise operating instructions.

**\*\*Carry out the Pre-operational Report (Refer to Section 6.3) before placing machine in service.**

### **3.2 PREPARATION FOR USE**

Whilst every effort has been made at the Niftylift factory to ensure your machine arrives in a safe and operable condition it is necessary to carry out a systematic inspection prior to putting the aerial platform into service.



**THIS IS NOT A REQUEST IT IS MANDATORY**

To assist the user in this task you will find enclosed a Pre-operational Report, which must be filled out upon delivery/receipt of the machine.

Before the user carries out the Pre-operational Report he must have read and fully understood all the contents of the Operating, Safety and Maintenance Manual.



**WARNING - DO NOT OPERATE A POTENTIALLY DEFECTIVE OR MALFUNCTIONING MACHINE. CORRECT AND REPAIR ANY DEFECTS BEFORE OPERATING YOUR NIFTYLIFT.**



**MACHINE STABILITY** - The machine requires battery mass for stabilisation. If the batteries or any other significant component have been removed, **the machine will be unstable**. Contact Niftylift, UK before removal or replacement of any significant component.

### **3.3 PRE-OPERATIONAL SAFETY CHECK SCHEDULES**

Before use each day and at the beginning of each shift the aerial platform shall be given a visual inspection and functional test including, but not limited to, the following: It is recommended that these be performed at regular intervals as indicated on each checklist.

#### **3.3.1 DAILY SAFETY CHECKS**

- 1) Check that all labels (decals) are in place and legible.
- 2) Visually inspect the machine for damaged or loose components.
- 3) Check that batteries are charged (Refer to Section 4.6 for further information).  
**Note;** the diesel engine batteries are also used to power the emergency descent system.
- 4) Check the fuel level (if applicable).
- 5) Check that canopies/covers and guards are in place and secure.
- 6) Check that the boom rest switch is functioning correctly.
- 7) Check that control levers are secure and operate freely.
- 8) Check that operating buttons and emergency stop buttons function correctly.
- 9) Check the operation of the emergency descent pump.
- 10) Visually inspect all hydraulic hoses and fittings for damage or leaks.
- 11) Check that the platform pivot pins and their tag bolts are secure.
- 12) Check that the tilt alarm is functioning correctly (On a slope of 5 degrees or more the alarm should sound and drive should be disabled).
- 13) Check the operation of SiOPS (Refer to Section 4.3.6).
- 14) Check the operation of the cage weigh system.

#### **3.3.2 WEEKLY SAFETY CHECKS**

- 1) Inspect tyres and wheels for damage and wear.
- 2) Check that the joystick manipulators are secure.
- 3) Check hydraulic oil level, ISO Grade 32 (Standard or Bio).
- 4) Check engine coolant level. **Caution**, the cooling system is pressurised, so allow engine to cool sufficiently before removing filler cap.
- 5) Inspect the engine air filter and clean or replace if necessary.
- 6) Inspect hose track for damage or missing parts.

## **Operating & Safety Instructions**

### **3.3.3 MONTHLY SAFETY CHECKS**

- 1) Check the engine oil level (if applicable).
- 2) Check front wheel nuts are secured (torque 292ft lbs / 396Nm).
- 3) Check that the slew worm is secured and correctly in mesh. Clean and re-grease.
- 4) Check the track rod linkage.
- 5) Inspect brakes for operation and wear.
- 6) Inspect the engine fuel tank for damage or leaks.
- 7) Check telescopic boom wear pads and nylon studs (if applicable).

### **3.3.4 BI-ANNUAL SAFETY CHECKS**

- 1) Every six months of operation, the wire ropes inside the telescopic boom should be inspected in line with national or local regulations, for example LOLER (6 month thorough inspection in the UK) or IPAF guidelines. Refer to instructions in the Wire Rope Inspection Manual (**M50752**).  
Should any faults be found during inspection, information on repair and replacement can be found in the Wire Rope Inspection & Maintenance Manual (**M50490**).
- 2) Every six months perform a **thorough examination** in accordance with the 'Lifting Operation and Lifting Equipment Regulations' (LOLER) 1998, Regulation (9)(3)(a).

### **3.3.5 ANNUAL SAFETY CHECKS**

- 1) Check that all pivot pins and their tag bolts are secure.
- 2) Inspect for any cracks or badly rusted areas on booms and chassis.
- 3) Change the hydraulic oil filters.
- 4) Check that slew ring bolts are secure (torque 199ft lbs. 270Nm).

**3.4 PLACARD, DECALS & INSTALLATION (UK SPEC)**

ITEM	DESCRIPTION	NUMBER	QTY
1	Overload Warning	P18848	1
2	"If Tilt Alarm Sounds"	P14868	1
3	IPAF 'Are you trained?'	P22055	1
4	Clunk Click	P19961	1
5	"If E-Stop Disabled	P14864	2
6	'Do not place objects on controls'	P21511	1
7	'Fitted with SiOPS'	P22820	2
8	Cage Controls	P32532	1
9	General Warning	P24900	1
10	Operating Instructions	P14892	2
11	Raise flyboom	P19442	1
12	Footswitch	P14884	1
13	Harness Point	P32302	3
14	Cage Gate Warning	P18335	1
15	SWL 280kg	P24841	1
16	"Niftylift.com"	P14390	1
17	Cage tie-down warning	P21404	2
18	Point Loading - 87.8kN	P25068	4
19	Tie Down Points	P14958	4
20	Travel Direction	P29066	2
21	Battery isolator	P18600	1
22	Battery Drain	P19850	1
23	Joystick steer	P29068	1
24	Tank Pressure - Warning	P16365	1
25	Hydraulic Oil	P17226	1
	Low Temperature Bio Oil	P23622	1
26	4X4	P14697	2
27	Gearbox Disengage	P26280	2
28	Serial Plate - Blank	P32187	1
29	No Step	P14785	1
30	Diesel	P14414	1
31	Auxiliary recovery	P32217	1
32	Control Buttons - Base	P32444	1
33	Emergency controls location	P31872	1
34	Daily Safety Check List	P14908	1
35	Base Hydraulic Levers – Inside	P32681	1
36	Base Levers	P32680	1
37	'Green Machine' Large	P22804	1
38	Noise Warning dB	P17124	1

## **nifty** Height Rider/SP Series

---

### **Operating & Safety Instructions**

40	General crush hazard	P14782	8
48	Grip tape	N/A	N/A
49	Hazard tape	N/A	N/A
51	Wire Rope Inspection	P30580	1
52	Auxiliary key switch	P33216	1
53	Auxiliary	P32218	1
54	Cage levelling – Base	P32730	1
55	Power to cage - Generator	P28228	1
56	Power to cage - Universal	P24787	1
57	Power to cage - 230V	P26862	2
58	Power to cage - 110V	P26426	2
62	230V Charge Point	P26863	1
63	110V Charge point	P26424	1
64	Maintenance Free Batteries	P27750	2
65	'Nifty HR28 Hybrid'	P24781	1

# nifty Height Rider/SP Series

## Operating & Safety Instructions

### HR28 MK2 Series

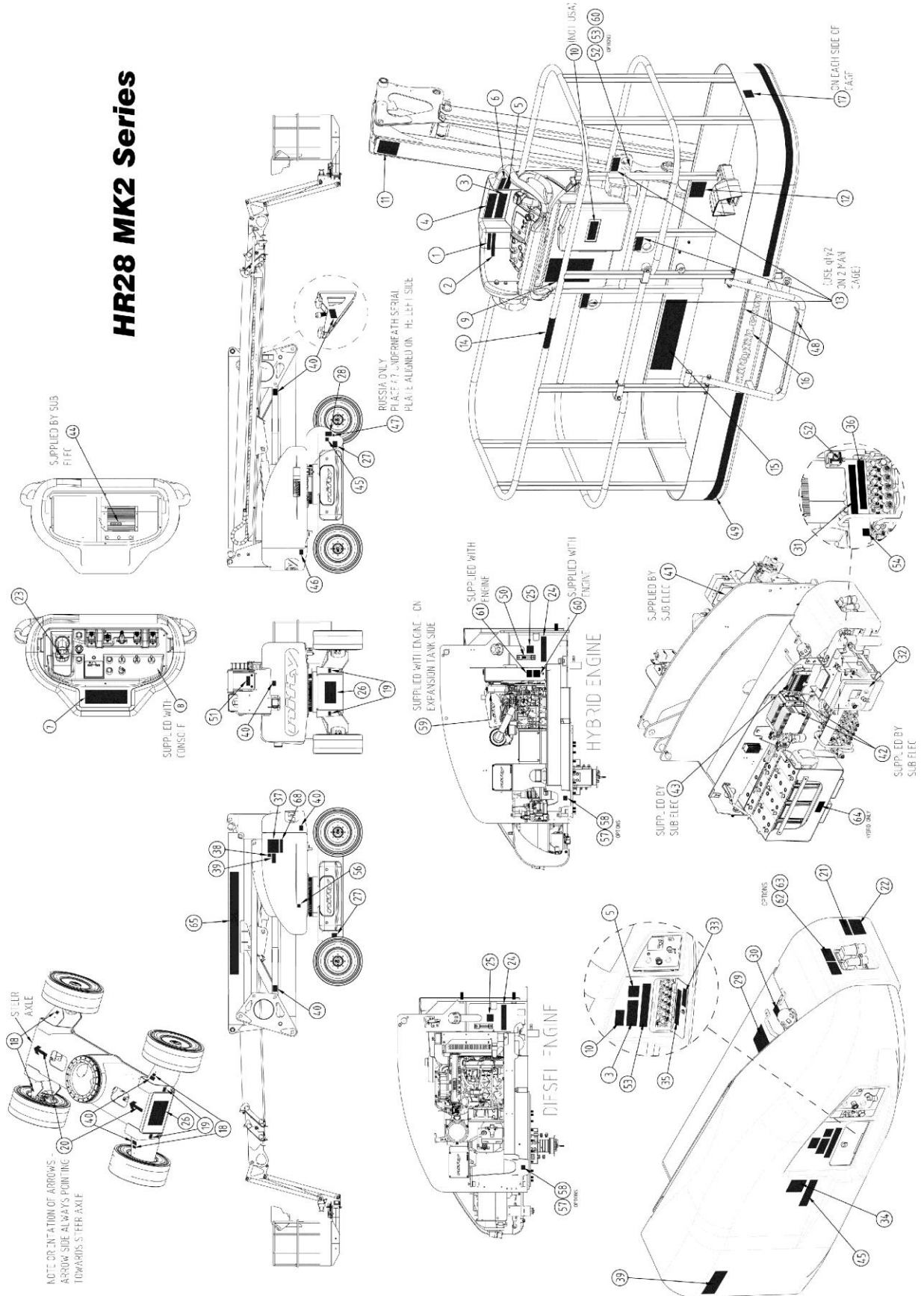

**Operating & Safety Instructions**

**3.5 TORQUE REQUIREMENTS**

BOLT QUALITY/SIZE	Tightening torque in lbs ft (Nm)					
	Plated			Unplated		
Grade	8.8	10.9	12.9	8.8	10.9	12.9
M 6	5 (7)	8 (10)	9 (12)	6 (8)	8 (11)	10 (13)
M 8	13 (17)	18 (25)	22 (29)	14 (19)	20 (27)	23 (32)
M 10	25 (34)	36 (49)	43 (58)	27 (37)	40 (54)	46 (63)
M 12	43 (58)	63 (85)	73 (99)	47 (63)	69 (93)	80 (108)
M 14	68 (93)	100 (135)	117 (158)	74 (101)	109 (148)	127 (172)
M 16	106 (143)	154 (209)	180 (245)	115 (156)	168 (228)	197 (267)
M 20	212 (288)	301 (408)	352 (477)	224 (304)	328 (445)	384 (521)
M24	362 (491)	515 (698)	602 (816)	383 (519)	561 (760)	656 (889)
WHEEL NUTS	292 ft lbs (396 Nm)					
WHEEL GEARBOX NUTS	99 ft lbs (135 Nm)					
SLEW RING BOLTS	199 ft lbs (270 Nm)					

This torque chart is based on the following assumptions:

- 1) Bolts to ISO 898-1 "Mechanical properties of fasteners made of carbon steel and alloy steel"
- 2) For "unplated" bolts, all grades:
  - Hex head bolts
  - Black oxide steel bolt with a rolled & oiled thread, no finish on steel nut
  - Prevailing torque includes Nylock (minimum prevailing torque figure assumed)
  - Medium Clearance holes to ISO 273
  - Bolt tightening condition = Yield factor of 75%
- 3) For "plated" bolts, all grades:
  - Hex head bolts
  - Zinc plated oiled (rolled or cut) steel external thread with no finish on steel internal thread
  - Prevailing torque includes Nylock (minimum prevailing torque figure assumed)
  - Medium Clearance holes to ISO 273
  - Bolt tightening condition = Yield factor of 75%

Figures quoted in **Nm** have been calculated in Nm and then rounded to the nearest whole number. Figures quoted in **lb-ft** have been calculated in Nm, converted using a factor of 0.737561 and then rounded.

## 4 Operation

### 4.1 CONTROL CIRCUIT COMPONENTS

#### 4.1.1 GROUND CONTROLS

**PROGRAMMABLE LOGIC CONTROLLER (PLC):** - Situated behind the Ground Controls Station is the PLC. Its purpose is to receive signals from **all** areas of the control, to process the instructions and machine status, and to safely operate the relevant machine functions.

Also, during machine operation, the Master PLC constantly receives signals from the Platform PLC (see Section 4.1.2) in order to monitor Safety Critical Functions. If for some reason any of these functions became inactive the Master PLC would immediately disable the machine.

**GROUND DISPLAY UNIT:** - Mounted in the Ground Control Station, this screen receives signals from the PLC to provide a warning indication to the operator for a range of functions. Refer to Section 4.3.2 for further details.

**TILT SENSOR:** - Installed on the superstructure behind the ground controls canopy, the tilt sensor monitors the inclination of the machine chassis. When the platform is in use, (i.e. Booms are raised), if the inclination exceeds the pre-set limit, it will disable all drive functions, sound the alarm and display a warning symbol on the screen. In order to recover the machine, boom operation is unaffected, allowing the operator to restore drive by lowering the booms into the stowed position. It is then possible to drive back onto level ground, fully restoring machine operation.

**MULTI-TONE SOUNDER AND BEACON:** - The Niftylift will warn personnel that the machine is about to move when the green power button or footswitch is pressed. The machine's default setting is to sound a beeper at the base control location and flash a beacon mounted on top of the counterweight. However, the machine can be configured to select either the sounder or the beacon if site conditions require the machine to behave differently. (e.g. Beacon only, when used at night in a residential area). It is mandatory that one alert device is functioning, and it is not possible to turn off or permitted to disable both the beacon and sounder.

If a **safety-critical** situation occurs (Refer to Section 4.3.3), the sounder will emit a "ricochet" sound to alert the user and nearby personnel. This warning occurs even if the motion sounder setting has been disabled.

**HORN:** - Located on the side of the ground control box is a horn, which is used as a manual alert, by pushing the "Horn" button on the Platform Control Panel.

**SLEW SWITCH:** - Mounted under the superstructure, this switch limits the drive speed to a preset low speed when the machine has been rotated from its stowed position.

**BOOM SWITCH:** - Mounted on the links knuckle and operated by the raising of link booms or upper boom, this switch controls both the operation of the Tilt Sensor, and the speed control function. With the booms in the stowed position, the Tilt Sensor is by-passed, allowing the machine to negotiate slopes in excess of the permissible elevated working angle, without isolating the drive function. At the same time, High Speed drive (Depicted by a Hare Icon) is possible. When the booms are raised the Tilt Sensor is activated and only Slow Speed drive is permitted. These control functions are of primary importance to safety of the machine and operator; **under no circumstances should this control function be isolated or by-passed.**

**Operating & Safety Instructions**

**TELESCOPIC BOOM SWITCH:** - Mounted inside the telescopic boom, this switch controls the operation of the Tilt Sensor and Speed Control function as described previously.

**4.1.2 PLATFORM**

**CAGE DISPLAY UNIT:** - Mounted in the Platform Control Station, this screen receives signals from the PLC to provide a warning indication to the operator for a range of functions. Refer to Section 4.3.2 for further details.

**LOAD SENSING CONSOLE (SIOPS™):** - This machine incorporates a load sensing console that senses if the operator has been pushed or has fallen against the console. If the load applied to the front of the console is greater than the pre-determined amount, the footswitch will be disabled to increase operator safety and reduce the possibility of sustained involuntary operation of the cage controls. For further information refer to Section 4.3.6.

**LOAD SENSING SYSTEM:** - This machine incorporates a load sensing system that senses if the load applied to the cage is greater than the pre-determined amount, an alarm will sound and a clear indication of visual overload will be given at each operating position. The system will not re-set until the overload has been removed in a safe manner. For further information refer to Section 4.5.

**4.1.3 FUSES**

**Power Tray**

- 35A** Circuit breaker inside ABS box
- 15A** Circuit breaker inside ABS box
- 10A** Circuit breaker inside ABS box

**Chassis**

- 3A** Circuit breaker inside box

**Ground Control Station**

- 2 x 225A** Fuse
- 1 x 125A** Fuse
- 3 x 15A** blade fuses inside Ground Control Box
- 2 x 10A** blade fuses inside Ground Control Box
- 3 x 5A** blade fuses inside Ground Control Box
- 2 x 2A** blade fuses inside Ground Control Box

**Platform Control Station**

- 2 x 2A** blade fuses behind Control Panel
- 2 x 15A** blade fuses behind Control Panel

## 4.2 GROUND CONTROL OPERATION

### 4.2.1 GROUND CONTROL FUNCTIONS

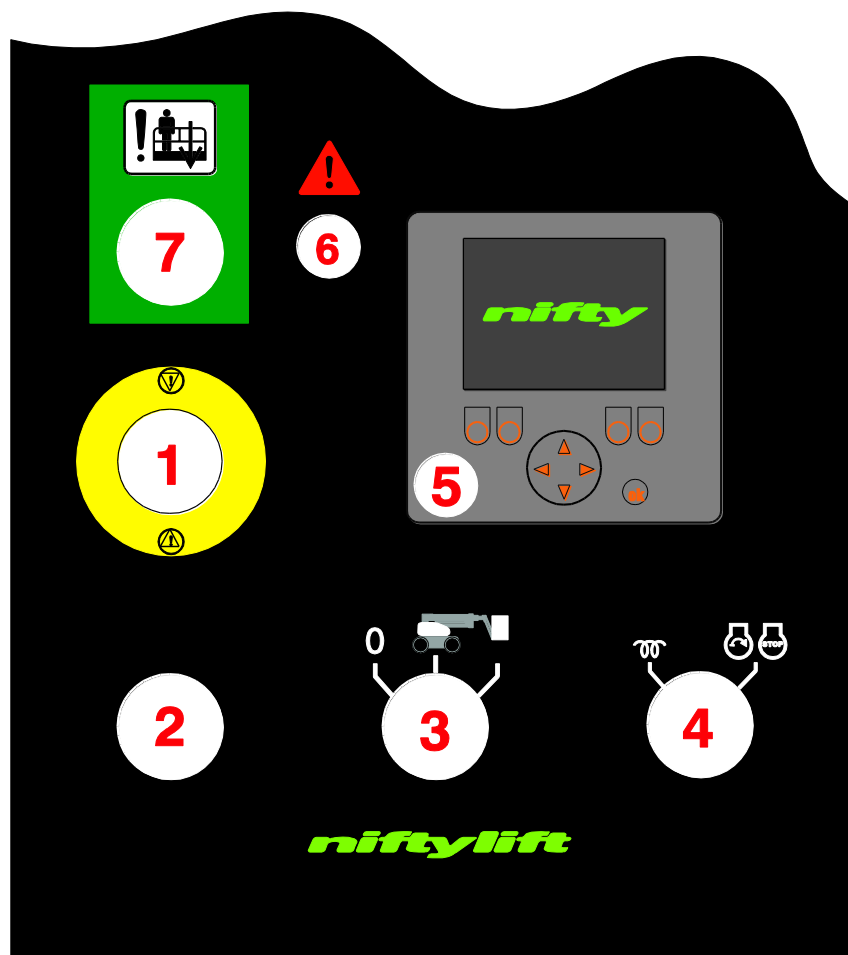

<b>1</b> Emergency Stop	Push to <b>Stop Operation</b>	Twist to <b>Enable Operation</b>
<b>2</b> Green Power Button	Push and hold for <b>Power</b>	Release to <b>Cease</b> operation
<b>3</b> Base/Platform Selector	<b>Clockwise</b> for Platform, <b>Centre</b> for Base, <b>0</b> for all power off	
<b>4</b> Engine Glow & Start/Stop	Anti-clockwise for <b>Glow</b> , Clockwise to <b>Start/Stop</b> engine	
<b>5</b> Display Screen	See Section 4.3.2	
<b>6</b> Status Lamp	<b>Red flashing:</b> Indicates safety critical problem. Refer to display screen <b>immediately</b>	
<b>7</b> White Override button	<b>Push</b> and hold to enable boom functions in the event of normal operation loss.	

**Operating & Safety Instructions**

**Base Levers**

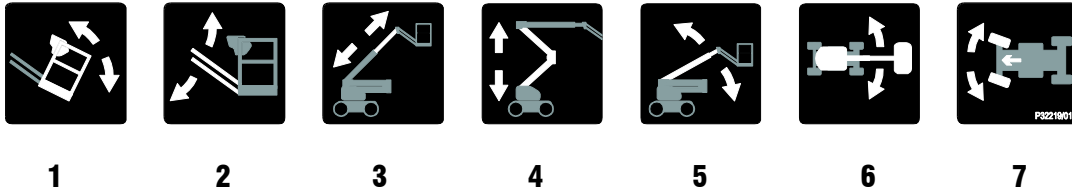

<b>1</b> Operates Platform Levelling	Forward for <b>Up</b>	Backward for <b>Down</b>
<b>2</b> Operates the Flyboom	Up for <b>Up</b>	Down for <b>Down</b>
<b>3</b> Operates Telescoping	Up for <b>Out</b>	Down for <b>In</b>
<b>4</b> Operates the Link Booms	Up for <b>Up</b>	Down for <b>Down</b>
<b>5</b> Operates the Upper Boom	Up for <b>Up</b>	Down for <b>Down</b>
<b>6</b> Operates Slew/Swing	Up for <b>Right</b>	Down for <b>Left</b>
<b>7</b> Operates Front Wheel Steer	Forward for <b>Right</b>	Backward for <b>Left</b>

**4.2.2 OPERATION**

**ALL MODELS**

- 1) Check below, above and around the platform for any obstruction or hazards before operating any function.
- 2) Ensure all red emergency stops are out.
- 3) Turn key switch at ground control station to **Ground** (Single turn clockwise).
- 4) For **Battery** powered operation, go to step 8).
- 5) For **Diesel** powered operation, go to step 6).

**HYBRID**

- 6) **COLD ENGINE:** - turn the **Diesel Glow/Start** selector to the **Glow** position (anti-clockwise). This engages the glow plug pre-heat system. Hold for 5-10 seconds then turn the key to the **Start** position (fully clockwise) and the engine will fire.
- 7) **WARM ENGINE:** - turn the **Diesel Glow/Start** selector to the **Start** position (clockwise) and the engine will fire.

**Note:** Unless the diesel engine is running, the HR28 Hybrid will automatically default to the electrical power source (battery).

### ALL MODELS

- 8) Push and hold green power button on the base control panel.
- 9) Select a function and operate the appropriate control lever in full accordance with the manufacturers operating and safety manual. (Refer to Section 4.2.1)
- 10) To return control to the platform, turn base control key-switch to the **Platform** position (fully clockwise).
- 11) When not in use return machine to stowed position. **Note:** Fully lower the Link booms first (Lever 4) followed by the Upper boom (Lever 5) for smooth operation. Turn the base control key-switch anti-clockwise to the **OFF** position, remove key and chock wheels.

### EMERGENCY PROCEDURES

- 1) **Push in** red emergency stop to shut down **all** machine movement.
- 2) **Release** both emergency stops to restore normal controls.

In the event that the controls fail, the cage overload is activated due to contact with a fixed object or a cage operator is incapacitated, the booms can be operated from the base location as described below:

*If normal controls are available (fastest recovery time):*

- 1) Turn key switch to **ground**, press the **green** button and operate the desired function lever(s).

*If cage overload is activated or main power source is depleted:*

- 2) Turn key switch to **ground**, press the **white** button and operate the desired function lever(s).
- 3) If recovering the machine because cage overload has deactivated the machine due to contact with a fixed object, then moving the machine slightly using step 2 should be sufficient to re-enable normal operation. The cage overload alarm and visual warning will cease once normal controls are available.
- 4) If normal controls are still not available, continue pressing the white button to lower the machine manually.

*If normal controls are **not** available (complete machine failure):*

- 5) Turn key switch to **0** and remove key
- 6) Open the control canopy and insert key into the Auxiliary descent key switch.
- 7) Turn key **clockwise** and **hold** in position.
- 8) Move and hold the desired boom function lever in the required direction.
- 9) Release the key or boom function lever to halt machine movement.

# nifty Height Rider/SP Series

## Operating & Safety Instructions

### 4.3 PLATFORM CONTROL OPERATION

#### 4.3.1 PLATFORM CONTROL FUNCTIONS

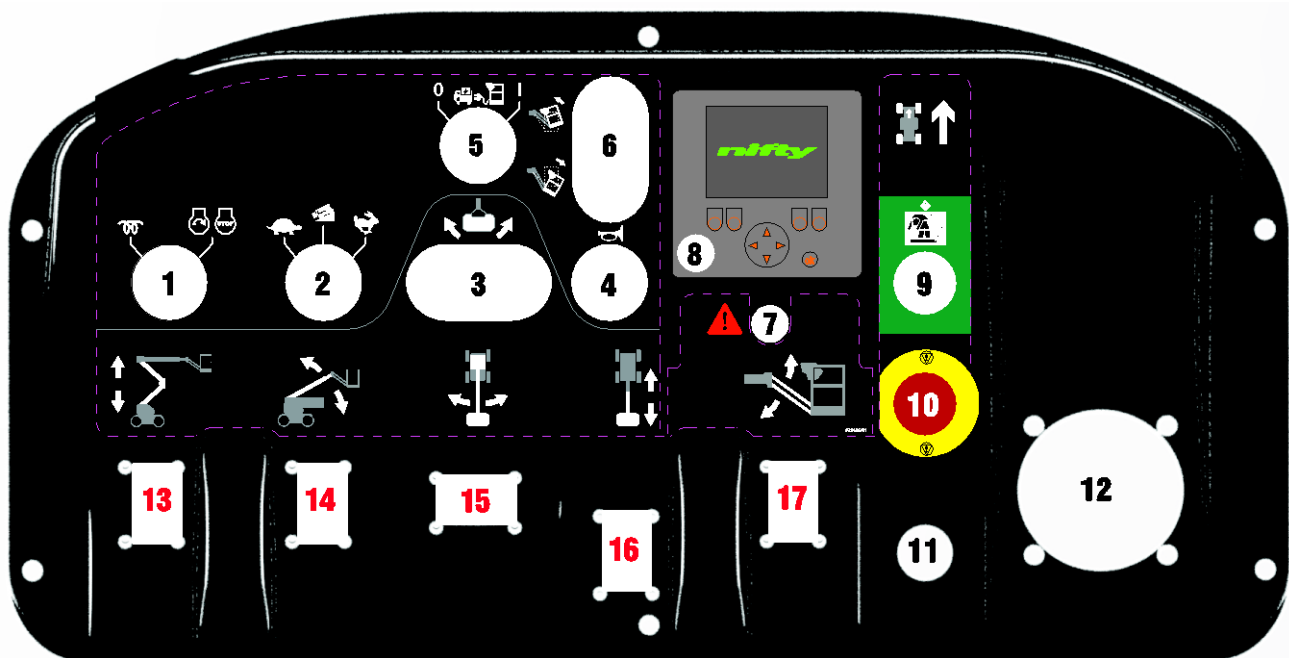

The platform controls are designed to prevent inadvertent operation of the machine and the user must be familiar with the following safety features.

- 1) **Footswitch timeout** – If the footswitch or green button is pressed, but no function is activated within 15 seconds, the machine will not function until the footswitch or green button is **released and re-pressed**.
- 2) **Controls neutral check** – If a boom control paddle or the drive joystick is moved from its neutral position **before** the green button or footswitch is pressed, that function will not be available until the control is returned to its neutral position and a deliberate action is taken to move the function **after** the green button or footswitch is pressed.
- 3) **Joystick Trigger timeout warning** – If the joystick trigger is pressed, but the machine is not driven within 10 seconds, then the machine will warn that the trigger has been held.

<b>1</b> Engine Glow/Start/Stop	Anti-clockwise hold for <b>Glow</b>	Clockwise to <b>Start/Stop</b> engine	
<b>2</b> Speed Selector	<b>Booms</b> <b>Drive</b>	<b>Left</b> - Speed I Tortoise	<b>Centre</b> - Speed II Off-road
			<b>Right</b> - Speed III Hare
<b>3</b> Platform rotation	RH arrow for <b>Anti-clockwise</b>	LH arrow for <b>Clockwise</b>	
<b>4</b> Horn	Press & hold to <b>Sound</b>		
<b>5</b> Generator Switch (option)	<b>Turn Clockwise</b> to activate generator		
<b>6</b> Platform levelling	Upper for <b>UP</b>	Lower for <b>Down</b>	
<b>7</b> Safety Warning Lamp	Indicates Safety Critical Problem (Refer to Digital Gauge <b>immediately</b> )		
<b>8</b> Display screen	See Section 4.3.2		
<b>9</b> Override button	<b>Push</b> and hold to enable boom functions in the event of normal operation loss. (i.e. fuel tank empty)		

<b>10</b> Emergency Stop	<b>Push</b> to Stop Operation	<b>Turn clockwise</b> to Release
<b>11</b> Green Power Button	<b>Push</b> and hold to activate machine	
<b>12</b> Joystick	Grip the joystick and hold the trigger switch at the front. Machine movement is achieved by slowly moving the joystick away from the neutral position in the required direction. Steer by using the thumb rocker switch located on top of the joystick.	
* <b>13</b> Operates Link Booms	Up for <b>Up</b>	Down for <b>Down</b>
* <b>14</b> Operates Upper Boom	Up for <b>Up</b>	Down for <b>Down</b>
* <b>15</b> Operates Swing	Left for <b>Left</b>	Right for <b>Right</b>
* <b>16</b> Operates Telescoping	Up for <b>Tele-In</b>	Down for <b>Tele-out</b>
* <b>17</b> Operates the Flyboom	Up for <b>Up</b>	Down for <b>Down</b>

\* **More than one function can be operated at the same time**

### 4.3.2 DISPLAY SCREEN

Situated on the Ground and Cage Control Panels, this gauge provides operational and/or a warning indication for a range of functions. For further information refer to Section 4.3.3 'Information Icons' on Page 28 or Section 4.3.4 'Menu Screens' on page 30. During machine operation the gauge displays current battery level, cage load status and current boom/drive speed setting.

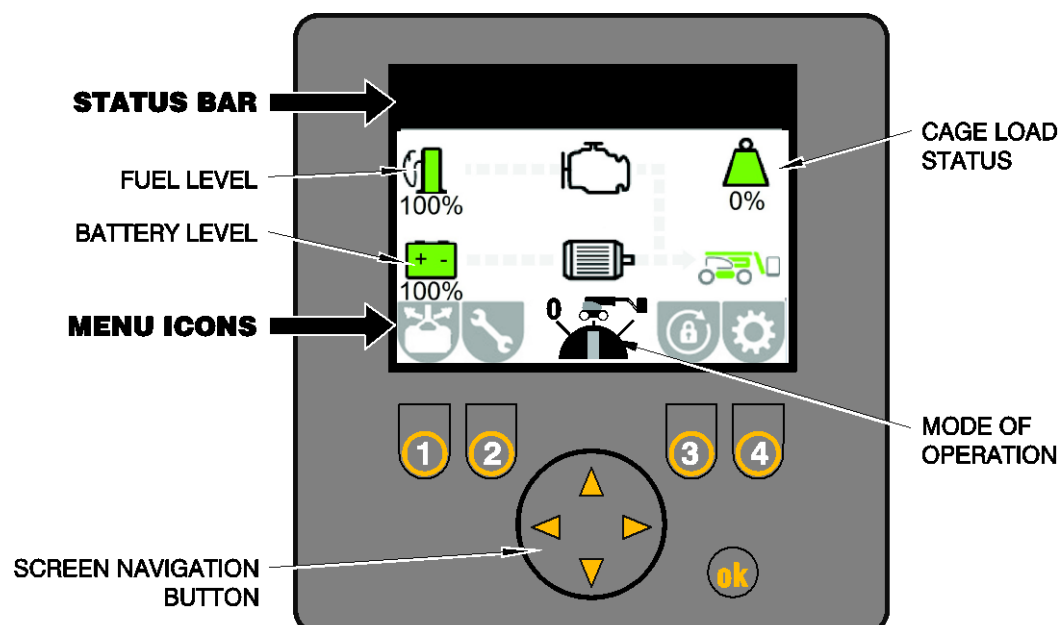

If the control system detects a malfunction on the machine one or more of the icons in the **status bar** will illuminate. Please refer to Section 4.3.3 for further info.

## Operating & Safety Instructions

### 4.3.3 INFORMATION ICONS

#### Safety Critical (Main screen)



**MAX tilt angle exceeded:-** The alarm sounds, the display shows this image and drive is disabled. Lower booms down into the stowed position and drive onto level ground to fully restore machine operation.



**Safe Working Load (SWL) exceeded:-** The alarm sounds and the display will show this image. The Maximum SWL (280kg/620lbs) has been exceeded. Immediately remove any unnecessary items from the platform **in a safe manner** to restore machine functions.

Alternatively, the platform may have come into contact with a fixed object, see Section 4.3.5 for recovery procedure.



**MAX cage level angle (10°) exceeded:-** The alarm sounds, the display shows this image and all machine functions cease. Use the platform levelling button (Refer to Section 4.2.1, Item 6) in conjunction with the white button to reduce this angle, therefore restoring machine functions.

Note: If a **Safety Critical** condition has been detected, the safety warning lamp on the Platform Control Panel and Base Control Panel will also illuminate.

#### Advisory (Main screen)



**Release E-Stop:-** Machine will not operate as one or both of the Emergency Stop buttons are pressed. Twist and release to restore normal controls.



**Footswitch Timeout:-** Machine will not operate. Release and re-press footswitch or green button to restore normal controls (Refer to Section 4.3.1).

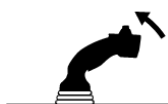

**Controls Neutral:-** Boom control paddle or drive joystick has moved from the neutral position **before** the green button or footswitch was pressed. Return to neutral position and move **after** green button or footswitch has been pressed (Refer to Section 4.3.1).



**Joystick Timeout:-** Machine drive will not operate. Release and re-press trigger to restore normal controls (Refer to Section 4.3.1).

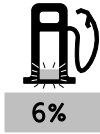

**Fuel Level Low:** Flashing fuel pump icon indicates fuel tank is <10% full. Amber level indicates fuel tank is <30% full.



**SiOPS:-** SiOPS has been activated, to restore normal machine controls refer to Section 4.3.6.



**Cage Level:-** The cage angle has exceeded 5°, use the platform levelling button (Refer to Section 4.3.1, Item 5) in conjunction with the green button or footswitch to reduce this angle, therefore restoring boom and drive functions.

**Advisory (Mode of operation)**



**Drive/Function Speed:** Determined by the Speed Selector switch on the Platform Control Panel (Refer to Page 26). Digital display reverts to these icons once the joystick trigger is activated.

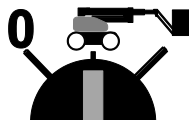

**Ground Controls:** To enable **platform** controls, selector switch located on ground controls must be turned clockwise (Refer to Section 4.2.1, Item 3).



**Override:** Override button is in use. (Refer to Section 4.2.1, Item 9)



**Drive Disabled:** Drive function has been disabled due to a safety critical condition. To restore drive, refer to Safety Critical Section on Page 28.

**Status Bar**

If icons on the status bar are 'greyed out' this indicates normal operation.



**Engine**

**Amber:** Low oil pressure or high water temperature.

**Red:** Engine malfunction.  
 (May illuminate in conjunction with the General Error icon)

Press **Button 2** for further information.



**Operating & Safety Instructions**



**Electric Motor**

**Amber:** Warning, motor on reduced power.

**Red:** Communication Error detected.

Press **Button 2** for further information.



**Tilt Warning**

**Red:** Max tilt angle exceeded.

(Refer to 'Safety Critical (Main screen)' section on page 28).



**Cage Overload Warning**

**Red:** SWL exceeded.

(Refer to 'Safety Critical (Main screen)' section on page 28).



**Cage Overload/Levelling Override Evidence**

**Amber:** Cage overload/levelling has been overridden. This will remain until reset.



In order to reset overload override evidence, press **Button 3** and follow on-screen instructions.



**General Error**

**Amber:** General error.

**Red:** Critical error.

Press **Button 2** for further information.



**4.3.4 MENU SCREENS**



**DIAGNOSTICS**



To access this screen, press button **2**.

This displays options to access **Error Codes, Software Version, Hour Counters, Machine Info, Joystick Position, Paddle Position, Base Inputs, Cage Inputs, Outputs** and **Safety Switches** information.

Scroll up or down to the information required using the arrow keys and press **ok** to open the screen. Press Left arrow key or button **1** to return to previous screen.

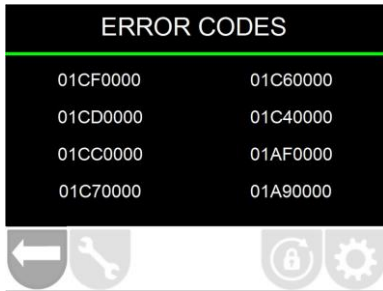

**Error Codes**

If the control system detects a malfunction on the machine, an error code will be displayed. For further information refer to **Appendix A**, or the HR28 MK2 Service Manual.



**Software Version**

Displays a list of the programmable devices installed on the machine and the software version for each device.

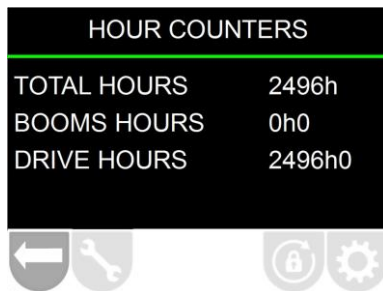

**Machine Hours**

Total Hours, Booms Hours and Drive Hours are displayed.

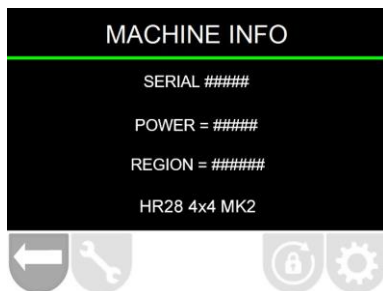

**Machine Info**

This displays information specific to the individual machine.

Serial Number, Power Type, Region and Model.

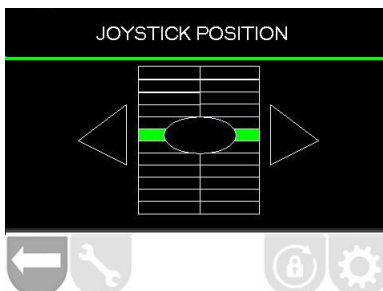

**Joystick Position**

The screen displays signal function whilst operating the Joystick. The coloured squares on the screen should move in relation to the movement of the joystick.

## Operating & Safety Instructions

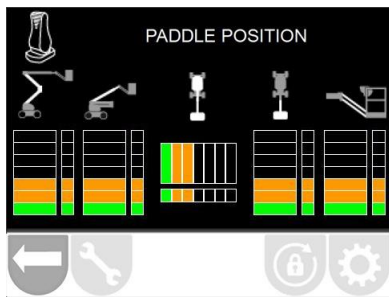

### Paddle position

The screen displays signal function whilst operating any cage control paddle. The coloured squares on the screen should move in the same direction as the paddle.

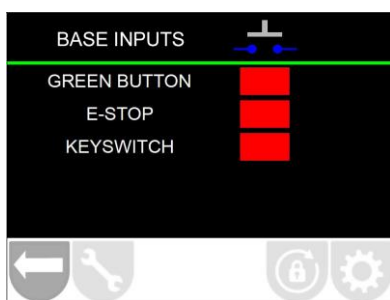

### Base Inputs

The screen displays current status of functions on the Base Control station.

Grey = Not activated

Green = Activated

Red = Error (Check error code display).

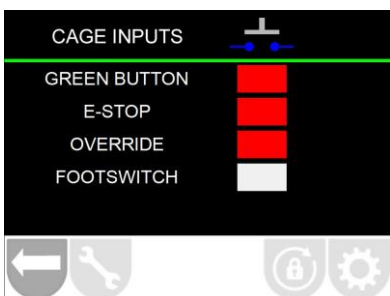

### Cage Inputs

The screen displays current status of functions on the Cage Control station.

Grey = Not activated

Green = Activated

Red = Error (Check error code display).

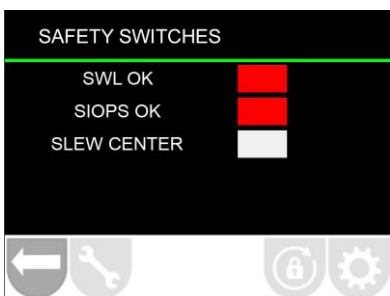

### Safety Switches

The screen displays current status of safety sensor inputs.

Grey = Not activated

Green = Activated

Red = Error (Check error code display).

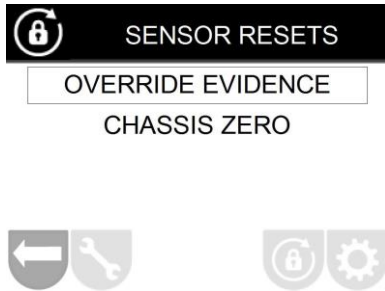

**SENSOR RESETS**



To access this screen, press button **3**.

To reset either the Cage overload override evidence or Chassis zero, contact Niftylift using the details displayed and quote the reference number displayed on the screen.

Niftylift will supply a code which must be entered by using the arrow keys.

**Note:** The machine **must** be in the stowed position when entering the code.

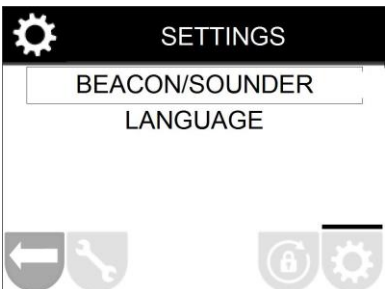

**SETTINGS**



To access this screen, press button **4**.

Beacon/Sounder and Language options are displayed.

Scroll up or down to the information required using the arrow keys and Press **ok** to open the screen. Press Left arrow key or button **1** to return to previous screen.

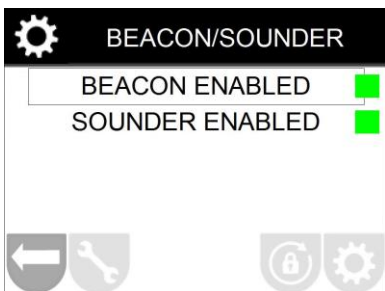

**Beacon/Sounder**

This allows the operator to select between the beacon or sounder for a motion alert.

Note: Either the Beacon or Sounder **MUST** be enabled; the system will automatically select one if the operator attempts to deselect both.



### Language

This allows the operator to choose a language for the menu screens.

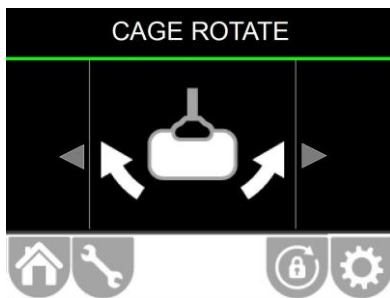

### Cage Rotate (Ground Controls Only)

To access this screen, press button **1**.

This allows the operator to rotate the cage from the Ground Controls.

Push and hold green power button on the ground control panel. Press either the left or right arrow on the navigation button (Refer to Section 4.3.2) as required. The on screen direction arrow will revert to **orange**.

#### 4.3.5 OPERATION



**BEFORE OPERATING THE NIFTYLIFT ENSURE THAT EACH OPERATOR HAS READ AND FULLY UNDERSTOOD THE OPERATING MANUAL. FAILURE TO DO SO MAY RESULT IN DEATH OR SERIOUS INJURY.**

##### ALL MODELS

- 1) **NEVER** exceed the maximum platform capacity.
- 2) Check below, above and around the platform for any obstruction or hazards before operating any function.
- 3) Ensure all red emergency stops are out.
- 4) Turn key switch at ground control station to **Platform** (fully clockwise).
- 5) Depress the footswitch or push and hold green power button on the platform control panel.
- 6) Select one or more functions and operate the appropriate proportional paddles (levers) in full accordance with manufacturers operating and safety manual.
- 7) To return control to the base, turn the base control key-switch to the **Base** position (centre).
- 8) When not in use return booms to the stowed position. Turn key switch on the ground control station to the fully anti-clockwise **OFF** position, remove key and chock wheels.



**ALWAYS ENSURE THE AERIAL PLATFORM IS ON A FIRM LEVEL SURFACE AND THE AREA IS FREE OF ANY OVERHEAD OBSTRUCTIONS.**

**ENGAGING THE RED EMERGENCY STOP BUTTON WILL SHUT DOWN THE ELECTRIC CIRCUIT, PREVENTING OPERATION OF ANY FUNCTION.**

##### EMERGENCY PROCEDURES

- 1) Push in red emergency stop to shut down **all** machine movement.
- 2) **Release** both emergency stops to restore normal controls.

In the event that the controls fail or the cage overload is activated as described in Section 5.3, the booms can be operated from the cage location as described below:

- 1) Press **white override button** situated on the cage console. (Refer to Section 4.3.1)
- 2) Activate a single desired function paddle.  
(Note: Multiple boom function is not available in override mode).
- 3) If the cage has contacted a fixed object and cage overload has disabled the machine, move machine slightly using steps 1-2. The overload alarm and visual warning will cease and normal controls are available.
- 4) Use normal controls if available for the fastest recovery time. Press the green button or footswitch and operate the desired function lever(s).

### **Operating & Safety Instructions**

- 5) If normal controls are not available, continue using the override button to lower the machine using auxiliary power.

**Note:** The override mode is for **booms only** and will not operate the drive function.

#### **4.3.6 SiOPS™ - LOAD SENSING CONSOLE**



**WHEN OPERATING THIS MACHINE THE USER MUST BE AWARE OF ANY OVERHEAD OBSTRUCTIONS.**

This machine incorporates a load sensing cage console that senses if the operator has been pushed or has fallen against the console. If the load applied to the front of the console is greater than the pre-determined amount, the footswitch will be disabled to increase operator safety and reduce the possibility of sustained involuntary operation of the cage controls.

**Note:** The green button will illuminate once the footswitch has been disabled, but continues to be available for use at all times. This allows the operator to use the cage control functions and manoeuvre the machine to a safe position. If cage overload has also activated, the procedure described in Section 4.3.5, 'Emergency Procedures' (above) should be followed first.

To reset the footswitch and normal controls:

- 1) Release the load from the front of the console.
- 2) Ensure cage controls are in the neutral position and clear of objects
- 3) Raise foot clear of footswitch then lower foot onto footswitch to reactivate.

**Note:** If SiOPS™ has been activated and the footswitch is not reset within **15 seconds**, then the blue warning beacon will flash (located on underside of the cage) and a warning announcement will sound until the footswitch is reset as described previously.

## 4.4 DRIVING CONTROLS



**DO NOT OPERATE THE NIFTYLIFT WHILST ELEVATED UNLESS ON A FIRM, LEVEL SURFACE FREE FROM ANY POSSIBLE OBSTRUCTIONS OR HAZARDS BOTH AT GROUND LEVEL AND OVERHEAD.**

- 1) Check proposed route for possible hazards, obstructions and personnel.
- 2) Depress footswitch located on platform floor.
- 3) Set the **speed selector** switch on the platform control station as required.

**Low Drive** (Tortoise) - gives low speed and low engine revs.

**High Drive** (Hare) - gives high speed and high engine revs.

**Off-road** (High Gradeability) - gives low speed, high engine revs and high gradeability.

Note; **High Drive** Speed is only available when the booms are stowed and in **alignment** with the chassis i.e. at 0° or 180° rotation. **The HR28 will default to Low Drive speed whenever the booms are elevated.**

If the machine is driven on slopes exceeding 10° it automatically reverts to **Off-road** speed (High Gradeability). To return the machine to Low or High Drive, drive on to level ground (<10°) then release and reactivate the joystick or footswitch.

- 4) Select drive joystick from the platform control panel.

Push forward for **FORWARD DRIVE**

Pull backwards for **REVERSE DRIVE**

Steering is controlled by the rocker-switch button on the top of the joystick

Left for **STEER LEFT**

Right for **STEER RIGHT**

The driving horn is activated by a button on the platform controls (Refer to Section 4.3.1).

All control levers give a fully proportional response therefore the more the lever is moved away from the centre **off** position the faster the function will become.

When driving with the booms fully stowed, the Tilt Sensor is bypassed to allow the Niftylift to be driven in areas where the slope exceeds the allowable inclination limit. In normal operation the drive is therefore unaffected when driven onto a slope in excess of this limit, until the booms are raised, whereupon the drive is disabled and the tilt alarm sounds continuously.



**ALL MACHINES HAVE A TILT ALARM INSTALLED - PRE-SET IN THE FACTORY. ONCE ENERGISED, THE MACHINE WILL LOSE ALL POWER TO DRIVE FUNCTIONS AND A LOUD AUDIBLE ALARM WILL BE ACTIVATED.**

**TO DE-ACTIVATE, LOWER THE BOOMS FULLY TO THEIR STOWED POSITION AND RE-POSITION BASE ON FIRM, LEVEL GROUND.**

**IF ALARM SOUNDS - DESCEND IMMEDIATELY AND RE-LEVEL MACHINE BASE.**

## Operating & Safety Instructions

### 4.5 CAGE WEIGH SYSTEM

#### 4.5.1 LOAD CELL VERSION

The Niftylift HR28 is fitted with an electronic load cell. This load cell is a moment-independent design. This means that independent of the load position inside the machine cage, the actual load is measured and if pre-calibrated limit values are exceeded, warnings will be activated. If load exceeds the safe working limit (SWL) of the machine, the machine will be disabled until the load is reduced to below 95% of the safe working limit. The design of the unit meets the requirements of both BS EN 280 and ISO 13849 with a safety integrity level of "Category 3 PL d. (Refer to Appendix B)

The current load in the cage is displayed on the digital display unit as a percentage of SWL. Please refer to Section 4.3.2.

#### 4.5.2 CALIBRATION, INSPECTION AND MAINTENANCE

Calibration, maintenance and repair of the Niftylift HR28 cage load cell requires specialist knowledge and equipment. **For this reason, no part of the Niftylift HR28 cage-weigh system can be adjusted, repaired or inspected by the operator.**

All enquiries relating to calibration, inspection or maintenance should be directed to Niftylift or one of their approved dealers. Contact details are listed in Section 1.3.

## 4.6 BATTERIES AND CHARGING

- 1) Recharge batteries at the end of every working day or shift.  
(**Note:** To recharge batteries fully from 20% charged takes approx. 12 Hours, this consists of 8 hours bulk charging plus 4 hours equalisation. The recharging time can be reduced to approx 4-6 hours by running the engine whilst charging).
- 2) Plug charger into suitable power supply, either 240 volts or 110 volts AC (see **Charging Limitations**). (Note: If using 240V, use of a suitably rated Earth Leakage Circuit Breaker (ELCB) or Residual Current Device (RCD) at the point of supply is highly recommended.) The charger will conduct a self-test at this point indicated by flashing all lamps in sequence.
- 3) Take note of the indicators provided:  
**Amber AC lamp:** *Static* - Batteries are charging.  
*Flashing* – Low AC voltage. Check source.  
**Amber CHARGE lamp:** *Static* - Batteries are charging and between 80% & 100% capacity.  
**Green FINISH lamp:** *Static* - the batteries are fully charged.  
*Flashing* – Finishing phase.  
**Red lamp flashing:** Fault (see 'Charging Limitations').
- 4) The charger will automatically switch off once the batteries are fully charged. It is recommended to reconnect the charger to a suitable power supply when the machine is not in use to maintain good battery condition. Charger will monitor and maintain correct battery charge level.

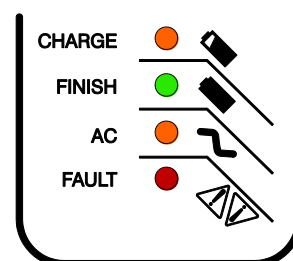

**UNDER NO CIRCUMSTANCES SHOULD A MACHINE BE LEFT FULLY DISCHARGED AS SEVERE BATTERY DAMAGE CAN OCCUR IN A RELATIVELY SHORT TIME.**

- 5) The machine boom functions can be used whilst on charge. **Do not drive** machine to avoid damage to cables etc. To disconnect charger, firstly switch off the power supply. Ensure LED's are **off** before disconnecting the charger from the power supply.

### Notes:

- 1) If the charger is reconnected to the power supply shortly after it has gone through its full charging cycle, the charger will show the Amber AC lamp, immediately followed by the Amber Charge lamp. The charger would then go through its complete cycle again at an accelerated rate, depending on the time difference between connection, reconnection, and level of battery charge.
- 2) Some machines are fitted with a Battery Management System, which permanently monitors the condition of the batteries. When the batteries become discharged to 20% of their capacity the management system will begin to "shut down" the hydraulic power packs. This causes the drive/boom operating system to alternately stop and start, signalling to the operator that recharging is necessary. However, there is sufficient power remaining to enable the operator to drive slowly to the nearest charging point.

**Operating & Safety Instructions**

- 3) During normal machine usage with the engine running, the batteries are on continuous recharge, except when the control system decides that additional electric power is required in order to maintain drive/function speed.
- 4) The machine has two charging units (Master and Slave). Both units will activate initially, the Slave unit will switch off at approximately 80% capacity then the Master unit will complete the charging cycle.

Should the operator ignore the onset of the battery discharge warning the "shut down" of the motors will continue, until the machine is rendered in-operative. **Immediate charging will then be required.**

**CHARGING LIMITATIONS**

The capacity of the 110V supply must be capable of 3.5kVA (32A current); hence a small hand-tool transformer must **not** be used with the battery charger.

**Note;** charger output will fall if air temperature is below 0°C or above 50°C.

The charger may become hot during charging. Use hand protection to safely handle the charger.

**Fault Conditions**

If a fault occurs, count number of flashes between pauses and refer to table:

Red LED status	Cause	Solution
<b>One</b> flash	Battery High Voltage	Check battery size and condition. This fault will automatically clear once the condition has been corrected.
<b>Two</b> flashes	Battery Low Voltage	Check battery size and condition. This fault will automatically clear once the condition has been corrected.
<b>Three</b> flashes	Charger Timeout. Caused by battery pack not reaching required voltage.  Charger output reduced due to high ambient temperature.	Check connections.  Operate charger at a lower ambient temperature.  Reset charger (interrupt AC power for 15 seconds)
<b>Four</b> flashes	Check Battery(ies); battery could not be trickle charged up to minimum voltage.	Check for shorted or damaged cells  Reset charger (interrupt AC power for 15 seconds)
<b>Five</b> flashes	High temperature. Charger shut down due to high internal temperature.	Ensure sufficient cooling airflow and reset charger (interrupt AC power for 15 seconds)
<b>Six</b> flashes	Charger Internal Fault	Reset charger (interrupt AC power for 15 seconds). Return to service department if fault persists.

Attention should also be given to the use of extension cables as power leads. **Excessive cable lengths** from the supply point to the battery charger will result in **significant voltage drop**, leading to a reduction in the chargers efficiency. In addition, inadequate sized cable cores will have a limiting effect on its current carrying capacity, which will again lead to a reduction in the chargers efficiency. Both of these can result in **over-heating** of the cable with an increased risk of fire, short circuits, or damage to the components themselves.

The charger requires a minimum battery voltage of 1.5 volts per battery (overall for two batteries 3 volts, for 4 batteries 6 volts for 8 batteries 12 volts and 18V for 72V). If the voltage is below these values then the charger will not function (Charger will not detect batteries to begin charge.) If the batteries have fallen to such a poor state they will have to be removed from the machine and charged individually with an independent charger until the optimum voltage has been reached. This is best performed at very low currents to 'recover' the batteries if sulphation has already started i.e. a 'trickle' charger. This can take several hours, possibly days. Careful monitoring of the rise of battery voltage will indicate when recovery has been achieved.

#### **TOPPING UP**

The batteries installed on this machine are Maintenance Free. **DO NOT ATTEMPT TO REFILL** or irreparable damage will occur.

## **Operating & Safety Instructions**

### **4.7 TRANSPORTING, TOWING, CRANEAGE, STORAGE AND SETTING TO WORK**

#### **4.7.1 TRANSPORTING**

If a work platform is to be moved over a longer distance, whether the machine is trailer mounted, vehicle mounted, self-propelled or tracked, the following procedure should be read before restraints are attached to the machine. Cross loading is most frequently the cause of problems, as the method of loading is no longer in sight of our own personnel. The recommendations made herein should be passed on to subsequent carriers, such that the entire journey is carried out without incident.

- Always ensure the truck or trailer you are loading or towing the Niftylift with can carry it legally.
- If loading by crane the use of shackles and an adequately rated spreader beam, with four leg slings, is **MANDATORY**.
- When loading or un-loading from the side of the vehicle, the use of the forklift pockets to retain one of the forks is recommended. (If fitted). Spread the forks to their widest capacity, with due regard to the components fitted to the machine. Never forklift or crane an entire machine under the booms, always lift beneath the spine or under the ends of the axle mountings in the case of a self-propelled unit. Ensure forklift is adequately rated for the load to be carried.
- Once positioned on the transport carrier ratchet straps should be used to secure the machine. The machine should be positioned to allow easy access around the machine in transit, and to ensure that 'creepage' during transport does not permit the machine to come into contact with other goods being shipped, or the container itself. Some movement of the machine structure might occur during transit, which could lead to fretting or other damage.
- If the machine is equipped with a transit device such as a boom clamp etc, this should be securely applied.
- Strap booms carefully to constrain them from sideways movement. When using straps or chains, adequate packing should be applied to stop any damage to the structure and paintwork. Due regard of the movement of the straps or chains must be taken into account.
- Where a machine has designated points for strapping, lifting or forking, these can be used for tie-down duty. When they are absent, the major structure of the platform can be used, giving due consideration to the design and function of the area chosen. Where possible, use the spine of the machine or axle mounts over which to apply the holding down forces. Using a single plate, such as an outrigger or stabiliser support plate might be unsuitable. Only apply transport straps to the marked anchor points on the machine.
- Under no circumstances should straps or chains be applied over booms or through the cage support structure or the cage itself. The relative strength of the carrying structure is not conducive to the massive forces capable of being applied through ratchet chains or slings. Severe damage to the steelwork can be caused, as well as deformation to sensitive mechanisms such as cage weigh assemblies, which would render them useless. Such catastrophic damage to say, an electronic load cell would require the component to be replaced before the machine would function.

#### 4.7.2 CAGE STOWING

To reduce the overall length of the machine for transport purposes use the following procedure;

- 1) Elevate the telescopic booms so the cage is clear of the ground by at least 1m.
- 2) Use the auxiliary controls under the base canopy to carefully tuck the cage under the booms, taking care to avoid contact with the ground. If the cage is too close to the ground, return to step 1) and elevate the telescopic booms further before proceeding.



- 3) Once the cage is fully tucked underneath, place cardboard under the cage for protection and then use the auxiliary controls under the base canopy to lower the telescopic boom onto the boom rest as shown below. **Note: The cage can rest on the floor under its own weight, but DO NOT force the cage into the floor.**



**Operating & Safety Instructions**

**4.7.3 TOWING**

If the Niftylift needs to be towed in case of an emergency, it will be necessary to chock the wheels before starting any of the following actions.

**GEARBOX DISENGAGEMENT**

In order to safely tow the HR28, the drive mechanism will need to be bypassed. The drive gearboxes located on the front and rear wheel hubs must be disengaged as follows;

- 1) Place a suitable container under the drive hub to capture oil spillage.
- 2) Using an Allen key, remove the central plug.
- 3) Using a suitable hydraulic jack, lift the machine until the relevant wheel is clear of the ground.
- 4) Screw an M6 bolt into the central pinion and carefully pull the pinion out of the gearbox. Slight movement of the wheel may be required whilst carrying out this procedure.
- 5) Re-install the central plug.
- 6) To re-engage the gearbox, remove central plug and refit central pinion ensuring wheel is jacked up clear of the ground.
- 7) Re-install central plug.
- 8) Top up gearbox oil as required, ensure drain plugs are horizontal (see diagram).

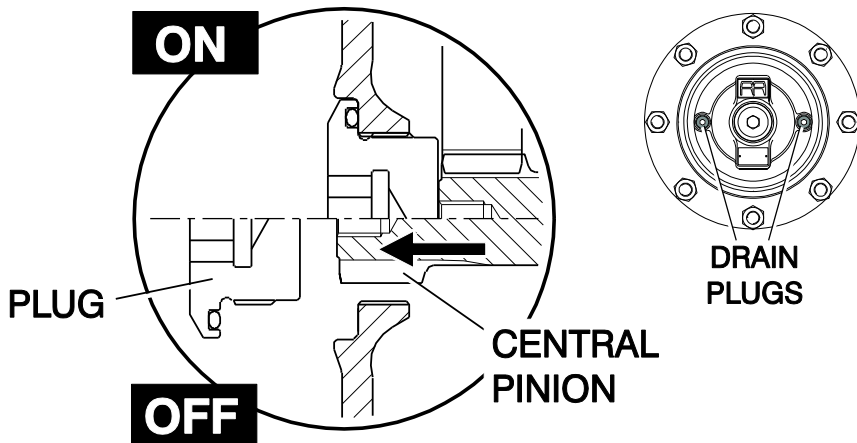

**4.7.4 CRANEAGE**

- 1) Observe all of the limitations relating to straps and chains stated above under 'Transporting'. (4.7.1)
- 2) When utilising the designated lifting points never apply a 'snatch' load, i.e. lift slowly to take up the load before raising. Similarly, do not drop machine when positioning after lifting.
- 3) If the machine is to be lifted by crane, use the designated lifting points and observe the recommendations regarding spreader beams. Individual drawings are available for each machine type, on request. (See list below.)

**D81742 HR28**

#### **4.7.5 STORAGE**

If being stored for any length of time without use, then the machine should be thoroughly inspected for the following:-

- 1) Grease all bearings /slides, worm drives, etc.
- 2) Check batteries for state of charge, damage, dirt, etc. Ensure batteries are **fully charged** before storage. If no use of the platform is intended, an occasional "top-up" charge of the batteries will serve to equalise their charge level. **Never leave in a state of discharge for any length of time.** Refer to HR28 MK2 Service Manual for further information.
- 3) Leave battery disconnect switch in **OFF** position to prevent discharge of batteries through leakage.
- 4) If machine is to be left on an incline, chock wheels to prevent creep.
- 5) If machine is to be left outside or in a hostile environment, cover with suitable weatherproof media to prevent deterioration.

#### **4.7.6 SETTING TO WORK**

Before use each day and at the beginning of each shift the machine shall be given a visual and functional test including, but not limited to, the following

- 1) Check all lubrication points for adequate application of grease, oil etc.
- 2) Inspect all threads for ease of operation - especially descent valves, brake release valve etc.
- 3) Check level and quantity of oil. Remove any contaminants - water, etc.
- 4) Check batteries for state of charge.
- 5) Check electrics for damage and insulation.
- 6) Using ground controls, cycle machine over complete envelope in accordance with the Operating Instructions. Cure any defects.
- 7) Ensure that all safety devices and controls operate in accordance with the instructions.
- 8) If necessary, perform a load test to establish machine stability before putting the machine to work.
- 9) On completion of an extended period of road transport, the machine might need additional inspection to identify any transit degradation, which could render the machine unsafe. Perform a Pre-delivery Inspection on the unit before it enters service. Record any faults found and rectify them immediately.
- 10) If left un-attended for an extended period, it is likely that the hydraulic cage levelling will become un-pressurised. Normal operation is then lost, with a noticeable delay in the forwards or backwards motion as the booms move. To restore normal function, operate the cage-levelling function at the Ground Control Station, the cage needs to be fully levelled forwards and backwards. When the system has been charged in both directions, the cage levelling function should be restored. Repeat the procedure as described above until the movements are smooth and un-interrupted. If in doubt, contact our Service Department for further advice.

## ***nifty* Height Rider/SP Series**

---

### **Operating & Safety Instructions**

Niftylift Limited is not liable for any third party damage caused during transport. Careful attention to correct procedures will prevent many of the small snags that can happen in transit. Re-work is both expensive and time consuming. A defective machine arriving at the place of work is a poor advertisement for our product, the company's reputation and those of our dealers and clients. The responsibility for safe and damage-free transport rests with the haulier or their representatives.

## 5 Emergency Controls

### 5.1 GENERAL

**CHECKING THE OPERATION OF THE EMERGENCY CONTROLS EVERY DAY AND/OR BEFORE EACH SHIFT IS AN ESSENTIAL PART OF THE OPERATOR'S DUTIES**



The operator and all ground personnel must be thoroughly familiar with the location and operation of the emergency controls.

### 5.2 IN THE EVENT OF AN INCAPACITATED OPERATOR

Turn the key switch at the ground control station to **ground** (central position).  
Manoeuvre the machine using the ground controls as described previously in Section 4.2.

### 5.3 IN THE EVENT OF MACHINE FAILURE

If all machine power is lost, the **Auxiliary Descent Pump** can be used to provide the hydraulic power to manoeuvre the machine. If initial movement of the machine allows the master alarm to reset, normal controls will be available. This is then the fastest method of lowering the platform to the ground.

**Note:** If the machine is fitted with a cage overload system, and the cage comes into contact with a fixed object whilst operating at height, this would be detected as an overload condition. All power to the machine controls would be lost, requiring the machine to be recovered using the **Auxiliary Descent Pump**. It is sufficient for the cage to be manoeuvred away from the collision point to re-set the cage weigh mechanism, thereby restoring normal machine operation. The cage can now be lowered using the controls as described previously in Section 4.3.

**FOLLOWING AN EMERGENCY DESCENT RECOVERY OF THE PLATFORM, FULLY EXTEND AND RETRACT ALL CYLINDERS FROM GROUND CONTROL STATION BEFORE USING THE MACHINE.**



### 5.4 INCIDENT NOTIFICATION

It is a mandatory requirement that any accident or incident involving a Niftylift, regardless of whether any party received injury or property was damaged is reported by telephone directly to Niftylift. Failure to do so may render any warranty on the machine void.

## **6 Responsibilities**

### **6.1 CHANGES IN OWNERSHIP**

When a change of ownership of a Niftylift occurs, it shall be the responsibility of the seller to notify Niftylift directly of the unit, model and serial number and the name and address of the new owner within 60 days. This important step is required so that any relevant Technical Bulletins are able to reach the registered owner of each machine without delay. Please note warranties are not transferable.

### **6.2 MANUAL OF RESPONSIBILITIES (USA only)**

You are required by ANSI/SIA 92.5 2006, to read and understand your responsibilities before you use or operate this aerial platform. Please read the enclosed document, as failure to do so could result in death or serious injury. Wherever any contradiction may appear, the Manual of Responsibilities shall take precedence over all other documents.

**6.3 INSPECTION/SERVICE/PRE-HIRE CHECK LIST**

**MACHINE SERIAL NO** \_\_\_\_\_

<b>ADMINISTRATION</b>	<b>PASS</b>	<b>FAIL</b>	
<b>Daily, Weekly, Monthly</b> checks carried out as outlined in manufacturers Operating and Safety Manual?			
Machine has valid LOLER Certificate? (UK only)			
<b>TOWING</b>	<b>PASS</b>	<b>FAIL</b>	<b>N/A</b>
Check brakes are released or...			
Check wheel gearboxes disengage when required			
<b>AXLES, WHEELS AND BRAKES</b>			
Axles are secure			
Wheels are secure, tyre condition acceptable			
Wheel alignment and tracking correct			
Wheel nut torque correct			
Operation of front and rear steer functions			
Pivot pins and swing bolts secure			
<b>BASE</b>			
Operation of Emergency Stop button			
Operation of Base control valve and buttons			
Operation of all booms over full range			
Platform maintains level over full range			
Hoses not tight, kinked or fouled			
Operation of auxiliary descent pump			
Operation of tilt sensor when driven elevated on slope >5°			
Pivot pins and swing bolts secure			
<b>BOOMS</b>			
Inspect for damaged, distorted or loose components			
Wear pads present and secure			
Cylinders are silent and not fouling during operation			
Cylinders do not drift when machine is switched off			
Operation of micro switches			
Chain inspection - Correctly tensioned, damage etc.			
Energy chain correct and secure over tele function range			
Bushes (Condition check)			
Pivot pins and swing bolts secure			

# **nifty** Height Rider/SP Series

## Operating & Safety Instructions

<b>PLATFORM</b>	<b>PASS</b>	<b>FAIL</b>	<b>N/A</b>
Operation of Emergency Stop button			
Operation of SiOPS (Refer to Section 4.3.5)			
Operation of control valve and control panel buttons/switches			
Operation of all booms over full range			
Operation of Footswitch			
Platform levelling over full range			
Slewing smooth over full range			
Condition of harness points			
Condition and operation of entry/exit drop gate			
<b>POWER SYSTEM</b>			
All cables and terminals secure			
All hose connections secure			
Charger/control box secure			
Battery secure			
Hydraulic oil level			
<b>SLEWING</b>			
Slew gearbox and motor are secure			
Slew wheel bolts secured			
Slew guards secure			
<b>FINISH</b>			
Serial plate against documentation			
Check all decals in place and legible			
Canopies in place and secure			
Check all guards are in place and in good condition			
Grease nipples (Slew ring, Steer pins)			
<b>LEAK CHECK</b>			
Hydraulic Cylinders (Lift, Telescope, Levelling)			
Control valves			
Check valves			
Power system pump			
Filters			
Slew motor			
Hydraulic Hose connections and fittings			

**Note; Environmental factors and usage amount will affect the type of checks and also the frequency of inspection intervals.**

***nifty* Height Rider/SP Series**  
**Operating & Safety Instructions**

---

**Comments, remedial work required etc;**

**INSPECTED BY:** \_\_\_\_\_

**DATE:**    /    /

**Appendix A****Error codes**

For more comprehensive error information please refer to the HR28 MK2 Service Manual.

<b>Error Code</b>	<b>Description</b>	<b>Action</b>
<b>0101101</b>	There is a break on the motion beacon (PIN 45) output	Contact a Niftylift approved service centre.
<b>0101102</b>	There is a short on the motion beacon (PIN 45) output	Contact a Niftylift approved service centre.
<b>01011301</b>	There is a break on the base override button LED (PIN 47) output	Contact a Niftylift approved service centre.
<b>01011302</b>	There is a short on the base override button LED (PIN 47) output	Contact a Niftylift approved service centre.
<b>01011401</b>	There is a break on the Luffing up (PIN 36) output	Contact a Niftylift approved service centre.
<b>01011402</b>	There is a short on the Luffing up (PIN 36) output	Contact a Niftylift approved service centre.
<b>01011501</b>	There is a break on the Luffing down (PIN 54) output	Contact a Niftylift approved service centre.
<b>01011502</b>	There is a short on the Luffing down (PIN 54) output	Contact a Niftylift approved service centre.

***nifty* Height Rider/SP Series**  
**Operating & Safety Instructions**

<b>Error Code</b>	<b>Description</b>	<b>Action</b>
<b>01011601</b>	There is a break on the cage level up (PIN 17) output	Contact a Niftylift approved service centre.
<b>01011602</b>	There is a short on the cage level up (PIN 17) output	Contact a Niftylift approved service centre.
<b>01011701</b>	There is a break on the cage level down (PIN 53) output	Contact a Niftylift approved service centre.
<b>01011702</b>	There is a short on the cage level down (PIN 53) output	Contact a Niftylift approved service centre.
<b>01011801</b>	There is a break on the machine active (PIN 39) output	Contact a Niftylift approved service centre.
<b>01011802</b>	There is a short on the machine active (PIN 39) output	Contact a Niftylift approved service centre.
<b>01011A01</b>	There is a break on the auxiliary contactor 2 (PIN 40) output	Contact a Niftylift approved service centre.
<b>01011A02</b>	There is a short on the auxiliary contactor 2 (PIN 40) output	Contact a Niftylift approved service centre.
<b>01011B01</b>	There is a break on the alarm sounder (PIN 22) output	Contact a Niftylift approved service centre.

**Operating & Safety Instructions**

<b>Error Code</b>	<b>Description</b>	<b>Action</b>
<b>01011B02</b>	There is a short on the alarm sounder (PIN 22) output	Contact a Niftylift approved service centre.
<b>01011D01</b>	There is a break on the warning lamp (PIN 42) output	Contact a Niftylift approved service centre.
<b>01011D02</b>	There is a short on the warning lamp (PIN 42) output	Contact a Niftylift approved service centre.
<b>01011F01</b>	There is a break on the generator enable (PIN 04) output	Contact a Niftylift approved service centre.
<b>01011F02</b>	There is a short on the generator enable (PIN 04) output	Contact a Niftylift approved service centre.
<b>01012001</b>	There is a break on the base green button LED (PIN 48) output	Contact a Niftylift approved service centre.
<b>01012002</b>	There is a short on the base green button LED (PIN 48) output	Contact a Niftylift approved service centre.
<b>01012101</b>	There is a break on the drive enable (PIN 49) output	Contact a Niftylift approved service centre.
<b>01012102</b>	There is a short on the drive enable (PIN 49) output	Contact a Niftylift approved service centre.

***nifty* Height Rider/SP Series**  
**Operating & Safety Instructions**

<b>Error Code</b>	<b>Description</b>	<b>Action</b>
<b>01012201</b>	There is a break on the motion sounder (PIN 31) output	Contact a Niftylift approved service centre.
<b>01012202</b>	There is a short on the motion sounder (PIN 31) output	Contact a Niftylift approved service centre.
<b>01012301</b>	There is a break on the auxiliary contactor 1 (PIN 50) output	Contact a Niftylift approved service centre.
<b>01012302</b>	There is a short on the auxiliary contactor 1 (PIN 50) output	Contact a Niftylift approved service centre.
<b>01012401</b>	There is a break on the boom enable (PIN 51) output	Contact a Niftylift approved service centre.
<b>01012402</b>	There is a short on the boom enable (PIN 51) output	Contact a Niftylift approved service centre.
<b>01012501</b>	There is a break on the safety relay 1 (PIN 52) output	Contact a Niftylift approved service centre.
<b>01012502</b>	There is a short on the safety relay 1 (PIN 52) output	Contact a Niftylift approved service centre.
<b>01012601</b>	There is a break on the safety relay 2 (PIN 16) output	Contact a Niftylift approved service centre.

**Operating & Safety Instructions**

<b>Error Code</b>	<b>Description</b>	<b>Action</b>
<b>01012602</b>	There is a short on the safety relay 2 (PIN 16) output	Contact a Niftylift approved service centre.
<b>01012701</b>	There is a break on the horn (PIN 35) output	Contact a Niftylift approved service centre.
<b>01012702</b>	There is a short on the horn (PIN 35) output	Contact a Niftylift approved service centre.
<b>01021601</b>	There is a break on the warning lamp (PIN 17) output	Contact a Niftylift approved service centre.
<b>01021602</b>	There is a short on the warning lamp (PIN 17) output	Contact a Niftylift approved service centre.
<b>01021701</b>	There is a break on the cage override button LED (PIN 53) output	Contact a Niftylift approved service centre.
<b>01021702</b>	There is a short on the cage override button LED (PIN 53) output	Contact a Niftylift approved service centre.
<b>01022001</b>	There is a break on the motion sounder (PIN 48) output	Contact a Niftylift approved service centre.
<b>01022002</b>	There is a short on the motion sounder (PIN 48) output	Contact a Niftylift approved service centre.

**nifty** Height Rider/SP Series  
Operating & Safety Instructions

<b>Error Code</b>	<b>Description</b>	<b>Action</b>
<b>01022101</b>	There is a break on the motion beacon (PIN 49) output	Contact a Niftylift approved service centre.
<b>01022102</b>	There is a short on the motion beacon (PIN 49) output	Contact a Niftylift approved service centre.
<b>01022301</b>	There is a break on the cage enable (PIN 50) output	Contact a Niftylift approved service centre.
<b>01022302</b>	There is a short on the cage enable (PIN 50) output	Contact a Niftylift approved service centre.
<b>01022401</b>	There is a break on the cage green button LED (PIN 51) output	Contact a Niftylift approved service centre.
<b>01022402</b>	There is a short on the cage green button LED (PIN 51) output	Contact a Niftylift approved service centre.
<b>01022501</b>	There is a break on the 6/2 valve (PIN 52) output	Contact a Niftylift approved service centre.
<b>01022502</b>	There is a short on the 6/2 valve (PIN 52) output	Contact a Niftylift approved service centre.
<b>01031001</b>	There is a break on the drive backward (PIN 44) output	Contact a Niftylift approved service centre.

# **nifty** Height Rider/SP Series

## **Operating & Safety Instructions**

<b>Error Code</b>	<b>Description</b>	<b>Action</b>
<b>01031002</b>	There is a short on the drive backward (PIN 44) output	Contact a Niftylift approved service centre.
<b>01031101</b>	There is a break on the drive forward (PIN 45) output	Contact a Niftylift approved service centre.
<b>01031102</b>	There is a short on the drive forward (PIN 45) output	Contact a Niftylift approved service centre.
<b>01031201</b>	There is a break on the displacement change (PIN 46) output	Contact a Niftylift approved service centre.
<b>01031202</b>	There is a short on the displacement change (PIN 46) output	Contact a Niftylift approved service centre.
<b>01031301</b>	There is a break on the diff lock (PIN 47) output	Contact a Niftylift approved service centre.
<b>01031302</b>	There is a short on the diff lock (PIN 47) output	Contact a Niftylift approved service centre.
<b>01031401</b>	There is a break on the steer left (PIN 36) output	Contact a Niftylift approved service centre.
<b>01031402</b>	There is a short on the steer left (PIN 36) output	Contact a Niftylift approved service centre.

***nifty* Height Rider/SP Series**  
**Operating & Safety Instructions**

<b>Error Code</b>	<b>Description</b>	<b>Action</b>
<b>01031501</b>	There is a break on the steer right (PIN 54) output	Contact a Niftylift approved service centre.
<b>01031502</b>	There is a short on the steer right (PIN 54) output	Contact a Niftylift approved service centre.
<b>01032001</b>	There is a break on the front brake release (PIN 48) output	Contact a Niftylift approved service centre.
<b>01032002</b>	There is a short on the front brake release (PIN 48) output	Contact a Niftylift approved service centre.
<b>01032301</b>	There is a break on the rear brake release (PIN 50) output	Contact a Niftylift approved service centre.
<b>01032302</b>	There is a short on the rear brake release (PIN 50) output	Contact a Niftylift approved service centre.
<b>01032401</b>	There is a break on the elevated drive (PIN 51) output	Contact a Niftylift approved service centre.
<b>01032402</b>	There is a short on the elevated drive (PIN 51) output	Contact a Niftylift approved service centre.
<b>01032701</b>	There is a break on the suspension enable (PIN 35) output	Contact a Niftylift approved service centre.

## **nifty** Height Rider/SP Series

### Operating & Safety Instructions

<b>Error Code</b>	<b>Description</b>	<b>Action</b>
<b>01032702</b>	There is a short on the suspension enable (PIN 35) output	Contact a Niftylift approved service centre.
<b>019D0000</b>	The suspension pressure reading is out of its allowable range	Contact a Niftylift approved service centre.
<b>019E0000</b>	The cage weight analogue reading is outside of its allowable range	Contact a Niftylift approved service centre.
<b>019F0000</b>	The steer position sensor reading is outside of its allowable range	Contact a Niftylift approved service centre.
<b>01A00000</b>	The SiOPS switch contacts are not reading correctly	Contact a Niftylift approved service centre.
<b>01A10000</b>	The keyswitch contacts are not reading correctly	Contact a Niftylift approved service centre.
<b>01A20000</b>	The Base E-Stop contacts are not reading correctly	Contact a Niftylift approved service centre.
<b>01A30000</b>	The Cage E-Stop contacts are not reading correctly	Contact a Niftylift approved service centre.
<b>01A40000</b>	The cage weigh safety inputs are not reading correctly	Contact a Niftylift approved service centre.

**nifty** Height Rider/SP Series  
Operating & Safety Instructions

<b>Error Code</b>	<b>Description</b>	<b>Action</b>
<b>01A50000</b>	The boom down switch contacts are not reading correctly	Contact a Niftylift approved service centre.
<b>01A60000</b>	The Telescope in switch contacts are not reading correctly	Contact a Niftylift approved service centre.
<b>01A70000</b>	The mode select switch contacts are not reading correctly	Contact a Niftylift approved service centre.
<b>01A80000</b>	The cage rotate switch (Cage) contacts are not reading correctly	Contact a Niftylift approved service centre.
<b>01A90000</b>	The White button (Cage) contacts are not reading correctly	Contact a Niftylift approved service centre.
<b>01AA0000</b>	The Joystick steer switch contacts are not reading correctly	Contact a Niftylift approved service centre.
<b>01AB0000</b>	The pressure sensor reading is outside of its range (Low)	Contact a Niftylift approved service centre.
<b>01AC0000</b>	The pressure sensor reading is outside of its range (High)	Contact a Niftylift approved service centre.
<b>01AD0000</b>	The hydraulic pressure is outside of its allowable range during elevated drive use	Contact a Niftylift approved service centre.

**Operating & Safety Instructions**

<b>Error Code</b>	<b>Description</b>	<b>Action</b>
<b>01AE0000</b>	The Green Button (Base) contacts are not reading correctly	Contact a Niftylift approved service centre.
<b>01AF0000</b>	The Green Button (Cage) contacts are not reading correctly	Contact a Niftylift approved service centre.
<b>01B00000</b>	The Cage Level buttons (Cage) are not reading correctly	Contact a Niftylift approved service centre.
<b>01B10000</b>	The Links boom paddle (Cage) has malfunctioned - neutral position	Return the paddle to the neutral position and reapply demand after providing a green button or footswitch enable. Ensure the paddle is returning to the neutral position when released and if the problem persists, contact a Niftylift approved service centre.
<b>01B20000</b>	The Luffing boom paddle (Cage) has malfunctioned - neutral position	Return the paddle to the neutral position and reapply demand after providing a green button or footswitch enable. Ensure the paddle is returning to the neutral position when released and if the problem persists, contact a Niftylift approved service centre.
<b>01B30000</b>	The Slew boom paddle (Cage) has malfunctioned - neutral position	Return the paddle to the neutral position and reapply demand after providing a green button or footswitch enable. Ensure the paddle is returning to the neutral position when released and if the problem persists, contact a Niftylift approved service centre.
<b>01B40000</b>	The Telescope boom paddle (Cage) has malfunctioned - neutral position	Return the paddle to the neutral position and reapply demand after providing a green button or footswitch enable. Ensure the paddle is returning to the neutral position when released and if the problem persists, contact a Niftylift approved service centre.
<b>01B50000</b>	The Fly boom paddle (Cage) has malfunctioned - neutral position	Return the paddle to the neutral position and reapply demand after providing a green button or footswitch enable. Ensure the paddle is returning to the neutral position when released and if the problem persists, contact a Niftylift approved service centre.
<b>01B60000</b>	The Drive Joystick has malfunctioned - neutral position	Return the joystick to the neutral position and reapply demand after providing a green button or footswitch enable. Ensure the joystick is returning to the neutral position when released and if the problem persists, contact a Niftylift approved service centre.

**nifty** Height Rider/SP Series  
**Operating & Safety Instructions**

<b>Error Code</b>	<b>Description</b>	<b>Action</b>
<b>01B70000</b>	The White button (Base) contacts are not reading correctly	Contact a Niftylift approved service centre.
<b>01C10000</b>	There is no CANBus communication with the Battery Management Node (Acuity - Node 42)	Contact a Niftylift approved service centre.
<b>01C20000</b>	There is no CANBus communication with the Drive Joystick (Node 32)	Contact a Niftylift approved service centre.
<b>01C30000</b>	There is no CANBus communication with the Cage CAN Node (Node 3)	Contact a Niftylift approved service centre.
<b>01C40000</b>	There is no CANBus communication with the Motor Controller (Node 4)	Contact a Niftylift approved service centre.
<b>01C50000</b>	There is no CANBus communication with the Engine Controller (Node 5)	Contact a Niftylift approved service centre.
<b>01C60000</b>	There is no CANBus communication with the Master drive Motor Controller (Node 3)	Contact a Niftylift approved service centre.
<b>01C70000</b>	There is no CANBus communication with the Slave drive Motor Controller (Node 4)	Contact a Niftylift approved service centre.
<b>01C80000</b>	There is no CANBus communication with the Cage Display (Node 8)	Contact a Niftylift approved service centre.

**Operating & Safety Instructions**

<b>Error Code</b>	<b>Description</b>	<b>Action</b>
<b>01C90000</b>	There is no CANBus communication with the Base Display (Node 9)	Contact a Niftylift approved service centre.
<b>02CA0000</b>	There is no CANBus communication with Cage PLC (Node 2)	Contact a Niftylift approved service centre.
<b>02CB0000</b>	There is no CANBus communication with the Chassis PLC (Node 29)	Contact a Niftylift approved service centre.
<b>01CC0000</b>	There is no CANBus communication with the Boom2 Inclination sensor (Node 12)	Contact a Niftylift approved service centre.
<b>01CD0000</b>	There is no CANBus communication with the Boom3 Inclination sensor (Node 13)	Contact a Niftylift approved service centre.
<b>01CE0000</b>	There is no CANBus communication with the Valve Driver (Axiomatic - Node 7)	Contact a Niftylift approved service centre.
<b>01CF0000</b>	There is no CANBus communication with the Chassis inclination sensor (Node 15)	Contact a Niftylift approved service centre.
<b>01D10000</b>	There is a suspected malfunction on either a Green Button, White Button or the Footswitch	Contact a Niftylift approved service centre.
<b>01D20000</b>	There is a suspected malfunction with the Joystick Trigger	The joystick trigger has been held active for too long without a movement demand. Release the trigger and re-apply with a movement demand. If the problem persists, contact a Niftylift approved service centre.

**nifty** Height Rider/SP Series  
Operating & Safety Instructions

<b>Error Code</b>	<b>Description</b>	<b>Action</b>
<b>01D30000</b>	The Chassis Inclination sensor (X) reading is outside the allowable offset range	Contact a Niftylift approved service centre.
<b>01D40000</b>	The Chassis Inclination sensor (Y) reading is outside the allowable offset range	Contact a Niftylift approved service centre.
<b>01D50000</b>	The Chassis Inclination sensor requires calibration (X)	Contact a Niftylift approved service centre.
<b>01D60000</b>	The Chassis Inclination sensor requires calibration (Y)	Contact a Niftylift approved service centre.
<b>01D70000</b>	The Steer position sensor requires calibration	Contact a Niftylift approved service centre.
<b>01D80000</b>	The Steer position sensor reading is outside the allowable range for calibration	Contact a Niftylift approved service centre.
<b>01D90000</b>	The Cage Level inclination sensor requires calibration	Contact a Niftylift approved service centre.
<b>01DA0000</b>	The Cage Level inclination sensor is outside the allowable range for calibration	Contact a Niftylift approved service centre.
<b>01DB0000</b>	There is no CANBus communication with the Cage Level Inclination Sensor (Node 14)	Contact a Niftylift approved service centre.

**Operating & Safety Instructions**

<b>Error Code</b>	<b>Description</b>	<b>Action</b>
<b>01E10000</b>	The Links boom paddle (Cage) has malfunctioned - channel error	Return the Links paddle to the neutral position and re-attempt. If the problem persists, contact a Niftylift approved service centre.
<b>01E20000</b>	The Luffing boom paddle (Cage) has malfunctioned - channel error	Return the Luffing paddle to the neutral position and re-attempt. If the problem persists, contact a Niftylift approved service centre.
<b>01E30000</b>	The Slew boom paddle (Cage) has malfunctioned - channel error	Return the Slew paddle to the neutral position and re-attempt. If the problem persists, contact a Niftylift approved service centre.
<b>01E40000</b>	The Telescope boom paddle (Cage) has malfunctioned - channel error	Return the Telescope paddle to the neutral position and re-attempt. If the problem persists, contact a Niftylift approved service centre.
<b>01E50000</b>	The Fly boom paddle (Cage) has malfunctioned - channel error	Return the Fly paddle to the neutral position and re-attempt. If the problem persists, contact a Niftylift approved service centre.
<b>01E60000</b>	The Drive Joystick has malfunctioned - channel error	Return the drive joystick to the neutral position and re-attempt. If the problem persists, contact a Niftylift approved service centre.
<b>01F10000</b>	There is an error with the Motor Controller	Check the motor controller flash code or application specific error code (last two bytes) for further information.
<b>01F20000</b>	The machine power type has not been selected	Contact a Niftylift approved service centre.
<b>01F30000</b>	The machine serial number has not been set	Contact a Niftylift approved service centre.

<b>Error Code</b>	<b>Description</b>	<b>Action</b>
<b>01F40000</b>	The machine is in "Download" mode	Contact a Niftylift approved service centre.
<b>01F50000</b>	The "Engine Protect" warning has been triggered	Engine coolant temperature high or oil pressure low. If coolant temperature is high, allow time to cool. If the problem persists, contact a Niftylift approved service centre.
<b>01F60000</b>	The battery temperature is high (>80 degrees)	Check all battery terminal connections are tight and free of corrosion. Allow batteries to cool and if problem persists, contact a Niftylift approved service centre.
<b>01F90000</b>	Suspension pressure too high whilst elevated	Contact a Niftylift approved service centre.
<b>01FA0000</b>	Main hydraulic power has been disabled due to a safety related error	Power cycle the machine and if the problem persists, contact a Niftylift approved service centre.
<b>01FB0000</b>	Auxiliary hydraulic power has been disabled due to a safety related error	Power cycle the machine and if the problem persists, contact a Niftylift approved service centre.
<b>01FC0000</b>	There is an error with the Auxiliary pump contactors	Contact a Niftylift approved service centre.
<b>01FD0000</b>	The Auxiliary pump battery system voltage is outside of its allowable range	Contact a Niftylift approved service centre.
<b>01FE0000</b>	There is an error with the Charge Algorithm selected with the charger	Contact a Niftylift approved service centre.

## Appendix B

### Safety Related Parts of the Control System (SRP/CS)

The Niftylift control system has been designed and validated according to the required standards. The table below lists the safety related parts of the control system and the level to which they have been approved.

The performance level (PL) of each SRP/CS is specified by BS EN 280:2013+A1 2015 section 5.11 Table 5.

Safety Related Part of the Control System (SRP/CS)	Approval (Standard, Performance Level)
<b>B1</b> Prevent travel above inclination limit	ISO 13849-1:2015 PL c
<b>B2</b> Limitation of travelling speed	ISO 13849-1:2015 PL c
<b>B3</b> Control of oscillating axles	ISO 13849-1:2015 PL d
<b>B4</b> Load sensing system	ISO 13849-1:2015 PL d
<b>B5</b> Platform levelling	ISO 13849-1:2015 PL d
<b>B6</b> Prevent movements of load holding cylinders in case of pipe failure	ISO 13849-1:2015 PL c
<b>B7</b> Interlocking of travel controls	ISO 13849-1:2015 PL b
<b>B8</b> Emergency Stop	BS EN ISO 13850:2015 PLc
<b>B9</b> SiOPS	BS EN ISO 13849-1:2015 PLd
<b>B10</b> Auxiliary override	BS EN ISO 13849-1:2015 PLd

### **B1 PREVENT TRAVEL ABOVE INCLINATION LIMIT (PTAIL)**

The tilt detection system is designed to meet the requirements of PLc in accordance with ISO 13849-1:2015 as required by BS EN 280:2013+A1 2015.

*1. The limits of the safety-related parts to the category selected and any fault exclusions;*

The tilt detection system is active when the machine is out of its stowed position i.e. when telescope booms are off the booms rest and fully retracted.

Drive is permitted when the chassis angle exceeds the rated angle providing the telescope boom is retracted so the telescope boom switch is actuated and on the booms rest so the boom switch is actuated. The boom and telescope switches rely on their respective electrical contacts switching allowing the tilt system to permit drive whilst out of the rated angle.

The switching of the contacts to the stowed position is positively driven by the weight of the telescope boom on the booms rest and the force of the telescope boom fully retracting.

The switching of the contacts to the raised position is forced by the use of the spring contained within the booms rest and telescope boom switch assembly. **Proper maintenance and daily safety checks to be observed**

The booms rest or telescope boom switch cannot be overridden to bypass the tilt system other than by demounting the switch with the use of tools. **Reasonably foreseeable misuse**

If the boom or tele switches are removed or if they are not maintained in accordance with the appropriate documentation, the muting of the tilt detection system may not activate and could lead to machine stability and overturning.

Both telescope and boom switches are designed to utilise mechanically linked contacts which ensures that both sets of contacts actuate simultaneously.. The two sets of contacts in each switch are checked against one another to prevent a failure in either switch leading to the loss of the safety function.

*2.The limits of the SRP/CS and any fault exclusion, for which, when essential for maintaining the selected category or categories and safety performance, appropriate information (e.g. for modification, maintenance and repair) shall be given to ensure the continued justification of the fault exclusion(s); Do not alter, modify or disable in any way the controls, safety devices, interlocks or any other part of the machine.*

Maintenance must only be carried out by appropriately trained and competent persons.

*3.The effects of deviations from the specified performance on the safety function(s);*

If the tilt sensor does not function as intended it is possible that the Niftylift may encounter slopes for which it is not rated when out of its stowed position.

If the Niftylift encounters slopes beyond the rating as specified on the serial plate the product may become unstable.

If the product becomes unstable, there is a risk of damage to the Niftylift, other equipment and properties, injury or loss of life of the operator and surrounding persons..

If the booms rest switch does not function as intended it is possible the Niftylift will not mute the tilt detection system when intended.

If the telescope switch does not function as intended it is possible the Niftylift will not mute the tilt detection system when intended.

The system has been tested in its application and if a fault occurs, the system will always fail to a safe state i.e. Drive will be disabled.

*4.Clear descriptions of the interfaces to the SRP/CS and protective devices;*

The PTAIL safety function system comprises of three safety PLCs, the tilt sensor, the booms rest switch, the telescope switch, the front brake release valve and the rear brake release valve.

The tilt sensor and booms rest switch inputs in the base safety PLC, the telescope switch inputs into the cage safety PLC and the front and rear brake release solenoids are outputs from the chassis safety PLC.

All safety PLCs and the tilt sensor are connected by the CANbus.

*5.Response time*

The tilt sensor is energised and active at all times providing the correct signal in relation to the angle of inclination of the chassis in the x and y axis. The booms rest and telescope switches are active at all times providing the correct signals in relation to the position of the booms.

In the event of encountering an angle of inclination greater than is allowable the system will prevent drive functions by applying the front and rear brakes.

The time taken to stop the machine on a gradual slope when the rated inclination is reached will not lead to an unsafe situation.

## **Operating & Safety Instructions**

### *6. Operating limits (including environmental conditions);*

All components within the tilt interlock are rated to the environmental conditions acceptable for the machine; refer to Section 2.2.

### *7. Indications and alarms;*

Tilt alarm

If the booms are raised and the allowable tilt limit is detected, the action of the tilt alarm will cause the klaxon to sound and the red warning light at the base and cage control location will illuminate. ,

### *8. Muting and suspension of safety functions;*

The tilt sensor is always energised and active, but the safety function is suspended while the telescope boom is on the boom rest and fully retracted. Warning lights indicate if the angle of inclination has been exceeded regardless of the boom position.

### *9. Control modes;*

The tilt detection system has no user controllable modes of operation.

### *10. Maintenance; Maintenance check lists;*

Please see service manual for all maintenance details.

### *Ease of accessibility and replacing of internal parts;*

Replacement of parts should only be carried out by appropriately trained and competent persons.

If parts require replacement, only replace the whole component, such as Tilt Sensor, Safety Switch, PLC or Hydraulic valve block.

Do not attempt to open the tilt sensor or replace components soldered to any PLC.

Do not attempt maintenance of hydraulic components i.e. replace seals or an internal component.

Only Niftylift original and supplied parts shall be used.

### *12. Means for easy and safe trouble shooting;*

To check the operation of the tilt sensor system

With booms slightly raised, drive onto a slope equal to the rated angle of the machine. The machine brakes should halt the machine as soon as the level is reached.

### *13. Information explaining the applications for use relevant to the category to which reference is made;*

Not applicable.

### *14. Checking test intervals where relevant.*

Check the operation of the tilt sensor system to be made at the beginning of every duty cycle.

## **B2 LIMITATION OF TRAVELLING SPEED (LOTS)**

The elevated drive speed interlock, also known as the elevated drive speed system, is designed to meet the requirements of PLc in accordance with ISO 13849-1:2015 as required by BS EN 280:2013+A1 2015.

*1. The limits of the safety-related parts to the category selected and any fault exclusions;*

The elevated drive speed system is muted when the machine is stowed i.e. when telescope booms are on the booms rest and the boom switch is actuated and the telescope booms retracted such that the telescope boom switch is actuated.

The full driving speed is permitted when the telescope boom is retracted so the telescope boom switch is actuated and on the booms rest so the boom switch is actuated. The boom and telescope switches rely on their respective electrical contacts switching allowing the tilt system to permit drive whilst out of the rated angle.

The switching of the contacts to the stowed position is positively driven by the weight of the telescope boom on the booms rest and the force of the telescope boom fully retracting.

The switching of the contacts to the raised position is forced by the use of the spring contained within the booms rest and telescope boom switch assembly. **Proper maintenance and daily safety checks to be observed**

The booms rest or telescope boom switch cannot be overridden to bypass the tilt system other than by demounting the switch with the use of tools. **Reasonably foreseeable misuse**

**NOTE: The Slew position will also affect drive speeds. To operate at full speed, ensure the slew is centred.**

*2. The limits of the SRP/CS and any fault exclusion, for which, when essential for maintaining the selected category or categories and safety performance, appropriate information (e.g. for modification, maintenance and repair) shall be given to ensure the continued justification of the fault exclusion(s);*

Maintenance must only be carried out by appropriately trained and competent persons.

*3. The effects of deviations from the specified performance on the safety function(s);*

If the elevated drive speed interlock does not function as intended it is possible that the Niftylift may experience dramatic dynamic effects which may adversely affect the stability of the product.

If the product becomes unstable, damage to the Niftylift, other equipment and properties, injury or loss of life of the operator and surrounding persons may be a risk.

If the booms rest switch does not function as intended it is possible the Niftylift will not mute the elevated drive system when intended.

If the telescope switch does not function as intended it is possible the Niftylift will not mute the elevated drive system when intended.

The system and has been tested in its application and if a fault occurs, the system will always fail to a safe state i.e. the machine would be limited to elevated drive speed.

*4. Clear descriptions of the interfaces to the SRP/CS and protective devices;*

The limitation of travel speed (LOTS) safety function comprises of the 3 safety PLCs, the booms rest switch, the telescope switch and elevated drive solenoid.

## **Operating & Safety Instructions**

The booms rest switch inputs in the base safety PLC, the telescope switch inputs into the cage safety PLC and the elevated drive solenoid are outputs from the chassis safety PLC.

All safety PLCs are connected on the CANbus, using the CANsafe protocol.

### *5. Response time*

The booms rest and telescope switches are active at all times providing the correct signals in relation to the position of the booms.

The time taken to slow the machine when machine leaves the stowed position will not lead to an unsafe situation.

### *6. Operating limits (including environmental conditions);*

All components within the elevated drive speed are rated to the environmental conditions acceptable for the machine; refer to Section 2.2.

### *7. Indications and alarms;*

The Cage Screen will display an elevated machine icon to show that the Niftylift is under the control of the elevated drive speed interlock.

### *8. Muting and suspension of safety functions;*

It is not possible to suspend the operation of the Elevated drive speed interlock with the booms raised or the telescope sections extended.

### *9. Control modes;*

The elevated drive speed interlock has no user controllable modes of operation.

### *10. Maintenance; Maintenance check lists;*

Please see service manual for all maintenance details.

### *11. Ease of accessibility and replacing of internal parts;*

Replacement of parts should only be carried out by appropriately trained and competent persons.

If parts require replacement only replace the complete item such as Safety Switch, PLC or Hydraulic valve block.

Do not attempt to open the booms switches, other than to check the condition of the wiring to the switches.

Do not attempt maintenance of hydraulic components i.e. replace seals or internal component.

Only Niftylift original and supplied parts shall be used.

### *12. Means for easy and safe trouble shooting;*

To check the operation of the elevated drive speed system

- 1) Ensure that the Niftylift has sufficient clearance in all directions to drive for a minimum distance to ascertain that the elevated drive speed is correct.
- 2) Power on the Niftylift and select the cage control location.
- 3) Operate the booms from the cage console and elevate the links booms sufficiently to remove the telescope sections from the boom rest such that the boom switch is actuated.

- 4) Depress the joystick trigger and move the joystick in the desired direction. Test the drive forward and backwards functions in turn.
- 5) Observe that that the speed of the drive functions is no more than 1km/h. The machine should travel no further than 10 metres in 28 seconds.
- 6) Release the joystick to cease driving operations.

*13. Information explaining the applications for use relevant to the category to which reference is made;*

Not applicable.

*14. Checking test intervals where relevant.*

Check the operation of the tilt sensor system to be made at the beginning of every duty cycle.

## **Operating & Safety Instructions**

### **B3 CONTROL OF OSCILLATING AXLES (CoOA)**

The suspension interlock is designed to meet the requirements of PLd in accordance with ISO 13849-1:2015 as required by BS EN 280:2013+A1 2015.

*1. The limits of the safety-related parts to the category selected and any fault exclusions;*

The suspension interlock system is muted when the machine is stowed i.e. when telescope booms are on the booms rest and the boom switch is actuated and the telescope booms retracted such that the telescope boom switch is actuated.

The pressurising of the suspension system is permitted when the telescope boom is retracted so the telescope boom switch is actuated and on the booms rest so the boom switch is actuated. The boom and telescope switches rely on their respective electrical contacts switching allowing the tilt system to permit drive whilst out of the rated angle.

The switching of the contacts to the stowed position is positively driven by the weight of the telescope boom on the booms rest and the force of the telescope boom fully retracting.

The switching of the contacts to the raised position is forced by the use of the spring contained within the booms rest and telescope boom switch assembly. **Proper maintenance and daily safety checks to be observed**

The booms rest or telescope boom switch cannot be overridden to bypass the tilt system other than by demounting the switch with the use of tools. **Reasonably foreseeable misuse**

*2. The limits of the SRP/CS and any fault exclusion, for which, when essential for maintaining the selected category or categories and safety performance, appropriate information (e.g. for modification, maintenance and repair) shall be given to ensure the continued justification of the fault exclusion(s);*

Maintenance must only be carried out by appropriately trained and competent persons.

*3. The effects of deviations from the specified performance on the safety function(s);*

If the suspension system interlock does not function as intended it is possible that the Niftylift may experience dramatic dynamic effects which may adversely affect the stability of the product.

If the product becomes unstable, damage to the Niftylift, other equipment and properties, injury or loss of life of the operator and surrounding persons may be a risk.

If the booms rest switch does not function as intended it is possible the Niftylift will not mute the suspension system when intended.

If the telescope switch does not function as intended it is possible the Niftylift will not mute the suspension system when intended.

The system and has been tested in its application and if a fault occurs, the system will always fail to a safe state i.e. suspension de-energised.

*4. Clear descriptions of the interfaces to the SRP/CS and protective devices;*

The CoOA safety function comprises of the 3 safety PLCs, the booms rest switch, the telescope switch and elevated drive solenoid.

The booms rest switch inputs in the base safety PLC, the telescope switch inputs into the cage safety PLC and the suspension solenoid are outputs from the chassis safety PLC.

All safety PLCs are connected by the CANbus.

*5. Response time*

The booms rest and telescope switches are active at all times providing the correct signals in relation to the position of the booms.

The time taken to de-energise the suspension system when machine leave the stowed position will not lead to an unsafe situation.

*6. Operating limits (including environmental conditions);*

All components within the elevated drive speed are rated to the environmental conditions acceptable for the machine; refer to Section 2.2.

*7. Indications and alarms;*

The Cage Screen will display an elevated machine icon to show that the Niftylift is under the control of the elevated drive speed interlock.

*8. Muting and suspension of safety functions;*

It is not possible to suspend the operation of the suspension interlock with the booms raised or the telescope sections extended.

*9. Control modes;*

The elevated drive speed interlock has no user controllable modes of operation.

*10. Maintenance; Maintenance check lists;*

Please see service manual for all maintenance information

- Check correct operation of the boom and telescope switch.

*11. Ease of accessibility and replacing of internal parts;*

Replacement of parts should only be carried out by appropriately trained and competent persons.

If parts require replacement only replace the complete item such as Safety Switch, PLC or Hydraulic valve block.

Do not attempt to open the booms switches, other than to check the condition of the wiring to the switches.

Do not attempt maintenance of hydraulic components i.e. replace seals or internal component.

Only Niftylift original and supplied parts shall be used.

*12. Means for easy and safe trouble shooting;*

To check the operation of the elevated drive speed system

- 1) Ensure that the Niftylift has sufficient clearance in all directions to drive for a minimum distance to ascertain that the elevated drive speed is correct.
- 2) Power on the Niftylift and select the cage control location.
- 3) Operate the booms from the cage console and elevate the links booms sufficient to remove the telescope sections from the boom rest such that the boom switch is actuated.
- 4) Depress the joystick trigger and depress the joystick in the desired direction by the use of the drive forward and backwards functions in turn.

## **Operating & Safety Instructions**

---

- 7) Observe that the speed of the drive functions is no more than 1km/h. The machine should travel no further than 10 metres in 28 seconds.
- 8) Release the joystick to cease driving operations.

*13. Information explaining the applications for use relevant to the category to which reference is made;*  
Not applicable.

*14. Checking test intervals where relevant.*

Check the operation of the tilt sensor system to be made at the beginning of every duty cycle.

## **B4 LOAD SENSING SYSTEM**

The Load sensing system is designed to meet the requirements of PLd in accordance with ISO 13849-1:2015 as required by BS EN 280:2013+A1 2015

*1. The limits of the safety-related parts to the category selected and any fault exclusions;*

The load sensing system is always active. The sensing system utilises an input from a single load cell and converts that signal into two channel system utilising a main channel and a redundant channel. The actual cage load is determined, and in the case of an overload, the alarm will sound and the output signal is lost.

The loss of the output signal is converted into two separate signals, one of which is used to isolate Channel 1 output (EN) and the other to isolate the Channel 2 output. (ALM). **Proper maintenance and daily safety checks to be observed.**

On initial set-up the machine must be zero loaded to allow the 'Tare' function to register the no-load condition. A calibrated test load is then put into the cage to set the upper limit. Proper adherence to the zero set point and the correct test load must be taken to ensure the load sensing system is working correctly. **Reasonably foreseeable misuse**

*2. The limits of the SRP/CS and any fault exclusion, for which, when essential for maintaining the selected category or categories and safety performance, appropriate information (e.g. for modification, maintenance and repair) shall be given to ensure the continued justification of the fault exclusion(s);*

Do not alter, modify or disable in any way the controls, safety devices, interlocks or any other part of the machine.

Maintenance must only be carried on by appropriately trained and competent persons, who are conversant with all modes of operation, speeds and characteristics of this model.

*3. The effects of deviations from the specified performance on the safety function(s);*

If the load sensing system does not function as intended it is possible that the Niftylift may encounter overloads for which it is not rated.

If the Niftylift encounters loads beyond the rating as specified on the serial plate the product may occur instability.

If the product becomes unstable, damage to the Niftylift, other equipment and properties, injury or loss of life of the operator and surrounding persons may be a risk.

*4. Clear descriptions of the interfaces to the SRP/CS and protective devices;*

The load moment control system comprises of a primary device the “load sensor” and a PLC, and protective devices, for example solenoid operated Master dump valves.

If the load sensing system becomes disconnected, the alarm will sound and a clear indication of visual overload will be given at each operating position. The system will not re-set until the overload has been removed.

*5. Response time;*

The Load sensing system is always active, the application of an overload will be detected within four seconds to cater for transient loads and acceleration forces. The alarm and visual indication will continue to sound as long as the machine is overloaded.

*6. Operating limits (including environmental conditions);*

All components within the load sensing system are rated to the environmental conditions acceptable for the machine; see **Section 2.2**.

*7. Indications and alarms;*

The cage overload detection system will cause the klaxon to sound and will be indicated by the red warning light on the base and cage location.

*8. Muting and suspension of safety functions;*

In the case of the overload being detected the alarm can be silenced by removing the load. Suspension of the function will continue until the overload has been safely removed.

*9. Control modes;*

The load sensing system has no user controllable modes of operation, other than by use of the calibration tool.

*10. Maintenance; Maintenance check lists;*

Please refer to the service manual for maintenance information

*11. Ease of accessibility and replacing of internal parts;*

Replacement of parts should only be carried out by appropriately trained and competent persons.

If parts require replacement only replace the whole such as Load Sensor, PLC, PCB or Hydraulic valve block.

Do not attempt to open the load sensing PCB or replace components soldered to any PCB.

Do not attempt maintenance of hydraulic components i.e. replace seals or internal component.

Only Niftylift original and supplied parts shall be used.

*12. Means for easy and safe trouble shooting;*

To check the operation of the load sensor system

1. Power on the Niftylift and select the base control location.
2. Allow the power circuits to cycle and ensure the machine is ready for the command signal.
3. Press the base green button and observe that the machine is ready to function with no load in the cage. (Machine runs, pump flow is available for machine functions.)
4. Select the Cage control position and mount into the cage.

## **nifty** Height Rider/SP Series

---

### **Operating & Safety Instructions**

5. Enable the cage controls and then press the cage green button or foot switch to enable the machine functions. (Machine runs, pump flow is available for machine operation.)
6. Add sufficient load to the cage to exceed the safe working load. Observe that the cage overload system brings in the alarm and halts all machine movements.
7. Remove the overload to below the threshold for safe working load and observe that the cage load control automatically re-sets and restores all machine functions.
8. Power off the Niftylift.

*13. Information explaining the applications for use relevant to the category to which reference is made;*

Not applicable

*14. Checking test intervals where relevant.*

Check the operation of the load sensing system to be made at the beginning of every duty cycle.

## **B5 PLATFORM LEVELLING**

The Platform levelling system is made to the requirements of PLd in accordance with ISO 13849-1:2015 as required by BS EN 280:2013+A1 2015

*1.The limits of the safety-related parts to the category selected and any fault exclusions;*

The Platform levelling system is always active. The system utilises an input from the cage inclination sensor and compares the reading to the tilt sensor. If the cage is detected to be out of  $\pm 10^\circ$  from the level of the chassis, machine movement is prevented by shutting off the engine and electric motor controller.

*2.The limits of the SRP/CS and any fault exclusion, for which, when essential for maintaining the selected category or categories and safety performance, appropriate information (e.g. for modification, maintenance and repair) shall be given to ensure the continued justification of the fault exclusion(s);*

Maintenance must only be carried on by appropriately trained and competent persons.

*3.The effects of deviations from the specified performance on the safety function(s);*

If the levelling system of the product does not function as intended the angle of the cage may not be maintained.

If the angle of cage is not maintained there is an increased risk of ejection of tools and equipment from the cage.

In the event of the operator or other occupants of the cage not using the required safety equipment they may be ejected from the cage and serious injury or death may occur.

*4.Clear descriptions of the interfaces to the SRP/CS and protective devices;*

All components in this safety function all components are connected via the CAN bus. The cage inclination sensor is connected to the cage PLC, the tilt sensor is connected to the base PLC and both PLCs are connected together.

In normal operation when the luffing boom is elevated, the booms shall stay within  $5^\circ$  of the level of the chassis. The luffing angle sensor will detect the angle of the boom and whether the angle is changing. If the angle is changing the level

If any component of the levelling system become disconnected, the PLC will assume the worst case state of that component e.g. if the cage sensor becomes disconnected, the PLC will assume the cage is out of level.

*5.Response time*

The cage and chassis inclination sensors are continuously active, monitoring their respective angles.

The cage platform will never become more than  $\pm 10^\circ$  out of level with respect to the level of the chassis.

*6.Operating limits (including environmental conditions);*

All components within the platform levelling system are rated to the environmental conditions acceptable for the machine; see **Section 2.2**.

## **Operating & Safety Instructions**

### *7. Indications and alarms;*

There is a visual warning on the display screen if the levelling system registers a value outside +/- 5 degrees of the chassis angle. All drive and boom movement (except cage levelling) will cease.

If this value exceeds +/- 10 degrees, a visual warning will show ALL machine movement will cease.

### *8. Muting and suspension of safety functions;*

The levelling function can be suspended under any of the following conditions:

- 1) White button is activated.
- 2) Cage Control Panel is selected, booms are stowed and chassis inclination sensor is not calibrated.
- 3) Auxiliary control panel used

### *9. Control modes;*

The levelling system has two modes of operation

- 1) Normal movements of the luffing booms cause the system to constantly adjust the cage angle to keep it level.
- 2) Manual adjustment to account for drift of the system over time.

### *10. Maintenance; Maintenance check lists;*

Please refer to the service manual for maintenance information

### *11. Ease of accessibility and replacing of internal parts;*

Replacement of parts should only be carried out by appropriately trained and competent persons.

If parts require replacement only replace the whole components such as hoses, hydraulic cylinders or load holding and over centre valve.

Do not attempt maintenance of hydraulic components i.e. replace seals or internal component?

Only Niftylift original and supplied parts shall be used.

### *12. Means for easy and safe trouble shooting;*

Elevate the luffing booms and check that the cage remains level. If the cage does not remain level the system should be serviced by trained persons fully conversant with the function of the system.

### *13. Information explaining the applications for use relevant to the category to which reference is made;*

Not applicable

### *14. Checking test intervals where relevant.*

Check the operation of the cage levelling system to be made at the beginning of every duty cycle.

## **B6 PREVENT MOVEMENTS OF LOAD HOLDING CYLINDERS IN CASE OF PIPE FAILURE**

The load holding system is PL c in accordance with ISO 13849-1:2015 as required by BS EN 280:2013+A1 2015

*1.The limits of the safety-related parts to the category selected and any fault exclusions;*

The load holding system comprises of a load holding device mounted to the cylinder.

*2.The limits of the SRP/CS and any fault exclusion, for which, when essential for maintaining the selected category or categories and safety performance, appropriate information (e.g. for modification, maintenance and repair) shall be given to ensure the continued justification of the fault exclusion(s);*

Do not alter, modify or disable in any way the controls, safety devices, interlocks or any other part of the machine.

In the event of a hose failure ensure a recovery plan is in place that does not require the movement of the affected cylinder. A safe route of recovery might involve the replacement in-situ of the failed hose before further movement of the machine is possible.

Maintenance must only be carried on by appropriately trained and competent persons.

*3.The effects of deviations from the specified performance on the safety function(s);*

If the load holding system of the product does not function as intended, in the event of a pipe failing the booms may dramatically lose pressure and the angle of cage may not be maintained.

If the angle of cage is not maintained there is an increased risk of ejection of tools and equipment from the cage;

In the event of the operator or other occupants of the cage not using the required safety equipment they may be ejected from the cage and serious injury or death may occur.

There is a load holding device contained within the assembly of each load holding cylinder such that if a hose fails the cage position is maintained until the operator can be recovered from the cage.

*4.Clear descriptions of the interfaces to the SRP/CS and protective devices;*

The load holding system comprises of a pilot operated over centre valve on each load holding cylinder.

The opening of the load holding valve is dependent on the application of a pilot pressure in the descent line to bring the machine down. Excessive over pressure either by overload or thermal expansion can induce an over centre pilot descent until the excess pressure condition is removed.

*5.Response time*

The load holding system is a direct acting hydraulic system and the response time is near instantaneous.

**Operating & Safety Instructions**

*6. Operating limits (including environmental conditions);*

All components within the load holding system are rated to the environmental conditions acceptable for the machine; see **Section 2.2**.

*7. Indications and alarms;*

There are no indicators or alarms to show that the Niftylift load holding system is functioning.

*8. Muting and suspension of safety functions;*

It is not possible to suspend the operation of the load holding system.

*9. Control modes;*

The load holding system has two modes of operation

- 1) Normal movements of the booms cause the system to constantly adjust the cylinders to maintain machine position and load holding.
- 2) Manual adjustment to recover the machine under emergency conditions.

*10. Maintenance; Maintenance check lists;*

Please refer to the service manual for maintenance information

*11. Ease of accessibility and replacing of internal parts;*

Replacement of parts should only be carried out by appropriately trained and competent persons.

If parts require replacement only replace the whole components such as hoses, hydraulic cylinders or load holding and over centre valve.

Do not attempt maintenance of hydraulic components i.e. replace seals or internal component.

Only Niftylift original and supplied parts shall be used.

*12. Means for easy and safe trouble shooting;*

Not applicable

*13. Information explaining the applications for use relevant to the category to which reference is made;*

Not applicable

*14. Checking test intervals where relevant.*

Check the operation of the load holding system to be made at the beginning of every duty cycle.

## **B7 INTERLOCKING OF TRAVEL CONTROLS**

The interlocking of the travel controls is PLb in accordance with ISO 13849-1:2015 as required by BS EN 280:2013+A1 2015

*1. The limits of the safety-related parts to the category selected and any fault exclusions;*

The interlock to prevent simultaneous operation of the booms and travel controls consists of a PLC which checks all cage controls. If the PLC detects an input from both a drive and boom function simultaneously, it will enable drive and prevent booms movement. **Proper maintenance and daily safety checks to be observed.**

*2. The limits of the SRP/CS and any fault exclusion, for which, when essential for maintaining the selected category or categories and safety performance, appropriate information (e.g. for modification, maintenance and repair) shall be given to ensure the continued justification of the fault exclusion(s);*

Do not alter, modify or disable in any way the controls, safety devices, interlocks or any other part of the machine.

Maintenance must only be carried out by appropriately trained and competent persons, who are conversant with all modes of operation, speeds and characteristics of this model.

*3. The effects of deviations from the specified performance on the safety function(s);*

If the interlocking of the travel controls does not function as intended it is possible that the Niftylift may allow modes of operation that render it potentially dangerous.

If the controls do not remain independent in their operation, damage to the Niftylift, other equipment and properties, injury or loss of life of the operator and surrounding persons may be a risk.

*4. Clear descriptions of the interfaces to the SRP/CS and protective devices;*

The travel controls interlock is comprised of the boom paddles, drive joystick and PLC.

If any component was to become disconnected the machine would prevent all movement unless auxiliary power is used.

*5. Response time*

Loss of the boom functions is immediately after a drive or steer function is selected.

*6. Operating limits (including environmental conditions);*

All components within the travel control interlock system are rated to the environmental conditions acceptable for the machine; see **Section 2.2**

*7. Indications and alarms;*

None.

*8. Muting and suspension of safety functions;*

None.

*9. Control modes;*

Either drive or booms operation modes are available.

## **Operating & Safety Instructions**

### *10. Maintenance; Maintenance check lists;*

Normal maintenance

- Visual check of all levers including the mechanical links from the levers to the valve spools.
- Ensure the smooth and uninterrupted operation of Drive controls.
- Check the loss of functions for all boom movements with the machine drive functions are operated and held to one end of travel. No boom functions should be available if any drive function is operated. Repeat for drive, but when doing so, be aware of the possibility of the machine moving as the control functions are checked. This should be performed in a clear, open area.

### *11. Ease of accessibility and replacing of internal parts;*

Replacement of parts should only be carried out by appropriately trained and competent persons.

Only Niftylift original and supplied parts shall be used.

### *12. Means for easy and safe trouble shooting;*

To check the operation of the travel control interlock.

1. Power on the Niftylift and select the cage control location.
2. Allow the power circuits to cycle and ensure the machine is ready for the command signal.
3. Press the base green button and operate a boom function to raise.
4. At the same time, operate the trigger and steer the drive wheels in one direction or the other.
5. Observe that the boom control function is lost and does not return until the steer lever is released.
6. In a clear area, repeat for a drive forward/ drive backward lever function whilst operating a boom raise command.
7. Observe that the boom control function is lost and does not return until the drive lever is released.
8. Power off the Niftylift.

### *13. Information explaining the applications for use relevant to the category to which reference is made;*

Not applicable

### *14. Checking test intervals where relevant.*

Check the operation of the travel control interlock to be made at every service interval.

## **B8 EMERGENCY STOP SYSTEM**

The Emergency stop system is PLC in accordance with BS EN ISO 13849:2015 as required by BS EN 280:2013+A1 2015.

*1. The limits of the safety-related parts to the category selected and any fault exclusions;*

Emergency stops are situated at both the cage and base control panels. They consist of normally open and normally closed contacts that are mechanically linked. The dual channel architecture utilises antivalence to facilitate error checking and diagnostics. If an E-stop is pushed, all machine movement is stopped and further movement is prevented.

If the E-Stop at the work platform is pressed, then the ground operator shall be allowed to override the E-stop by switching to base controls and using normal machine operation to lower the booms. If the operator in the cage disapproves of the boom movement or intentions of the ground control operator, then the cage E-Stop being released and pressed again shall stop all machine motion. The base E-stop, if pressed, can also be overridden by the cage controls if the key switch is selected to cage.

### **Reasonably foreseeable misuse**

*2. The limits of the SRP/CS and any fault exclusion, for which, when essential for maintaining the selected category or categories and safety performance, appropriate information (e.g. for modification, maintenance and repair) shall be given to ensure the continued justification of the fault exclusion(s);*

Do not alter, modify or disable in any way the controls, safety devices, interlocks or any other part of the machine.

Maintenance must only be carried on by appropriately trained and competent persons, who are conversant with all modes of operation, speeds and characteristics of this model.

*3. The effects of deviations from the specified performance on the safety function(s);*

If the Emergency stop system does not function as intended it is possible that the Niftylift may function when the E-stop is pressed.

If the product moves unexpectedly, or does not prevent movement when an emergency arises, damage to the Niftylift, other equipment and properties, injury or loss of life of the operator and surrounding persons may be a risk.

*4. Clear descriptions of the interfaces to the SRP/CS and protective devices;*

The Emergency stop system comprises of a two emergency stop buttons, a PLC and two relays that shut off the engine PLC and electric motor controller.

If the E-stop system is activated the system will not re-set until the button has been released.

*5. Response time;*

Operating the emergency stop is immediate

*6. Operating limits (including environmental conditions);*

All components within the emergency stop systems are rated to the environmental conditions acceptable for the machine; see **Section 2.2**.

## **Operating & Safety Instructions**

### *7. Indications and alarms;*

When activated the emergency stop button remain visually in an operated position. In addition, an image will appear on the display screen showing which E-stop has been activated along with an audible sound.

### *8. Muting and suspension of safety functions;*

If the E-stop button in the cage is activated, the operator at the base may override this E-stop by changing the control location to the base using the key switch located at the base. The cage operator may then release the E-stop and operate it again to disable drive and boom functions. In addition if the E-stop button at the base has been activated this can be overridden by turning the base key switch to cage and operating the green button or footswitch.

### *9. Control modes;*

The emergency stop system has no user controllable modes of operation.

### *10. Maintenance; Maintenance check lists;*

Please refer to the service manual for maintenance information

### *11. Ease of accessibility and replacing of internal parts;*

Replacement of parts should only be carried out by appropriately trained and competent persons.

If parts require replacement only replace the complete item such as the contact blocks, PLC, or Hydraulic valve block.

Do not attempt to open the main base PLC or replace components soldered to any PCB.

Do not attempt maintenance of hydraulic components i.e. replace seals or internal component.

Only Niftylift original and supplied parts shall be used.

### *12. Means for easy and safe trouble shooting;*

To check the operation of the emergency stop system

1. Power on the Niftylift and select the base control location.
2. Allow the power circuits to cycle and ensure the machine is ready for the command signal.
3. Press the base green button and observe that the machine is ready to function with no load in the cage. (Machine runs, pump flow is available for machine functions.)
4. Select the Cage control position and mount into the cage.
5. Enable the cage controls and then press the cage green button or foot switch to enable the machine functions. (Machine runs, pump flow is available for machine operation.)
6. Press the cage emergency stop button. Press the green button or foot switch and observe that machine movements have been halted
7. Release the cage emergency stop button, switch the controls to the base and repeat for the base emergency stop button.
8. Power off the Niftylift.

### *13. Information explaining the applications for use relevant to the category to which reference is made;*

Not applicable

14. *Checking test intervals where relevant.*

Check the operation of the emergency stop system to be made at the beginning of every duty cycle.

## **B9 SiOPS**

The Sustained Involuntary Operation Prevention System (SiOPS) is designed to meet the requirements of PLd in accordance with BS EN ISO 13849-1:2015.

*1. The limits of the safety-related parts to the category selected and any fault exclusions;*

The SiOPS is always active. The input is dual-channel, utilising four magnetic reed switches connected to the underside of the cage console. If the console is pushed down with sufficient force on either side, the reed switches will move away from their magnets and make or break their respective circuits. The PLC will detect the change in state and prevent all further machine movement.

**Proper maintenance and daily safety checks to be observed.**

*2. The limits of the SRP/CS and any fault exclusion, for which, when essential for maintaining the selected category or categories and safety performance, appropriate information (e.g. for modification, maintenance and repair) shall be given to ensure the continued justification of the fault exclusion(s);*

Do not alter, modify or disable in any way the controls, safety devices, interlocks or any other part of the machine.

Maintenance must only be carried on by appropriately trained and competent persons, who are conversant with all modes of operation, speeds and characteristics of this model.

*3. The effects of deviations from the specified performance on the safety function(s);*

If the SiOPS does not function as intended it is possible that the operator or operators may, if pressed against the cage console, involuntarily operate the controls entrapping themselves further.

If the operator or operators experience sustained loading they may be subject to severe injury or loss of life.

*4. Clear descriptions of the interfaces to the SRP/CS and protective devices;*

The SiOPS comprises of a primary device the “console switches” and a PLC, and two safety relays that cut power to the engine PLC and electric motor controller.

If SiOPS is triggered the machine movement will stop and further movement prevented other than away from the hazard.

*5. Response time;*

The SiOPS system is always active when the machine is in use.

*6. Operating limits (including environmental conditions);*

All components within the SiOPS are rated to the environmental conditions acceptable for the machine; see **Section 2.2**.

*7. Indications and alarms;*

The action of the SiOPS will cause the klaxon to sound and will be indicated by the blue warning light located on the cage. In addition a SiOPS warning symbol will appear on the display screen.

## **Operating & Safety Instructions**

---

### *8. Muting and suspension of safety functions;*

In the case of the SiOPS being detected the alarm can be silenced by releasing the load from the front of the cage console. Suspension of the function will continue until the green button is released.

### *9. Control modes;*

The SiOPS system has no user controllable modes of operation, other than when an operator activates the SiOPS system.

### *10. Maintenance; Maintenance checklists;*

Please refer to the service manual for maintenance information

### *11. Ease of accessibility and replacing of internal parts;*

Replacement of parts should only be carried out by appropriately trained and competent persons.

If parts require replacement only replace the whole such as input switch, PLC, PCB. Do not attempt to open the PLC or replace components soldered to any PCB.

Do not attempt maintenance of hydraulic components i.e. replace seals or internal component.

Only Niftylift original and supplied parts shall be used.

### *12. Means for easy and safe trouble shooting;*

To check the operation of the SiOPS system

1. Power on the Niftylift and select the cage control station.
2. Allow the power circuits to cycle and ensure the machine is ready for the command signal.
3. Press the cage foot switch or cage green button and operate the machine functions from the cage. (Machine runs, pump flow is available for machine functions, drive functions)
4. Whilst operating the machine from the cage foot switch or cage green button, apply pressure to the cage console and observe that the functions stop operating. With the pressure being applied to the cage console, both the cage and the base green buttons should flash green.
5. Apply pressure to the cage console for 15 seconds and maintain pressure. Observe that the klaxon sounds and the blue warning light flashes.
6. Maintain pressure on the console and check that the machine boom and drive functions are not available. Maintain pressure on the cage console and release the cage green button. Re-press the cage green button to check the SiOPS override functionality from the cage controls. Machine functions will return and drive should remain disabled.
7. Press base green button while maintaining pressure on the cage console, to check the SiOPS override functionality from the base controls. Repeat steps 4, 5 and 6 with a second operator, select the base control station. . Machine functions will return (Machine runs, pump flow is available for machine operation.)
8. Remove the pressure from the cage console and observe that the flashing green buttons, the klaxon and the blue warning light should stop. Normal operation of booms and drive will be returned.
9. Power off the Niftylift.

### *13. Information explaining the applications for use relevant to the category to which reference is made;*

Not applicable

*14. Checking test intervals where relevant.*

Check the operation of the SiOPS system to be made at the beginning of every duty cycle.

*15. Proof testing*

This two channel system must be proof tested to identify unrevealed failures every six months by a competent person with appropriate safety function experience.

## **Operating & Safety Instructions**

### **B10 AUXILIARY OVERRIDE SYSTEM**

The auxiliary override system is designed to meet the requirements of PLd in accordance with BS EN ISO 13849-1:2015.

*1. The limits of the safety-related parts to the category selected and any fault exclusions;*

The auxiliary system activates when the white button is pushed at the cage or base control positions or the auxiliary keyswitch is used at the base when there is not power. The white buttons utilise a dual-channel architecture and can be used at any time when the machine is in use. When pushed the white buttons will energise the auxiliary pump. The auxiliary keyswitch can be used when the machine has no power to directly energise the auxiliary pump.

The auxiliary pump will override all safety functions e.g. load sensing, levelling, tilt, SiOPS and E-stops and will only enable one boom function at a time and will not enable drive.

**Proper maintenance and daily safety checks to be observed.**

*2. The limits of the SRP/CS and any fault exclusion, for which, when essential for maintaining the selected category or categories and safety performance, appropriate information (e.g. for modification, maintenance and repair) shall be given to ensure the continued justification of the fault exclusion(s);*

Do not alter, modify or disable in any way the controls, safety devices, interlocks or any other part of the machine.

Maintenance must only be carried on by appropriately trained and competent persons, who are conversant with all modes of operation, speeds and characteristics of this model.

*3. The effects of deviations from the specified performance on the safety function(s);*

If the auxiliary override system does not function as intended it is possible that the operator or operators may be stranded if a safety function triggers and cannot be reversed.

It is dangerous for the operators to be stranded with no control of the machine for any given period of time.

*4. Clear descriptions of the interfaces to the SRP/CS and protective devices;*

The auxiliary system comprises of two, dual channel white buttons, a dual-channel keyswitch, the PLC and two relays that shut off power to the engine PLC and electric motor controller.

If the white button is pressed and the auxiliary system is triggered the auxiliary pump will energise and machine boom movement will be available, allowing only one boom movement at a time.

*5. Response time;*

The Auxiliary Override system is always available when the machine is in use.

*6. Operating limits (including environmental conditions);*

All components within the Auxiliary Override are rated to the environmental conditions acceptable for the machine; see **Section 2.2**.

*7. Indications and alarms;*

Not applicable

*8. Muting and suspension of safety functions;*

Not applicable

*9. Control modes;*

The Auxiliary Override system has no user controllable modes of operation, other than when an operator activates the system.

*10. Maintenance; Maintenance checklists;*

Please refer to the service manual for maintenance information.

*11. Ease of accessibility and replacing of internal parts;*

Replacement of parts should only be carried out by appropriately trained and competent persons.

If parts require replacement only replace the whole such as input switch, PLC, PCB. Do not attempt to open the PLC or replace components soldered to any PCB.

Do not attempt maintenance of hydraulic components i.e. replace seals or internal component.

Only Niftylift original and supplied parts shall be used.

*12. Means for easy and safe trouble shooting;*

To check the operation of the Auxiliary Override system

1. Power on the Niftylift and select the cage control station.
2. Allow the power circuits to cycle and ensure the machine is ready for the command signal.
3. Press the cage foot switch or cage green button and operate the machine functions from the cage slightly raising the platform. (Machine runs, pump flow is available for machine functions, drive functions)
4. Press and hold the cage white button and operate the machine functions from the cage. (Machine runs, pump flow is available for machine boom functions)
5. Power off the Niftylift.

*13. Information explaining the applications for use relevant to the category to which reference is made;*

Not applicable.

*14. Checking test intervals where relevant.*

Check the operation of the auxiliary override system at the beginning of every duty cycle.

*15. Proof testing*

This system must be proof tested to identify unrevealed failures every six months by a competent person with appropriate safety function experience.

***niftylift***