

Optimum energy efficiency

Efficiency and drive&liftPLUS performance packages

Lateral battery exchange

Ergonomic and easily adjustable operating concept

Ergonomic workstation



EFG 425k/425/430k/430/S30

Electric four-wheel counterbalanced fork lift trucks (2,500/3,000 kg)

Our Series 4 electric four-wheel counterbalanced fork lift trucks with capacities up to 3000 kg are ideal for a wide range of indoor and outdoor applications, particularly when using attachments. Moreover, our PureEnergy technology concept allows them to achieve best possible energy and cost efficiency combined with maximum performance.

By using the most advanced 3-phase AC technology in combination with our own manufactured electronic controller as well as an efficient and compact hydraulic unit, we have been able to significantly reduce energy consumption – while simultaneously increasing throughput. Measurements as per the VDI cycle document: At maximum throughput, our EFG Series 4 consumes up to 10 % less energy than comparable competitor models.

A choice of configuration packages with variable travel/lift speeds from the Efficiency and drive&liftPLUS modules solves your transport and stacking operations with maximum energy efficiency.

The infinitely adjustable steering column and armrest allow for adjustment to suit all operator sizes. Individual modification of the controls is very easy thanks to the single-point adaptation via 2 adjustable axes.

Our EFG Series 4 offers the best visibility in the market thanks to an expanded field of vision. We achieve this thanks to our compact mast, compact profile nesting, an optimised chain and hose guide as well as 2 viewing windows in the cross member.

The truck contour is closed on the operator's right side. This guarantees maximum rigidity and stability for the overall design and creates a number of storage options, e.g. for papers and a smartphone.

Proven concepts for demanding yet energy and cost-saving applications, make the Series 4 EFG trucks universally suitable for indoor and outdoor operation.



HONEST, RELIABLE & REACTIVE
SOLUTIONS FOR WORKING AT HEIGHT



CONTACT US

0800 865 4455

info@hiresafesolutions.com

www.hiresafesolutions.com



EFG 425k/425/430k/430/S30

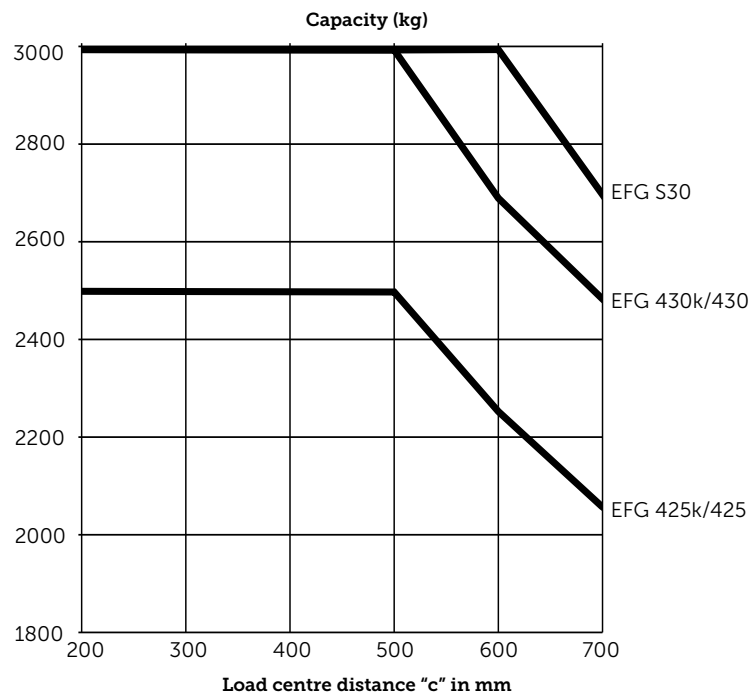
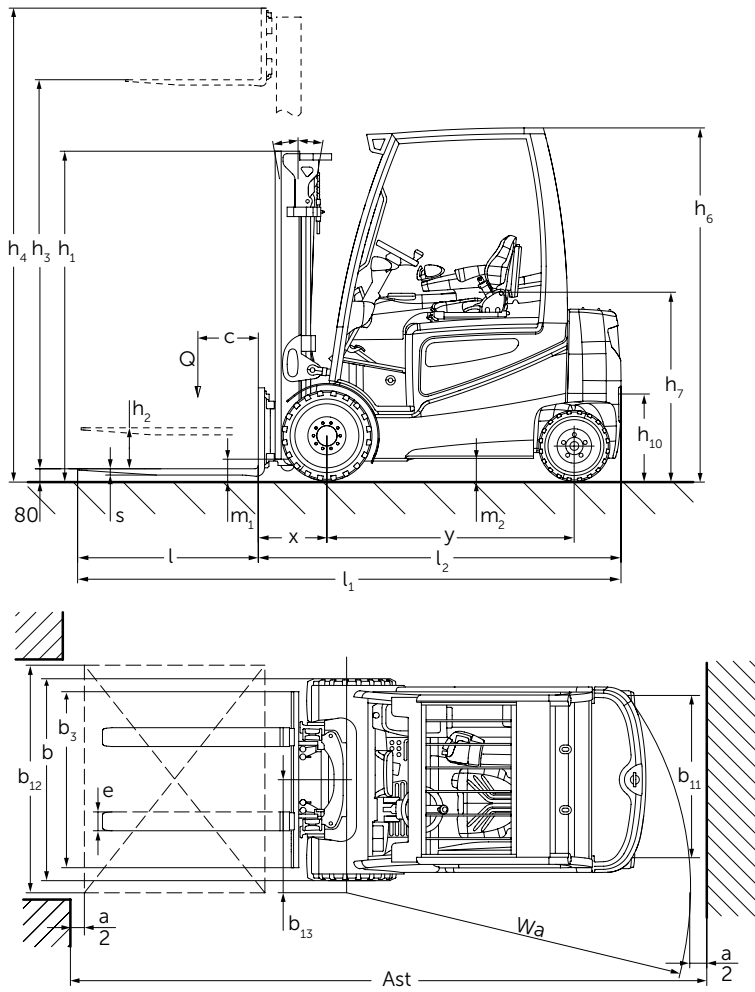

EFG 425k/425/430k/430/S30

Standard mast designs EFG 425k/425/430k/430/S30								
	Lift h_3	Lowered mast height h_1		Free lift h_2		Extended mast height h_4		Mast tilt forward/back α/β (°)
	(mm)	(mm)		(mm)		(mm)		
		EFG 425k / 425	EFG 430k / 430 / S30	EFG 425k / 425	EFG 430k / 430 / S30	EFG 425k / 425	EFG 430k / 430 / S30	
Duplex ZT	2900	2125	2122	150	150	3655	3657	6/8
	3100	2225	2222	150	150	3855	3857	6/8
	3300	2325	2322	150	150	4055	4057	6/8
	3500	2425	2422	150	150	4255	4257	6/8
	3700	2525	2522	150	150	4455	4457	6/8
	4000	2675	2672	150	150	4755	4757	6/8
	4300	2875	2872	150	150	5055	5057	6/8
Duplex ZZ	4500	2975	2972	150	150	5255	5257	6/8
	3100	2190	2187	1600	1450	3690	3837	6/8
	3300	2290	2287	1700	1550	3890	4037	6/8
	3500	2390	2387	1800	1650	4090	4237	6/8
	3700	2490	2487	1900	1750	4290	4437	6/8
Triplex DZ	4000	2640	2637	2050	1900	4590	4737	6/8
	4400	2090	2087	1500	1350	4990	5137	6/8
	4700	2190	2187	1600	1450	5290	5437	6/5.5
	5000	2290	2287	1700	1550	5590	5737	6/5.5
	5500	2490	2487	1900	1750	6090	6237	6/5.5
	6000	2690	2687	2100	1950	6590	6737	6/5.5
	6500	2890	2887	2300	2150	7090	7237	6/3
	7000	3090	3087	2500	2350	7590	7737	6/3
	7500	3290	3287	2700	2550	8090	8237	6/3



HONEST, RELIABLE & REACTIVE
SOLUTIONS FOR WORKING AT HEIGHT



CONTACT US

- 0800 865 4455
- info@hiresafesolutions.com
- www.hiresafesolutions.com



Technical data in line with VDI 2198

		Jungheinrich					
		EFG 425k	EFG 425	EFG 430k			
Identification	1.1	Manufacturer (abbreviation)		Jungheinrich			
	1.2	Model					
	1.3	Drive		Electric			
	1.4	Manual, pedestrian, stand-on, seated, order picker operation		seat			
	1.5	Load capacity/rated load	Q t	2.5	2.5	3	
	1.6	Load centre distance	c mm	500			
	1.8	Load distance	x mm	425	425 ¹⁾	447	
	1.9	Wheelbase	y mm	1,575	1,720	1,575	
	Weights	2.1.1	Net weight incl. battery (see row 6.5)		kg	4,770	4,680
2.2		Axle loading, laden front/rear		kg	6,440 / 830	6,590 / 590	7,360 / 910
2.3		Axle loading, unladen front/rear		kg	2,450 / 2,320	2,720 / 1,960	2,530 / 2,730
Wheels / frame	3.1	Tyres		SE			
	3.2	Tyre size, front		225 / 75-10			
	3.3	Tyre size, rear		180 / 70-8			
	3.5	Wheels, number front/rear (x = driven wheels)		2X / 2			
	3.6	Tread width, front	b ₁₀ mm	990	990	950	
	3.7	Tread width, rear	b ₁₁ mm	940			
	Basic dimensions	4.1	Tilt of mast/fork carriage forward/backward		α/β °	6/8	
4.2		Mast height (lowered)		h ₁ mm	2,225	2,225	2,222
4.3		Free lift		h ₂ mm	150		
4.4		Lift		h ₃ mm	3,100		
4.5		Extended mast height		h ₄ mm	3,855	3,855	3,857
4.7		Height of overhead guard		h ₆ mm	2,240		
4.8		Seat height/standing height		h ₇ mm	1,190		
4.12		Coupling height		h ₁₀ mm	385		
4.12.1		2. Coupling height		mm	540		
4.19.4		Total length including fork length		l ₁ mm	3,446	3,591	3,467
4.20		Length to face of forks		l ₂ mm	2,296	2,441	2,317
4.21		Overall width		b ₁ /b ₂ mm	1,198		
4.22		Fork dimensions		s/e/l mm	40 / 120 / 1,150	40 / 120 / 1,150	45 / 125 / 1,150
4.23		Fork carriage ISO 2328, class/type A, B			2A	2A	3A
4.24		Fork carriage width		b ₃ mm	1,120		
4.31		Floor clearance with load under mast		m ₁ mm	117		
4.32		Ground clearance, centre of wheelbase		m ₂ mm	135		
4.33		Aisle width for pallets 1000 x 1200 crossways		Ast mm	3,625	3,775	3,647
4.34	Aisle width for pallets 800 x 1200 lengthways		Ast mm	3,825	3,975	3,847	
4.35	Turning radius		W _a mm	2,000	2,150	2,000	
4.36	Smallest turning radius		b ₁₃ mm	600			
Performance data	5.1	Travel speed, laden/unladen		km/h	19 / 20 ²⁾		
	5.2	Lift speed, laden/unladen		m/s	0.48 / 0.6 ³⁾	0.48 / 0.6 ³⁾	0.43 / 0.6 ³⁾
	5.3	Lowering speed, laden/unladen		m/s	0.58 / 0.58 ³⁾		
	5.5	Drawbar pull, laden/unladen		N	5,100 / 5,600 ³⁾	4,900 / 5,500 ³⁾	5,000 / 5,800 ³⁾
	5.6	Max. drawbar pull, laden/unladen		N	16,000 / 16,300 ³⁾	16,000 / 16,300 ³⁾	15,700 / 16,000 ³⁾
	5.7	Gradeability, laden/unladen		%	10 / 16 ³⁾	10 / 16 ³⁾	9 / 15 ³⁾
	5.8	Max. gradeability, laden/unladen		%	19 / 27 ³⁾	19 / 27 ³⁾	17 / 25 ³⁾
	5.9.1	Acceleration time, laden/unladen (to 10 m)		S	4.5 / 4 ³⁾		
	5.10	Service brake			mechanical		
	Electrics	6.1	Drive motor, output S2 60 min.		kW	15.0 ³⁾	
6.2		Lift motor, output at S3 15%		kW	22.0 ³⁾		
6.3		Battery as per DIN 43531/35/36 A, B, C, no			A 43536		
6.4		Battery voltage/nominal capacity K5		V/Ah	80 / 620	80 / 775	80 / 620
6.5		Battery weight		kg	1,540	1,863	1,540
		Battery dimensions L/W/H		mm	1,028 / 711 / 784	1,028 / 855 / 784	1,028 / 711 / 784
6.6		Energy consumption as per EN 16796		kWh/h	6 ²⁾³⁾	6 ²⁾³⁾	6.9 ²⁾³⁾
		CO ₂ Equivalent as per EN 16796		kg/h	3.2	3.2	3.7
6.7	Throughput		t/h	196 ³⁾	196 ³⁾	225 ³⁾	
6.8	Energy consumption at max. throughput		kWh/h	7 ⁴⁾	7 ⁴⁾	7.2 ⁴⁾	
Misc.	8.1	Type of drive control			Impuls/AC		
	8.2	Working pressure for attachments		bar	200		
	8.3	Oil flow for attachments		l/min	25		
	8.4	Sound pressure level at operator's ear as per EN 12053		dB (A)	70		
	8.5	Trailer coupling, model/type DIN			DIN 15170-H		

¹⁾ +10 mm with DZ mast

²⁾ 60 VDI work cycles/h

³⁾ With drive&liftPLUS options package

⁴⁾ With Efficiency options package

In accordance with VDI Guideline 2198, this data sheet provides details of the standard truck only. Non-standard tyres, different masts, optional equipment, etc. may result in different values.



Technical data in line with VDI 2198

				Jungheinrich		
				EFG 430	EFG S30	
Identification	1.1	Manufacturer (abbreviation)		Jungheinrich		
	1.2	Model				
	1.3	Drive		Electric		
	1.4	Manual, pedestrian, stand-on, seated, order picker operation		seat		
	1.5	Load capacity/rated load	Q	t	3	
	1.6	Load centre distance	c	mm	500	600
	1.8	Load distance	x	mm	447	452
	1.9	Wheelbase	y	mm	1,720	
	Weights	2.1.1	Net weight incl. battery (see row 6.5)		5,080	5,330
2.2		Axle loading, laden front/rear		7,450 / 630	7,620 / 710	
2.3		Axle loading, unladen front/rear		2,770 / 2,310	2,780 / 2,550	
Wheels / frame	3.1	Tyres		SE		
	3.2	Tyre size, front		250 / 60-12	315 / 45-12	
	3.3	Tyre size, rear		180 / 70-8	200 / 50-10	
	3.5	Wheels, number front/rear (x = driven wheels)		2X / 2		
	3.6	Tread width, front	b ₁₀	mm	950	1,000
	3.7	Tread width, rear	b ₁₁	mm	940	
	Basic dimensions	4.1	Tilt of mast/fork carriage forward/backward		α/β °	
4.2		Mast height (lowered)		h ₁ mm		
4.3		Free lift		h ₂ mm		
4.4		Lift		h ₃ mm		
4.5		Extended mast height		h ₄ mm		
4.7		Height of overhead guard		h ₆ mm		
4.8		Seat height/standing height		h ₇ mm		
4.12		Coupling height		h ₁₀ mm		
4.12.1		2. Coupling height		mm		
4.19.4		Total length including fork length		l ₁	mm	3,612
4.20		Length to face of forks		l ₂	mm	2,462
4.21		Overall width		b ₁ /b ₂	mm	1,198
4.22		Fork dimensions		s/e/l	mm	45 / 125 / 1,150
4.23		Fork carriage ISO 2328, class/type A, B		3A		
4.24		Fork carriage width		b ₃	mm	1,120
4.31		Floor clearance with load under mast		m ₁	mm	117
4.32	Ground clearance, centre of wheelbase		m ₂	mm	135	
4.33	Aisle width for pallets 1000 x 1200 crossways		Ast	mm	3,797	
4.34	Aisle width for pallets 800 x 1200 lengthways		Ast	mm	3,997	
4.35	Turning radius		W _a	mm	2,150	
4.36	Smallest turning radius		b ₁₃	mm	600	
Performance data	5.1	Travel speed, laden/unladen		km/h		
	5.2	Lift speed, laden/unladen		m/s		
	5.3	Lowering speed, laden/unladen		m/s		
	5.5	Drawbar pull, laden/unladen		N		
	5.6	Max. drawbar pull, laden/unladen		N		
	5.7	Gradeability, laden/unladen		9 / 15 ²⁾	8 / 14 ²⁾	
	5.8	Max. gradeability, laden/unladen		18 / 26 ²⁾	17 / 25 ²⁾	
	5.9.1	Acceleration time, laden/unladen (to 10 m)		S		
	5.10	Service brake		mechanical		
	Electrics	6.1	Drive motor, output S2 60 min.		kW	
6.2		Lift motor, output at S3 15%		kW		
6.3		Battery as per DIN 43531/35/36 A, B, C, no		A 43536		
6.4		Battery voltage/nominal capacity K5		V/Ah		
6.5		Battery weight		kg		
		Battery dimensions L/W/H		mm		
6.6		Energy consumption as per EN 16796		6.9 ¹⁾²⁾	7.8 ¹⁾²⁾	
6.7		CO ₂ Equivalent as per EN 16796		3.7	4.2	
6.8	Throughput		225 ²⁾	220 ²⁾		
6.8	Energy consumption at max. throughput		7.2 ³⁾	8.1 ³⁾		
Misc.	8.1	Type of drive control		Impuls/AC		
	8.2	Working pressure for attachments		bar		
	8.3	Oil flow for attachments		l/min		
	8.4	Sound pressure level at operator's ear as per EN 12053		dB (A)		
	8.5	Trailer coupling, model/type DIN		DIN 15170-H		

¹⁾ 60 VDI work cycles/h

²⁾ With drive&liftPLUS options package

³⁾ With Efficiency options package

In accordance with VDI Guideline 2198, this data sheet provides details of the standard truck only. Non-standard tyres, different masts, optional equipment, etc. may result in different values.



EFG 425k/425/430k/430/S30



HONEST, RELIABLE & REACTIVE
SOLUTIONS FOR WORKING AT HEIGHT

CONTACT US

- 0800 865 4455
- info@hiresafesolutions.com
- www.hiresafesolutions.com



Benefit from the advantages



Lateral battery exchange



duoPILOT



soloPILOT



multiPILOT

PureEnergy

Our PureEnergy technology concept enables you to achieve optimum energy efficiency coupled with maximum throughput:

- Advanced 3-phase AC technology.
- Compact controller.
- Compact hydraulic unit.
- Needs-oriented control of the hydraulics/motors.

Options packages

The right truck for every customer application thanks to individually selectable packages:

- Efficiency package with curveCONTROL.
- drive&liftPLUS package with greater travel/lift speeds.

Parameter steering

Electric steering with dynamic response depending on the travel program selected:

- Minimises unnecessary steering changes.
- Slim steering column creates more legroom.
- Improved energy efficiency.
- Optimised throughput.

Lateral battery exchange

- Universal battery exchange system for all 48 V and 80 V trucks.
- Simple, rapid and reliable exchange system.

Ergonomic and easily adjustable operating concept

- Selection from 5 freely adjustable travel programs.
- Stepless single-point adjustment of the armrest and steering column in 2 axes.
- A choice of 3 different controls.
- Adjustable lever and controls angle.
- Single or double pedal operation.

Ergonomic workstation

The ergonomics of the operator's workstation guarantee relaxed, fatigue-free work:

- Low, highlighted entry step with level foot-well.
- Slim steering column for maximum knee and legroom.
- High-resolution, contrast-rich, full-colour TFT display with intuitive user interface.
- Compact nested profile package with excellent visibility.
- Unobstructed view thanks to special overhead guard design, optimised chain and hose configuration.
- Operator-oriented storage concept for intuitive operation.
- Large, adjustable armrest with different upholstery fabrics and spacious storage compartment.
- External power supply via optional USB port.
- Low vibrations as the cab floats on special mountings.

Safety

Comprehensive safety equipment for high drive dynamics and performance:

- Reduction of travel speed when cornering due to curveCONTROL.
- No uncontrolled roll-back on ramps or inclines due to automatic wheel stop (optional).
- Excellent stability due to extremely low centre of gravity and high pivot steer axle.

Additional safety for the operator, truck and load due to a range of optional operator assistance systems:

- accessCONTROL: Access control system which only unlocks the truck once a sequence of safety checks has been completed:
 1. Valid access code.
 2. Closed seat switch.
 3. Seatbelt is secured.
- driveCONTROL: Speed control, which automatically reduces the speed both when cornering and from a defined lift height.
- liftCONTROL: Lift speed control, which reduces the travel speed as well as the tilt speed of the mast beginning at a defined lift height. The tilt angle is shown on a separate display.

Lithium-ion technology

- High degree of availability thanks to extremely short charging times.
- No battery exchange required.
- Cost savings due to longer service life and low maintenance compared with lead-acid batteries.
- No charging rooms and ventilation required as there is no build up of gas.
- Longer service life with 5-year Jungheinrich guarantee.

