

Model TOUCAN 8E

MAST BOOM LIFTS

Performance

- Working height 8.20 m
- Working outreach (standard platform) 2.65 m
- Up and over height 5.08 m
- Swing (not continuous) 345°
- Platform capacity ¹ 200 kg
- Jib - overall length 1.17 m
- Jib - range of articulation 112° (+45°/-67°)
 - A. Platform size standard platform (L x W) 0.85 x 0.92 m
 - B. Overall width 0.99 m
 - C. Tailswing 17 cm
 - D. Stowed height 1.99 m
 - E. Overall length (standard platform) 2.10 m
 - F. Wheelbase 1.20 m
 - G. Ground clearance 10 cm
- Machine weight - standard platform ² 2,100 kg
- Maximum ground bearing pressure 17,2 kg/cm²
- Drive speed - lowered 5.5 km/h
- Turning radius (outside) 1.99 m
- Turning radius (inside) 0.55 m
- Gradeability 25%

¹ Capacity shown is maximum two persons indoor and outdoor (12.5 m/s wind speed)

² Certain options or country standards may increase weight and/or dimensions.



Reach Diagram

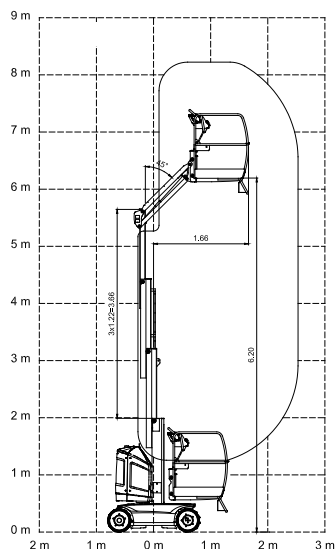

Dimensions

