

Model TOUCAN 10E

MAST BOOM LIFTS

JLG®

MORE ECONOMIC

- Electric power for zero emissions and near-silent running indoors.

MORE PRODUCTIVE

- No waiting with immediate-response AC drive motors for greater torque and efficiency.

MORE ACCESS

- Get into more places with compact dimensions and precise control system.

SMART DESIGN

- Extended reach and up-and-over height with heavy duty forklift-style mast and versatile articulating jib.



Standard Features

- 0.90 m x 0.70 m (L x W) steel platform
- Slide bar rear entry
- Full proportional drive and slew joystick control with integral thumb steer switch
- Mini joysticks provide proportional mast and jib lift/lower functions
- 1.60 m articulating jib
- Load sensing system
- AC power cable to platform
- Large tool tray
- Two wheel direct electric drive
- Brushless AC drive motors
- Auto power save when idle
- Low charge function cut-out
- On-board diagnostics with integral display
- Automatic rear wheel brakes
- Sculptured polyester hoods
- Heavy duty steel roller mast with 345° rotation
- Chain slack detection system
- 2,5 degree tilt alarm and indicator light
- Passive pothole protection system
- 0.99 m wide frame
- Lifting /tie down rings
- Ground control selector switch with key lock
- Battery discharge indicator
- Hour meter
- Horn
- Drive orientation system
- Lanyard anchor points
- Xenon strobe light
- Manual descent system

Standard Specifications

- | | |
|-----------------------------|----------------|
| • Tyres (non-marking solid) | 406 x 125 mm |
| • Electrical system | 24V DC |
| • Batteries (AGM) | 24V - 260 A.h |
| • Charger | 24V - 27A |
| • Drive motors | Dual AC motors |
| • Electrical (pump) motor | 3kW 24V DC |
| • Hydraulic system | 7.5 L |

Accessories & Options

- 8 mm air line to platform
- Acoustic motion alarm
- Food Compatible Hydraulic Oil
- Low Temperature Hydraulic Oil
- Platform Power Plug & Socket ¹
- Platform work lights 70W
- Synthetic Biodegradable Hydraulic Oil
- Special paint colour



Model TOUCAN 10E

MAST BOOM LIFTS

Performance

- Working height 10.10 m
- Working outreach (standard platform) 3.38 m
- Up and over height 6.51 m
- Swing (not continuous) 345°
- Platform capacity ¹ 200kg
- Jib - overall length 1.60 m
- Jib - range of articulation 126° (+65°/-61°)
 - A. Platform size standard platform (L x W) 0.70 x 0.90 m
 - B. Overall width 0.99 m
 - C. Tailswing 12 cm
 - D. Stowed height 1.99 m
 - E. Overall length (standard platform) 2.82 m
 - F. Wheelbase 1.20 m
 - G. Ground clearance 10 cm
- Machine weight - standard platform ² 2,980 kg
- Maximum ground bearing pressure 21.5 kg/cm²
- Drive speed - lowered 5.5 km/h
- Turning radius (outside) 1.99 m
- Turning radius (inside) 0.55 m
- Gradeability 25%

¹ Capacity shown is maximum two persons indoor and outdoor (12.5 m/s wind speed)

² Certain options or country standards may increase weight and/or dimensions.



Reach Diagram

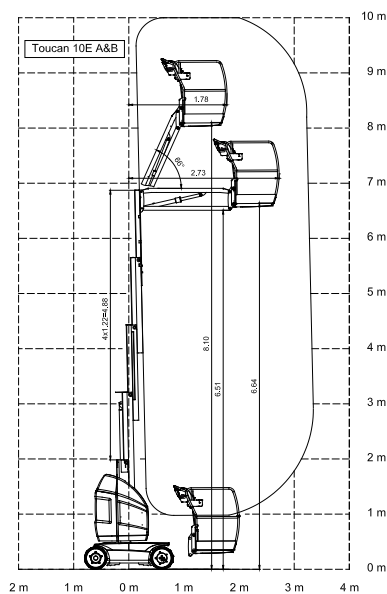

Dimensions

