



An Oshkosh Corporation Company

Operation and Safety Manual

Original Instructions - Keep this manual with the machine at all times.

TOUCAN 8E
TOUCAN 10E

CE AS

31210364

November 12, 2019

English - Operation & Safety

FOREWORD

This manual is a very important tool! Keep it with the machine at all times.

The purpose of this manual is to provide owners, users, operators, lessors, and lessees with the precautions and operating procedures essential for the safe and proper machine operation for its intended purpose.

Due to continuous product improvements, JLG Industries, Inc. reserves the right to make specification changes without prior notification. Contact JLG Industries, Inc. for updated information.

SAFETY ALERT SYMBOLS AND SAFETY SIGNAL WORDS



This is the Safety Alert Symbol. It is used to alert you to the potential personal injury hazards. Obey all safety messages that follow this symbol to avoid possible injury or death.

⚠ DANGER

INDICATES AN IMMINENTLY HAZARDOUS SITUATION. IF NOT AVOIDED, WILL RESULT IN SERIOUS INJURY OR DEATH. THIS DECAL WILL HAVE A RED BACKGROUND.

⚠ WARNING

INDICATES A POTENTIALLY HAZARDOUS SITUATION. IF NOT AVOIDED, COULD RESULT IN SERIOUS INJURY OR DEATH. THIS DECAL WILL HAVE AN ORANGE BACKGROUND.

⚠ CAUTION

INDICATES A POTENTIALLY HAZARDOUS SITUATION. IF NOT AVOIDED, MAY RESULT IN MINOR OR MODERATE INJURY. IT MAY ALSO ALERT AGAINST UNSAFE PRACTICES. THIS DECAL WILL HAVE A YELLOW BACKGROUND.

NOTICE

INDICATES INFORMATION OR A COMPANY POLICY THAT RELATES DIRECTLY OR INDIRECTLY TO THE SAFETY OF PERSONNEL OR PROTECTION OF PROPERTY.

⚠ WARNING

THIS PRODUCT MUST COMPLY WITH ALL SAFETY RELATED BULLETINS. CONTACT JLG INDUSTRIES, INC. OR THE LOCAL AUTHORIZED JLG REPRESENTATIVE FOR INFORMATION REGARDING SAFETY-RELATED BULLETINS WHICH MAY HAVE BEEN ISSUED FOR THIS PRODUCT.

NOTICE

JLG INDUSTRIES, INC. SENDS SAFETY RELATED BULLETINS TO THE OWNER OF RECORD OF THIS MACHINE. CONTACT JLG INDUSTRIES, INC. TO ENSURE THAT THE CURRENT OWNER RECORDS ARE UPDATED AND ACCURATE.

NOTICE

JLG INDUSTRIES, INC. MUST BE NOTIFIED IMMEDIATELY IN ALL INSTANCES WHERE JLG PRODUCTS HAVE BEEN INVOLVED IN AN ACCIDENT INVOLVING BODILY INJURY OR DEATH OF PERSONNEL OR WHEN SUBSTANTIAL DAMAGE HAS OCCURRED TO PERSONAL PROPERTY OR THE JLG PRODUCT.

For:

- Accident Reporting
- Product Safety Publications
- Current Owner Updates
- Questions Regarding Product Safety
- Standards and Regulations Compliance Information
- Questions Regarding Special Product Applications
- Questions Regarding Product Modifications

Contact:

Product Safety and Reliability Department
JLG Industries, Inc.
13224 Fountainhead Plaza
Hagerstown, MD 21742
USA
or Your Local JLG Office
(See addresses on inside of manual cover)

In USA:

Toll Free: 877-JLG-SAFE (877-554-7233)

Outside USA:

Phone: +1-240-420-2661
Fax: 301-745-3713
E-mail: ProductSafety@JLG.com

REVISION LOG

Original Issue	- April 18, 2016
Manual revised	- June 08, 2016
Manual revised	- January 15, 2018
Manual revised	- November 12, 2019

SECTION - PARAGRAPH, SUBJECT	PAGE
SECTION - 1 - SAFETY PRECAUTIONS	
1.1 GENERAL	1-1
1.2 PRE-OPERATION	1-1
Operator Training and Knowledge	1-1
Workplace Inspection	1-2
Machine Inspection	1-3
1.3 OPERATION	1-3
General	1-3
Trip and Fall Hazards	1-5
Electrocution Hazards	1-6
Tipping Hazards	1-7
Crushing and Collision Hazards	1-10
1.4 TOWING, LIFTING, AND HAULING	1-11
1.5 MAINTENANCE	1-11
Maintenance Hazards	1-11
Battery Hazards	1-12
SECTION - 2 - USER RESPONSIBILITIES, MACHINE PREPARATION, AND INSPECTION	
2.1 PERSONNEL TRAINING	2-1
Operator Training	2-1
Training Supervision	2-2
Operator Responsibility	2-2

SECTION - PARAGRAPH, SUBJECT	PAGE
2.2 PREPARATION, INSPECTION, AND MAINTENANCE	2-2
2.3 PRE-START INSPECTION	2-4
2.4 DAILY WALK-AROUND INSPECTION	2-5
2.5 FUNCTION CHECK	2-8
Control Station	2-8
Tilt Sensor Check	2-9
Overload Sensor Check	2-10
Gate sensors check (8E XL basket only)	2-11
SECTION - 3 - MACHINE CONTROLS, INDICATORS AND OPERATION	
3.1 GENERAL	3-1
3.2 DESCRIPTION	3-1
3.3 OPERATING CHARACTERISTICS AND LIMITATIONS	3-2
General	3-2
Placards	3-2
Capacities	3-2
3.4 PLATFORM LOADING	3-2
Stability	3-3
3.5 MACHINE CONTROL LOCATIONS	3-5
3.6 CONTROLS AND INDICATORS	3-7
3.7 GROUND CONTROL STATION	3-7
Platform Manual Descent Valves - 8E	3-11
Mast Manual Descent Valve and Actuator - 8E	3-12

TABLE OF CONTENTS

SECTION - PARAGRAPH, SUBJECT	PAGE
Jib Manual Descent Valve - 8E	3-13
Manual Swinging Operating Devices - 8E.	3-14
Platform Manual Descent Valves - 10E.	3-16
Mast Manual Descent Valve and Actuator - 10E	3-17
Jib Manual Descent Valve - 10E	3-18
Manual Swinging Operating Devices - 10E.	3-19
3.8 PLATFORM CONTROL STATION	3-21
Grade and Side Slope.	3-25
3.9 OPERATION	3-27
3.10 STEERING AND TRAVELLING (DRIVING)	3-27
Steering	3-28
Travelling (driving)	3-28
Drive Orientation System (DOS)	3-29
3.11 RAISING AND LOWERING THE PLATFORM	3-30
Raising and lowering the mast	3-30
Raising and lowering the jib	3-30
3.12 SWINGING.	3-31
3.13 ALARMS	3-31
Overload Warning Light/Alarm	3-31
Tilt Warning Light/Alarm	3-31
Slack Chain Warning Light/Alarm	3-32
Gate Opening Warning Light (8E XL Basket Only)	3-33
3.14 MACHINE SAFETY SYSTEM OVERRIDE (MSSO) (IF EQUIPPED)	3-34

SECTION - PARAGRAPH, SUBJECT	PAGE
3.15 SHUT DOWN AND PARK	3-34
3.16 BATTERY CHARGING	3-35
Charger Interface	3-36
Troubleshooting	3-37
3.17 TIE-DOWN/LIFT LUGS.	3-41
Tie Down.	3-41
Lifting	3-43
3.18 TOWING.	3-44
Electric Brake Release	3-45

SECTION - 4 - EMERGENCY PROCEDURES

4.1 GENERAL INFORMATION	4-1
4.2 EMERGENCY OPERATION	4-1
Operator Unable to Control Machine.	4-1
Platform or Jib Caught Overhead	4-1
4.3 EMERGENCY CONTROL	4-1
4.4 PLATFORM MANUAL DESCENT.	4-3
4.5 INCIDENT NOTIFICATION	4-3
4.6 EMERGENCY TOWING	4-3
4.7 MACHINE SAFETY SYSTEM OVERRIDE (MSSO) (IF EQUIPPED).	4-4

SECTION - PARAGRAPH, SUBJECT	PAGE
SECTION - 5 - GENERAL SPECIFICATIONS AND MAINTENANCE	
5.1 INTRODUCTION	5-1
Other Publications Available Specific to this machine:	5-1
5.2 OPERATING SPECIFICATIONS	5-2
5.3 OPERATOR MAINTENANCE	5-11
5.4 CHASSIS HOOD REMOVAL	5-13
5.5 BATTERY MAINTENANCE	5-13
Battery Maintenance and Safety Practices	5-13
Battery Voltage	5-14
Use of a Battery in a Cold Environment	5-14
Battery Not Working Continuously or Inactive Battery	5-14
Battery Troubleshooting	5-15
5.6 OIL LEVEL/OIL FILTER - 8E	5-16
Hydraulic Oil Check	5-16
5.7 OIL LEVEL/OIL FILTER - 10E	5-17
Hydraulic Oil Check	5-17
5.8 HYDRAULIC FILTER REPLACEMENT	5-18
5.9 TIRES & WHEELS	5-19
Tire Wear and Damage	5-19
Wheel and Tire Replacement	5-19
Wheel Installation	5-19

SECTION - PARAGRAPH, SUBJECT	PAGE
5.10 DECAL INSTALLATION	5-21
5.11 LUBRICATION	5-28
Swing Bearing Race	5-29
Swing Bearing Teeth	5-30
Lifting Chains	5-31
5.12 OVERLOAD SYSTEM VERIFICATION	5-32
5.13 TILT SENSOR VERIFICATION	5-33
5.14 SLACK CHAIN SENSORS CHECK	5-34
5.15 SUPPLEMENTAL INFORMATION	5-35
5.16 DIAGNOSTIC TROUBLE CODES (DTC)	5-35
Introduction	5-35
5.17 DTC INDEX	5-35
5.18 DTC CHECK TABLES	5-36
0-0 Help Comments	5-36
2-1 Power-Up	5-37
2-2 Platform Controls	5-38
2-3 Ground Controls	5-40
2-5 Function Prevented	5-42
3-1 Line Contactor Open Circuit	5-44
3-2 Line Contactor Short Circuit	5-44
3-3 Ground Output Driver	5-45
4-2 Thermal Limit	5-48
4-4 Battery Supply	5-50
4-6 Transmission and Drive System	5-52

TABLE OF CONTENTS

SECTION - PARAGRAPH, SUBJECT

PAGE

6-6 Communication	5-53
6-7 Accessory	5-53
7-7 Electric Motor.	5-54
8-1 Tilt Sensor	5-55
8-2 Platform Load Sense	5-56
8-6 Steering/Axle	5-56
8-7 Safety System Override.	5-57
9-9 Hardware	5-58

SECTION - 6 - INSPECTION AND REPAIR LOG

SECTION - PARAGRAPH, SUBJECT

PAGE

SECTION - PARAGRAPH, SUBJECT PAGE

LIST OF TABLES

1-1 Minimum Approach Distance (M.A.D.) 1-6
1-2 Beaufort Scale (For Reference Only) 1-8
2-1 Inspection and Maintenance Table 2-3
5-1 Operating Specifications And Dimensions. 5-2
5-2 Dimensions 5-7
5-3 Tires Specifications. 5-7
5-4 Drive Motors - Hydraulic Power Unit 5-8
5-5 Battery Specifications 5-9
5-6 Lubrication Specifications 5-9
5-7 Hydraulic Oil Specifications - Standard 5-9
5-8 Hydraulic Oil Specifications - Optional. 5-10
5-9 Wheel Torque Chart 5-20
5-10 Machine Decal Installation Chart 5-27
5-11 Recommended Viscosity Grade. 5-31
6-1 Inspection and Repair Log 6-1

TABLE OF CONTENTS

SECTION - PARAGRAPH, SUBJECT	PAGE	SECTION - PARAGRAPH, SUBJECT	PAGE
LIST OF FIGURES			
2-1. Daily Walk-Around Inspection - 8E	2-6	3-20. Lifting the Machine	3-43
2-2. Daily Walk-Around Inspection - 10E	2-7	3-21. Lifting the Machine Using a Fork Truck	3-43
2-3. Tilt Sensor	2-9	3-22. Electric Brake Release	3-45
2-4. Overload Sensor	2-10	4-1. Emergency Controls	4-2
2-5. XL Basket	2-11	5-1. Range Diagram 8E & 8E-L	5-4
3-1. Position of Least BACKWARD stability	3-4	5-2. Range Diagram 8E XL	5-5
3-2. Position of Least FORWARD stability	3-4	5-3. Range Diagram 10E & 10E-L	5-6
3-3. Basic Nomenclature - Machine Control Locations - 8E	3-5	5-4. Operator Maintenance & Lubrication Diagram - 8E	5-11
3-4. Basic Nomenclature - Machine Control Locations - 10E	3-6	5-5. Operator Maintenance & Lubrication Diagram - 10E	5-12
3-5. Ground Control Station	3-8	5-6. Chassis Hood Removal	5-13
3-6. Mast Manual Descent Valve - 8E	3-12	5-7. Hydraulic Oil Check - 8E	5-16
3-7. Jib Manual Descent Valve - 8E	3-13	5-8. Hydraulic Oil Check - 10E	5-17
3-8. Rotary Valve - 8E	3-14	5-9. Hydraulic Filter Replacement	5-18
3-9. Solid Hand Wheel - 8E	3-14	5-10. Decal Installation - 8E Sheet 1	5-21
3-10. Mast Manual Descent Valve - 10E	3-17	5-11. Decal Installation - 8E Sheet 2	5-22
3-11. Jib Manual Descent Valve - 10E	3-18	5-12. Decal Installation - 8E Sheet 3	5-23
3-12. Manual Swinging Operating Devices - 10E	3-19	5-13. Decal Installation - 10E Sheet 1	5-24
3-13. Platform Control Station	3-21	5-14. Decal Installation - 10E Sheet 2	5-25
3-14. Platform Control Indicator Panel	3-22	5-15. Decal Installation - 10E Sheet 3	5-26
3-15. Grade and Side Slope	3-26	5-16. Swing Bearing Race Lubrication	5-29
3-16. Steer/Drive Controls	3-28	5-17. Swing Bearing Teeth Lubrication	5-30
3-17. Drive Orientation System (DOS)	3-29	5-18. Overload System Verification	5-32
3-18. Machine Tie-Down - 8E	3-41	5-19. Jacking Points	5-33
3-19. Machine Tie-Down - 10E	3-42	5-20. Slack/Broken Chain Sensors	5-34

SECTION 1. SAFETY PRECAUTIONS

1.1 GENERAL

This section outlines the necessary precautions for proper and safe machine operation and maintenance. In order to promote proper machine usage, it is mandatory that a daily routine is established based on the content of this manual. A maintenance program, using the information provided in this manual and the Service and Maintenance Manual, must also be established by a qualified person and must be followed to ensure that the machine is safe to operate.

The owner/user/operator/lessor/lessee of the machine must not accept operating responsibility until this manual has been read, training is accomplished, and operation of the machine has been completed under the supervision of an experienced and qualified operator.

These sections contain the responsibilities of the owner, user, operator, lessor, and lessee concerning safety, training, inspections, maintenance, application, and operation. If there are any questions with regard to safety, training, inspection, maintenance, application, and operation, please contact JLG Industries, Inc. (“JLG”).

⚠ WARNING

FAILURE TO COMPLY WITH THE SAFETY PRECAUTIONS LISTED IN THIS MANUAL COULD RESULT IN MACHINE DAMAGE, PROPERTY DAMAGE, PERSONAL INJURY OR DEATH.

1.2 PRE-OPERATION

Operator Training and Knowledge

- The Operation and Safety Manual must be read and understood in its entirety before operating the machine. For clarification, questions, or additional information regarding any portions of this manual, contact JLG Industries, Inc.

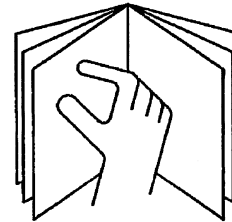

SECTION 1 – SAFETY PRECAUTIONS

- An operator must not accept operating responsibilities until adequate training has been given by competent and authorized persons.
- Allow only those authorized and qualified personnel to operate the machine who have demonstrated that they understand the safe and proper operation and maintenance of the unit.
- Read, understand, and obey all DANGERS, WARNINGS, CAUTIONS, and operating instructions on the machine and in this manual.
- Ensure that the machine is to be used in a manner which is within the scope of its intended application as determined by JLG.
- All operating personnel must be familiar with the emergency controls and emergency operation of the machine as specified in this manual.
- Read, understand, and obey all applicable employer, local, and governmental regulations as they pertain to your utilization and application of the machine.

Workplace Inspection

- Precautions to avoid all hazards in the work area must be taken by the user before and during operation of the machine.
- Do not operate or raise the platform from a position on trucks, trailers, railway cars, floating vessels, scaffolds or other equipment unless the application is approved in writing by JLG.
- Before operation, check work area for overhead hazards such as electric lines, bridge cranes, and other potential overhead obstructions.
- Check floor surfaces for holes, bumps, drop-offs, obstructions, debris, concealed holes, and other potential hazards.
- Check the work area for hazardous locations. Do not operate the machine in hazardous environments unless approved for that purpose by JLG.
- Be sure that the ground conditions are able to support the maximum load shown on the decals located on the machine.
- This machine can be operated in nominal ambient temperatures of -20° C to 40° C (0° F to 104° F). Consult JLG to optimize operation outside of this temperature range.
- This machine must be used in a sufficient ambient light.

Machine Inspection

- Do not operate this machine until the inspections and functional checks have been performed as specified in Section 2 of this manual.
- Do not operate this machine until it has been serviced and maintained according to the maintenance and inspection requirements as specified in the machine's Service and Maintenance Manual.
- Ensure all safety devices are operating properly. Modification of these devices is a safety violation.

WARNING

MODIFICATION OR ALTERATION OF AN AERIAL WORK PLATFORM SHALL BE MADE ONLY WITH PRIOR WRITTEN PERMISSION FROM THE MANUFACTURER.

- Do not operate any machine on which the safety or instruction placards or decals are missing or illegible.
- Check the machine for modifications to original components. Ensure that any modifications have been approved by JLG.
- Avoid accumulation of debris on platform deck. Keep mud, oil, grease, and other slippery substances from footwear and platform deck.

1.3 OPERATION

General

- Machine operation requires your full attention. Bring the machine to a full stop before using any device, i.e. cell phones, two-way radios, etc. that will distract your attention from safely operating the machine.
- Do not use the machine for any purpose other than positioning personnel, their tools, and equipment.
- Before operation, the user must be familiar with the machine capabilities and operating characteristics of all functions.
- Never operate a malfunctioning machine. If a malfunction occurs, shut down the machine. Remove the unit from service and notify the proper authorities.
- Do not remove, modify, or disable any safety devices.
- Never slam a control switch or lever through neutral to an opposite direction. Always return switch to neutral and stop before moving the switch to the next function. Operate controls with slow and even pressure.
- Do not allow personnel to tamper with or operate the machine from the ground with personnel in the platform, except in an emergency.

SECTION 1 – SAFETY PRECAUTIONS

- Do not carry materials directly on platform railing unless approved by JLG.
- When two or more persons are in the platform, the operator shall be responsible for all machine operations.
- Always ensure that power tools are properly stowed and never left hanging by their cord from the platform work area.
- Do not assist a stuck or disabled machine by pushing or pulling except by pulling at the chassis tie-down lugs.
- Fully lower platform and shut off all power before leaving machine.
- Remove all rings, watches, and jewelry when operating machine. Do not wear loose fitting clothing or long hair unrestrained which may become caught or entangled in equipment.
- Persons under the influence of drugs or alcohol or who are subject to seizures, dizziness or loss of physical control must not operate this machine.

Trip and Fall Hazards

- Prior to operation, ensure all gates are fastened and secured in their proper position.

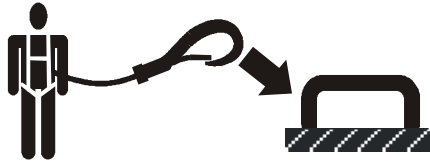

- During operation, occupants in the platform must wear a full body harness with a lanyard attached to an authorized lanyard anchorage point. Attach only one (1) lanyard per lanyard anchorage point.
- Identify the designated lanyard anchorage point(s) at the platform and securely attach the lanyard. Attach only one (1) lanyard per lanyard anchorage point.
- Enter and exit only through gate area. Use extreme caution when entering or leaving platform. Ensure that the platform assembly is fully lowered. Face the machine when entering or leaving the platform. Always maintain “three point contact” with the machine, using two hands

and one foot or two feet and one hand at all times during entry and exit.

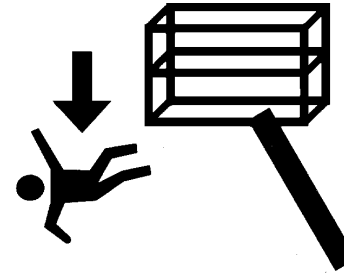

- Keep both feet firmly positioned on the platform floor at all times. Never position ladders, boxes, steps, planks, or similar items on unit to provide additional reach for any purpose.
- Never use extending structure to gain access to or leave the platform.
- Keep oil, mud, and slippery substances cleaned from footwear and the platform floor.

Electrocution Hazards

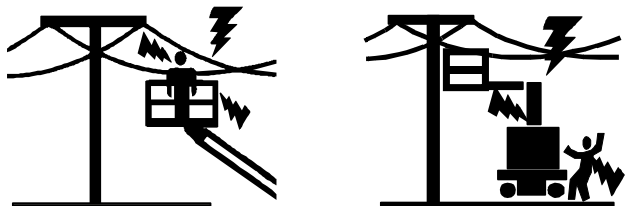

- This machine is not insulated and does not provide protection from contact or proximity to electrical current.
- Maintain distance from electrical lines, apparatus, or any energized (exposed or insulated) parts according to the Minimum Approach Distance (MAD) as shown in Table 1-1.
- Allow for machine movement and electrical line swaying.
- Maintain a clearance of at least 3 m (10 ft.) between any part of the machine and its occupants, their tools and their equipment from any electrical line or apparatus carrying up to 50 000 volts. A 0,3 m (1 ft.) additional clearance is required for every additional 30 000 volts or less.
- The minimum approach distance may be reduced if insulating barriers are installed to prevent contact and the barriers are rated for the voltage of the line being guarded. These barriers shall not be part of (or attached to) the

machine. The minimum approach distance shall be reduced to a distance within the designed working dimensions of the insulating barrier. This determination shall be made by a qualified person in accordance with the employer, local or governmental requirements for work practices near energized equipment.

Table 1-1. Minimum Approach Distance (M.A.D.)

Voltage Range (Phase to Phase)	MINIMUM APPROACH DISTANCE in Meters (Feet)
0 to 50 kV	3 (10)
Over 50 kV to 200 kV	5 (15)
Over 200kV to 350 kV	6 (20)
Over 350 kV to 500 kV	8 (25)
Over 500 kV to 750 kV	11 (35)
Over 750 kV to 1000 kV	14 (45)

NOTE: *This requirement shall apply except where employer, local or governmental regulations are more stringent.*

⚠ DANGER

DO NOT MANEUVER MACHINE OR PERSONNEL INSIDE PROHIBITED ZONE (MAD). ASSUME ALL ELECTRICAL PARTS AND WIRING ARE ENERGIZED UNLESS KNOWN OTHERWISE.

Tipping Hazards

- Ensure that the ground conditions are adequate to support the maximum tire load indicated on the tire load decal located on the chassis. Do not travel on unsupported surfaces.
- The user must be familiar with the driving surface before driving. Do not exceed the allowable sideslope and grade while driving.
- Do not elevate platform or drive with platform elevated while on or near a sloping, uneven, or soft surface. Ensure machine is positioned on a firm, level and smooth surface before elevating platform or driving with the platform in the elevated position.
- Never exceed the maximum work load as specified on the platform. Keep all loads within the confines of the platform, unless authorized by JLG.
- Keep the chassis of the machine a minimum of 0.6 m (2 ft.) from holes, bumps, drop-offs, obstructions, debris, concealed holes, and other potential hazards at the ground level.
- Do not operate the machine when wind conditions exceed the maximum operating wind speed as specified on the platform.

SECTION 1 – SAFETY PRECAUTIONS

NOTICE

IF THE MACHINE IS USABLE WITH WIND (DEPENDING ON MODEL), DO NOT OPERATE THE MACHINE WHEN WIND CONDITIONS EXCEED 28 MPH (12,5 M/S OR 45 KM/H).

Table 1-2. Beaufort Scale (For Reference Only)

Beaufort Number	Wind Speed		Description	Land Conditions
	mph	m/s		
0	0	0-0.2	Calm	Calm. Smoke rises vertically.
1	1-3	0.3-1.5	Light air	Wind motion visible in smoke.
2	4-7	1.6-3.3	Light breeze	Wind felt on exposed skin. Leaves rustle.
3	8-12	3.4-5.4	Gentle breeze	Leaves and smaller twigs in constant motion.
4	13-18	5.5-7.9	Moderate breeze	Dust and loose paper raised. Small branches begin to move.
5	19-24	8.0-10.7	Fresh breeze	Smaller trees sway.
6	25-31	10.8-13.8	Strong breeze	Large branches in motion. Flags waving near horizontal. Umbrella use becomes difficult.
7	32-38	13.9-17.1	Near Gale/Moderate Gale	Whole trees in motion. Effort needed to walk against the wind.
8	39-46	17.2-20.7	Fresh Gale	Twigs broken from trees. Cars veer on road.
9	47-54	20.8-24.4	Strong gale	Light structure damage.

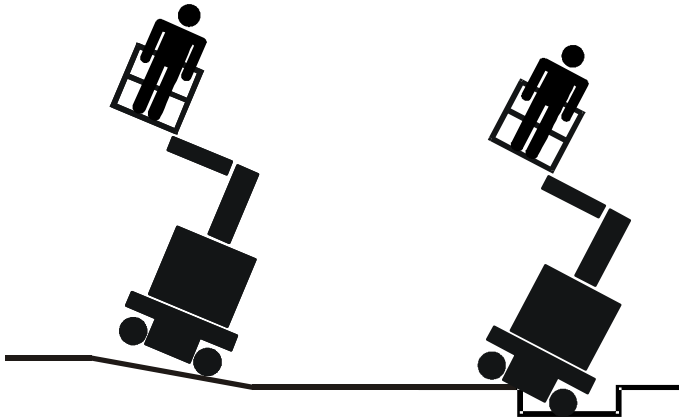

- If the extending structure assembly or platform is caught so that one or more wheels are off the ground, all persons must be removed before attempting to free the machine. Use cranes, forklift trucks, or other appropriate equipment to stabilize machine and remove personnel.

- Never attempt to use the machine as a crane. Do not tie-off machine to any adjacent structure. Never attach wire, cable, or any similar items to platform.
- Do not cover the platform sides or carry large surface-area items in the platform when operating outdoors. The addition of such items increases the exposed wind area of the machine.
- Do not increase the platform size with unauthorized deck extensions or attachments.

SECTION 1 – SAFETY PRECAUTIONS

Crushing and Collision Hazards

- Approved head gear must be worn by all operating and ground personnel.
- Check work area for clearances overhead, on sides, and bottom of platform when lifting, swinging or lowering platform, and driving.
- During operation, keep all body parts inside platform railing.

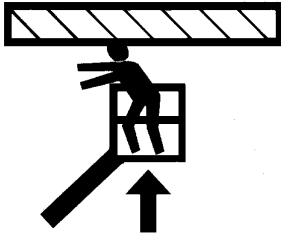

- Always post a lookout when driving in areas where vision is obstructed.
- Keep non-operating personnel at least 2m (6 ft.) away from machine during all operations.
- Limit travel speed according to conditions of ground surface, congestion, visibility, slope, location of personnel,

and other factors which may cause hazard of collision or injury to personnel.

- Be aware of stopping distances in all drive speeds. When driving in high speed, slow down the machine using the controller before stopping.
- Do not use high speed drive in restricted or close quarters or when driving in reverse.
- Exercise extreme caution at all times to prevent obstacles from striking or interfering with operating controls and persons in the platform.
- Ensure that operators of other overhead and floor level machines are aware of the aerial work platform's presence. Disconnect power to overhead cranes. Barricade floor area if necessary.
- Do not operate over ground personnel. Warn personnel not to work, stand, or walk under a raised platform. Position barricades on floor as necessary.

1.4 TOWING, LIFTING, AND HAULING

- Never allow personnel in platform while towing, lifting, or hauling.
- This machine should not be towed, except in the event of emergency, malfunction, power failure, or loading/unloading. Refer to Emergency Towing Procedures.
- Ensure extending structure is fully retracted and that the platform and the tool tray are completely empty of tools prior to towing, lifting or hauling.
- Refer to Section 3 for lifting information.

1.5 MAINTENANCE

This sub-section contains general safety precautions which must be observed during maintenance of this machine. Additional precautions to be observed during machine maintenance are inserted at the appropriate points in this manual and in the Service and Maintenance Manual. It is of utmost importance that maintenance personnel pay strict attention to these precautions to avoid possible injury to personnel or damage to the machine or property. A maintenance program must be established by a qualified person and must be followed to ensure that the machine is safe.

Maintenance Hazards

- Shut off power to all controls and ensure that all moving parts are secured from inadvertent motion prior to performing any adjustments or repairs.
- Never work under an elevated platform until it has been fully lowered to the full down position, if possible, or otherwise supported and restrained from movement with appropriate safety props, blocking, or overhead supports.
- DO NOT attempt to repair or tighten any hydraulic hoses or fittings while the machine is powered on or when the hydraulic system is under pressure.
- Always relieve hydraulic pressure from all hydraulic circuits before loosening or removing hydraulic components.
- DO NOT use your hand to check for leaks. Use a piece of cardboard or paper to search for leaks. Wear gloves to help protect hands from spraying fluid.

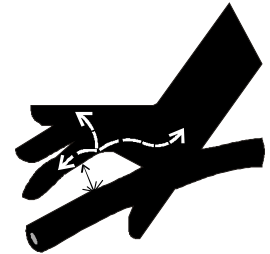

SECTION 1 – SAFETY PRECAUTIONS

- Ensure replacement parts or components are identical or equivalent to original parts or components.
- Never attempt to move heavy parts without the aid of a mechanical device. Do not allow heavy objects to rest in an unstable position. Ensure adequate support is provided when raising components of the machine.
- Use only approved non-flammable cleaning solvents.
- Do not replace items critical to stability, such as batteries or solid tires, with items of different weight or specification. Do not modify unit in any way to affect stability.
- Reference the Service and Maintenance Manual for the weights of critical stability items.

⚠ WARNING

MODIFICATION OR ALTERATION OF AN AERIAL WORK PLATFORM SHALL BE MADE ONLY WITH PRIOR WRITTEN PERMISSION FROM THE MANUFACTURER.

Battery Hazards

- Always disconnect batteries when servicing electrical components or when performing welding on the machine.
- Do not allow smoking, open flame, or sparks near battery during charging or servicing.

- Do not contact tools or other metal objects across the battery terminals.

⚠ CAUTION

BATTERY FLUID IS HIGHLY CORROSIVE. AVOID CONTACT WITH SKIN AND CLOTHING AT ALL TIMES. IMMEDIATELY RINSE ANY CONTACTED AREA WITH CLEAN WATER AND SEEK MEDICAL ATTENTION.

- Charge batteries only in a well ventilated area.

SECTION 2. USER RESPONSIBILITIES, MACHINE PREPARATION, AND INSPECTION

2.1 PERSONNEL TRAINING

The aerial platform is a personnel handling device; so it is necessary that it be operated and maintained only by trained personnel.

Operator Training

Operator training must cover:

- Use and limitations of the controls in the platform and at the ground, emergency controls and safety systems.
- Control labels, instructions, and warnings on the machine.
- Rules of the employer and government regulations.
- Use of approved fall protection device.
- Enough knowledge of the mechanical operation of the machine to recognize a malfunction or potential malfunction.
- The safest means to operate the machine where overhead obstructions, other moving equipment, and obstacles, depressions, holes or drop-offs exist.
- Means to avoid the hazards of unprotected electrical conductors.
- Specific job requirements or machine application.
- Reading and understanding the Operation and Safety manual.

Training Supervision

Training must be done under the supervision of a qualified person in an open area free of obstructions until the trainee has developed the ability to safely control and operate the machine.

Operator Responsibility

The operator must be instructed that he/she has the responsibility and authority to shut down the machine in case of a malfunction or other unsafe condition of either the machine or the job site.

NOTE: *The Manufacturer or Distributor will provide qualified people for training assistance with the first unit(s) delivered and from that time forward as requested by the user or his/her personnel.*

2.2 PREPARATION, INSPECTION, AND MAINTENANCE

Table 2-1 explains the periodic machine inspections and maintenance required by JLG Industries, Inc. Consult local regulations for further requirements for aerial work platforms. The frequency of inspections and maintenance must be increased as necessary when the machine is used in a harsh or hostile environment, if the machine is used with increased frequency, or if the machine is used in a severe manner.

SECTION 2 – USER RESPONSIBILITIES, MACHINE PREPARATION, AND INSPECTION

Table 2-1. Inspection and Maintenance Table

Type	Frequency	Primary Responsibility	Service Qualification	Reference
Pre-Start Inspection	Before using each day; or whenever there's an Operator change.	User or Operator	User or Operator	Operation and Safety Manual
Pre-Delivery Inspection (See Note)	Before each sale, lease, or rental delivery.	Owner, Dealer or User	Qualified JLG Mechanic	Service and Maintenance Manual and applicable JLG inspection form
Frequent Inspection (See Note)	In service for 3 months or 150 hours, whichever comes first; or Out of service for a period of more than 3 months; or Purchased used.	Owner, Dealer or User	Qualified JLG Mechanic	Service and Maintenance Manual and applicable JLG inspection form
Annual Machine Inspection (See Note)	Annually, no later than 13 months from the date of prior inspection.	Owner, Dealer or User	Factory-Trained Service Technician (Recommended)	Service and Maintenance Manual and applicable JLG inspection form
Preventative Maintenance	At intervals as specified in the Service and Maintenance Manual.	Owner, Dealer or User	Qualified JLG Mechanic	Service and Maintenance Manual

NOTE: *Inspection forms are available from JLG. Use the Service and Maintenance Manual to perform inspections.*

NOTICE

JLG INDUSTRIES, INC. RECOGNIZES A FACTORY-TRAINED SERVICE TECHNICIAN AS A PERSON WHO HAS SUCCESSFULLY COMPLETED THE JLG SERVICE TRAINING SCHOOL FOR THE SPECIFIC JLG PRODUCT MODEL.

2.3 PRE-START INSPECTION

The Pre-Start Inspection should include each of the following:

1. **Cleanliness** – Check all surfaces for leakage (oil or battery fluid) or foreign objects. Report this to the proper maintenance personnel.
2. **Structure** – Inspect the machine structure for dents, damage, weld or parent metal cracks or other discrepancies. Report this to the proper maintenance personnel.

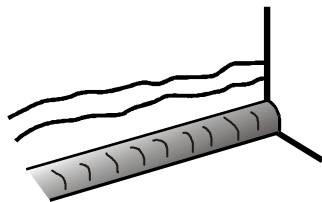

Parent Metal Crack

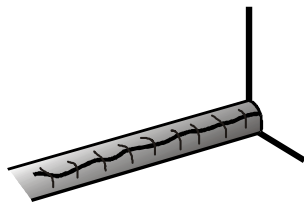

Weld Crack

3. **Decals and Placards** – Check all for cleanliness and legibility. Ensure none of the decals and placards are missing. Ensure all illegible decals and placards are cleaned or replaced. (See Section 5-10 - DECAL INSTALLATION)

4. **Operation and Safety Manuals** – Ensure that a copy of the Operation and Safety manual, AEM Safety Manual (ANSI markets only), and ANSI Manual of Responsibility (ANSI markets only) is enclosed in the weather resistant storage container.
5. **“Walk-Around” Inspection** – Refer to Figure 2-1. or Figure 2-2. depending on model.
6. **Battery** – Charge as required.
7. **Hydraulic Oil** – Check the hydraulic oil level in the reservoir, add as required.
8. **Accessories/Attachments** - Reference the Operation and Safety Manual of each attachment or accessory installed upon the machine for specific inspection, operation, and maintenance instructions.
9. **Function Check** – Once the “Walk-Around” Inspection is complete, perform a functional check of all systems in an area free of overhead and ground level obstructions. Refer to Section 3 for more specific instructions on the operation of each function.

2.4 DAILY WALK-AROUND INSPECTION

Begin the “Walk-Around Inspection” at Item 1, see Figure 2-1. or Figure 2-2. depending on model. Continue checking each item in sequence for the conditions listed in the following checklist.

WARNING

TO AVOID POSSIBLE INJURY, BE SURE MACHINE POWER IS OFF. DO NOT OPERATE MACHINE UNTIL ALL MALFUNCTIONS HAVE BEEN CORRECTED.

INSPECTION NOTE: *On all components, make sure there are no loose or missing parts, that they are securely fastened, and no visible damage, leaks or excessive wear exists in addition to any other criteria mentioned.*

- 1. Platform Assembly and Gate** - Gate opens and closes properly, manual in storage container. See inspection note.
- 2. Ground Control Console** - Placards secure and legible, control switches return to neutral position and emergency stop switches function properly. Control markings legible.
- 3. Platform Control Console** - Ensure that the control console is firmly secured in the proper location. Placards secure and legible, control lever and switches return to neutral position and emergency stop switch functions properly.
- 4. Steering Assembly** - See inspection note.
- 5. Wheel/Tire Assemblies** - Properly secured, no missing lug nuts. Inspect for worn tread, cuts, tears or other discrepancies. Inspect wheels for damage and corrosion. See inspection note.
- 6. Hood Assemblies** - See Inspection Note.
- 7. Hydraulic Cylinders**- No visible damage, pivot pins and hydraulic hoses undamaged, no leakage (hose connections - valve block).
- 8. Manual Descent Control** - See Inspection Note.
- 9. Lifting Chains, Chain Yokes and Clevis Pins** - Must be installed and in good condition. Chains must be correctly tensioned and lubricated.
- 10. Hydraulic Pump/Motor, Control Valves Installation/ Oil Level in Reservoir** - Swing needle valve fully closed. No unsupported wires or hoses; no damaged or broken wires. See Inspection Note.
- 11. Limit Switches** - Mast limit switch(es), chain slack limit switches and overload sensor are properly installed and fastened. See inspection note.

SECTION 2 – USER RESPONSIBILITIES, MACHINE PREPARATION, AND INSPECTION

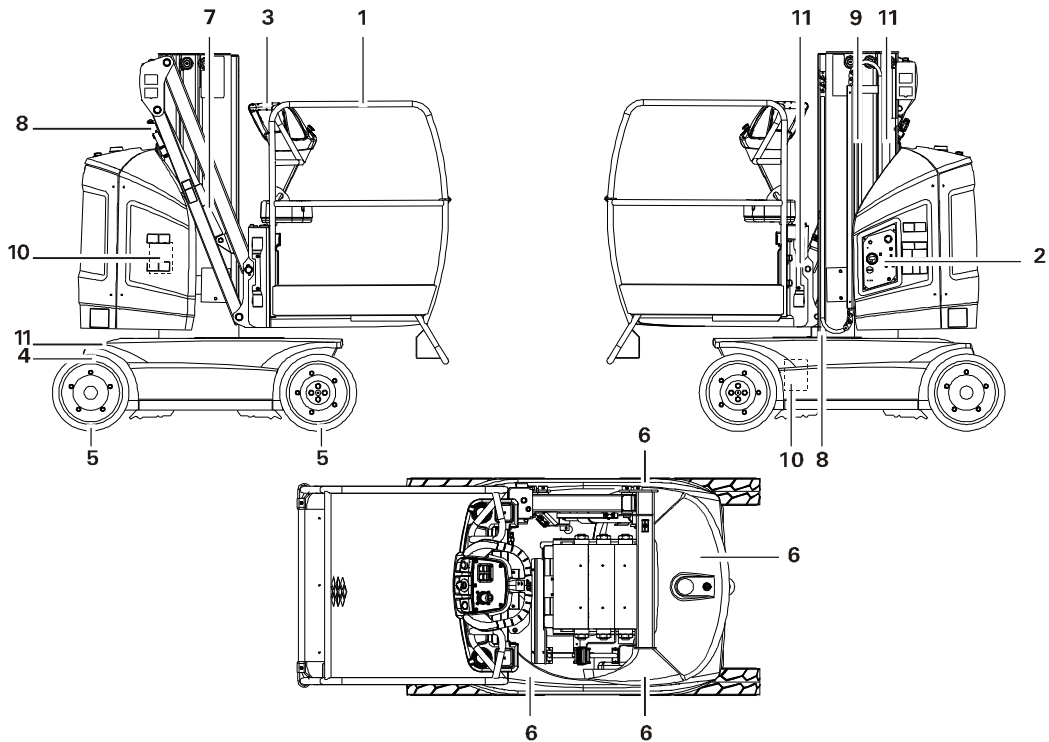

Figure 2-1. Daily Walk-Around Inspection - 8E

SECTION 2 – USER RESPONSIBILITIES, MACHINE PREPARATION, AND INSPECTION

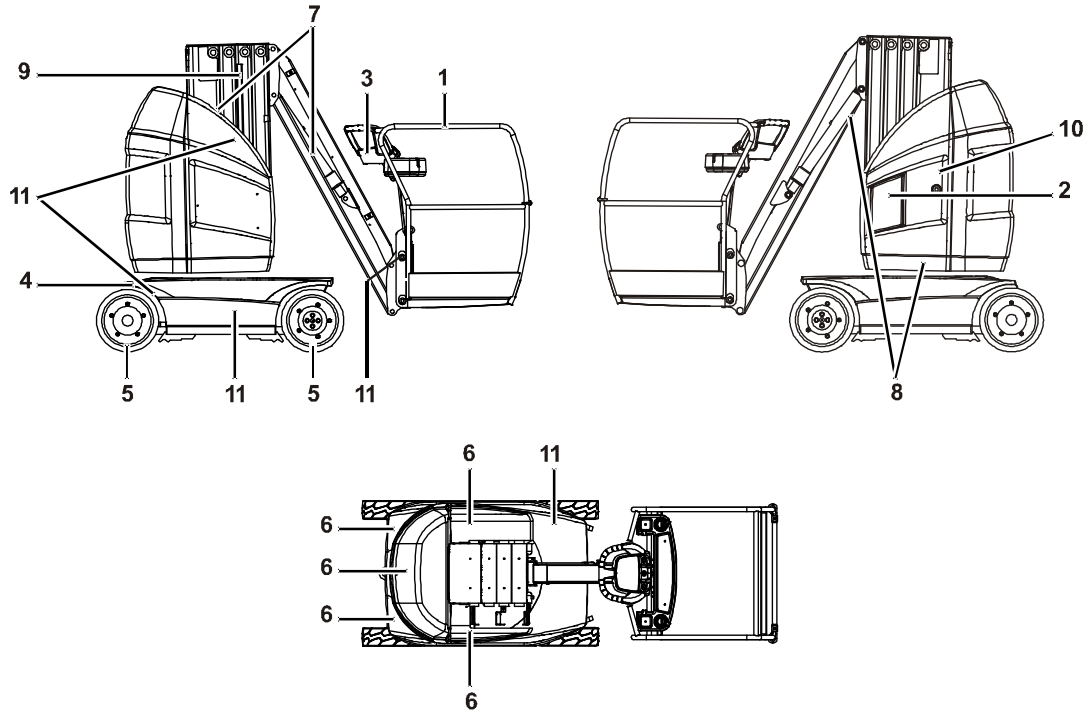

Figure 2-2. Daily Walk-Around Inspection - 10E

2.5 FUNCTION CHECK

Refer to Section 3 for description and operation of machine functions.

Control Station

1. From the **Ground Control Panel** with no load in the platform:
 - a. Operate all functions to ensure proper operation.
 - b. While operating a mast lift-up movement, push in all other function buttons. Mast lift-up movement should continue and no other movement should occur.
 - c. Ensure that all machine functions are disabled when the emergency stop button is depressed.
 - d. Ensure all mast and jib functions stop when the function enable button is released.
 - e. Raise the mast about one meter (3 ft.), check if the manual descent valve lowers the mast properly.
 - f. Raise the jib about half a meter (2 ft.), check if the manual descent valve lowers the jib properly.
2. From the **Platform Control Console**:
 - a. Operate all functions including horn button to ensure proper operation.
 - b. Ensure that all machine functions are disabled when the emergency stop button is depressed.
 - c. Ensure all mast and jib functions stop when the function enable button is released.
 - d. Ensure all drive functions stop when joystick trigger is released.
 - e. With the mast elevated half a meter (2 ft.), on a smooth, firm and level surface, drive the machine to check if the high drive cutout speed-limit is engaged. Drive speed will be reduced from a top speed of 5.5 km/h to 0.75 km/h (3.40 mph to 0.45 mph) (Approx.).
 - f. Toucan 10E only: With the mast elevated 4.50 m (14.8 ft.), on a smooth, firm and level surface, drive the machine to check if the extra drive cutout speed-limit is engaged. Drive speed will be reduced to 0.40 km/h (0.25 mph) (Approx.).

3. With the platform in the transport (stowed) position:
 - a. Swing the boom over either of the rear tires and ensure that the Drive Orientation indicator illuminates and that the Drive Orientation Override switch must be used for the drive function to operate. Reposition the platform in line with the chassis.
 - b. Drive the machine on a grade, not to exceed the rated gradeability, and stop to ensure the brakes hold;
 - c. Check that the tilt indicator is illuminated to ensure proper operation.

Tilt Sensor Check

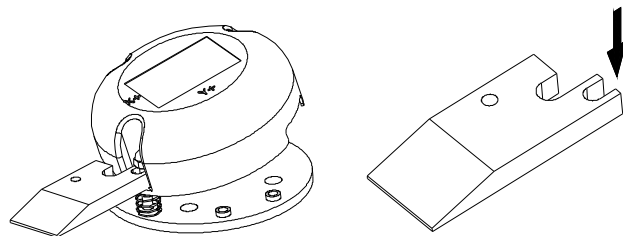

Figure 2-3. Tilt Sensor

Check the tilt indicator light/alarm to ensure proper operation. Wedge a block (P/N: ST2741 - located in the manual storage container) to activate the tilt sensor and keep it tilted. The tilt sensor is located on the chassis behind the right rear wheel. Refer to Figure 2-3.

1. From the platform console:
 - Raise the mast by approximately 1 m (3 ft.).
 - a. Confirm an audible alarm sounds.
 - b. Verify the tilt indicator (red) blinks.
 - c. Check that the following functions are affected :
 - Drive function disabled.
 - Mast/Jib lift-up and swinging movements can be performed only in creep mode.

Overload Sensor Check

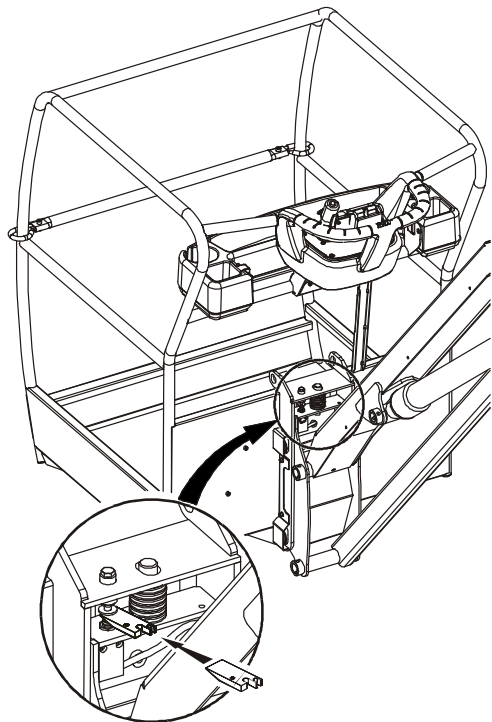

Figure 2-4. Overload Sensor

Check the overload indicator light/alarm to ensure proper operation. Wedge a block (P/N: ST2741 - located in the manual storage container) to activate the overload sensor and keep it activated. Refer to Figure 2-4.

- 1.** From the Platform Control Console:
 - a.** Confirm an audible alarm sounds.
 - b.** Verify the overload indicator (Red) blinks.
 - c.** Check that all functions are disabled.
- 2.** From the Ground Control Panel:
 - a.** Confirm an audible alarm sounds.
 - b.** Verify the overload indicator (Red) blinks.

Gate sensors check (8E XL basket only)

Check proper operation of the gate opening warning light and interlock. Open each gate in turn.

- 1.** From the Platform Control Console:
 - a.** Ensure the gate open warning light is illuminated.
 - b.** Check that all functions are disabled.
- 2.** From the Ground Control Console:
 - a.** Check that all functions are disabled.

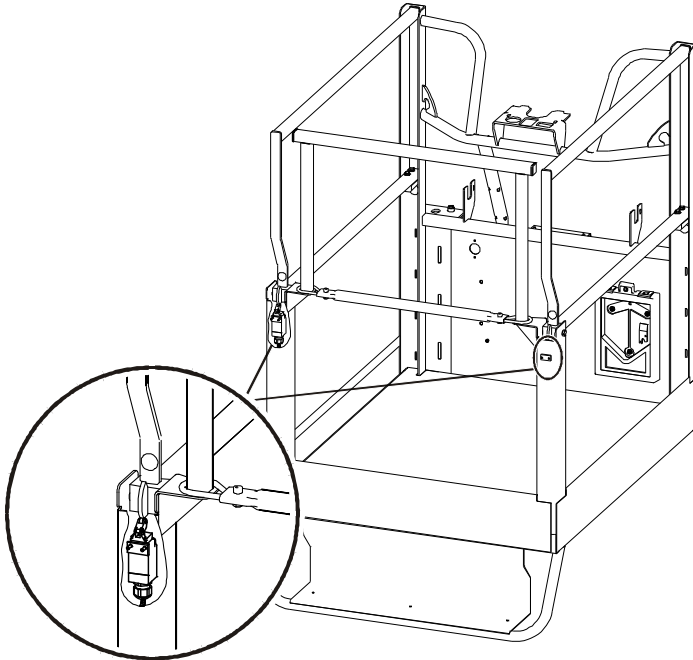

Figure 2-5. XL Basket

SECTION 3. MACHINE CONTROLS, INDICATORS AND OPERATION

3.1 GENERAL

NOTICE

THE MANUFACTURER HAS NO DIRECT CONTROL OVER MACHINE APPLICATION AND OPERATION, THE USER AND OPERATOR ARE RESPONSIBLE FOR CONFORMING WITH GOOD SAFETY PRACTICES.

This section provides the necessary information needed to understand controls and their functions.

⚠ WARNING

DO NOT RAISE PLATFORM EXCEPT ON A SMOOTH, FIRM AND LEVEL SURFACE FREE OF OBSTRUCTIONS AND HOLES.

TO AVOID SERIOUS INJURY, DO NOT OPERATE MACHINE IF ANY CONTROL LEVERS OR TOGGLE SWITCHES CONTROLLING PLATFORM MOVEMENT DO NOT RETURN TO THE OFF OR NEUTRAL POSITION WHEN RELEASED.

IF THE PLATFORM DOES NOT STOP WHEN A CONTROL SWITCH OR LEVER IS RELEASED, USE THE EMERGENCY STOP SWITCH TO STOP THE MACHINE.

3.2 DESCRIPTION

This machine is a self-propelled hydraulic lift equipped with a work platform on the end of an elevating and rotating mast.

The primary operator control station is in the platform and shall only be accessed with the extending structure fully stowed. From this control station, the operator can drive and steer the machine in both forward and reverse directions. The operator can raise or lower the mast and the jib, or swing the mast to the left or right. Standard mast swing is 172.5 degrees left and right of the stowed position. The machine has a Ground Control Station which will override the Platform Control Station. Ground Controls operate mast, jib and swing and are to be used in an emergency to lower the platform to the ground should the operator in the platform be unable to do so. The Ground Control is also to be used in Pre-Start Inspection.

3.3 OPERATING CHARACTERISTICS AND LIMITATIONS

General

A thorough knowledge of the operating characteristics and limitations of the machine is always the first requirement for any user, regardless of user's experience with similar types of equipment.

Placards

Important points to remember during operation are provided at the control stations by DANGER, WARNING, CAUTION, NOTICE, and INSTRUCTION placards. This information is placed at various locations for the express purpose of alerting personnel of potential hazards constituted by the operating characteristics and limitations of the machine. See foreword for definitions of placard safety signal words.

Capacities

The mast and the jib can be raised above horizontal with or without any load in the platform if:

1. Machine is positioned on a smooth, firm and level surface.
2. Load is within manufacturer's rated design capacity.
3. All machine systems are functioning properly.
4. Machine is as originally equipped from JLG.

3.4 PLATFORM LOADING

The platform maximum rated load capacity is shown on a placard located on the platform billboard and ground control station and is based upon the machine positioned on a smooth, firm, and level surface. Refer to Section 5 for the maximum platform capacity.

The platform is entered through an entry gate at the rear of the platform. Keep entry gate closed during machine operation.

Stability

Machine stability is based on two (2) conditions which are called FORWARD and BACKWARD stability. The machine's position of least FORWARD stability is shown in Figure 3-2. and its position of least BACKWARD stability is shown in Figure 3-1.

WARNING

TO AVOID FORWARD OR BACKWARD TIPPING, DO NOT OVERLOAD MACHINE OR OPERATE THE MACHINE ON AN OUT-OF-LEVEL SURFACE

SECTION 3 – MACHINE CONTROLS, INDICATORS AND OPERATION

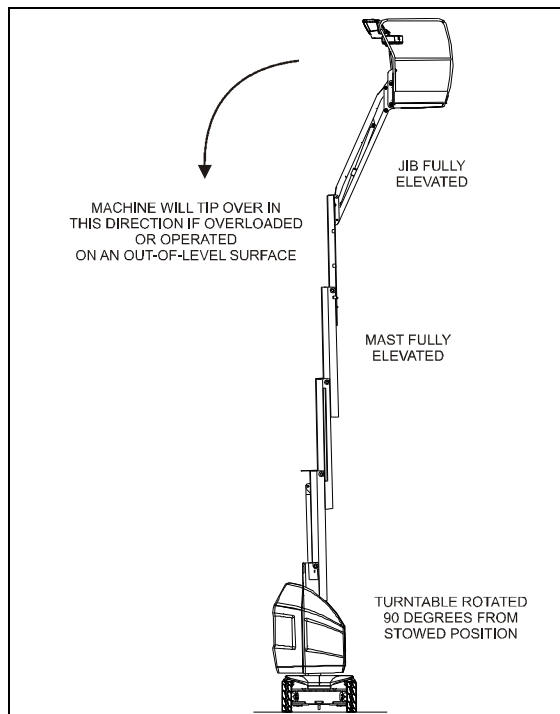

Figure 3-1. Position of Least BACKWARD stability

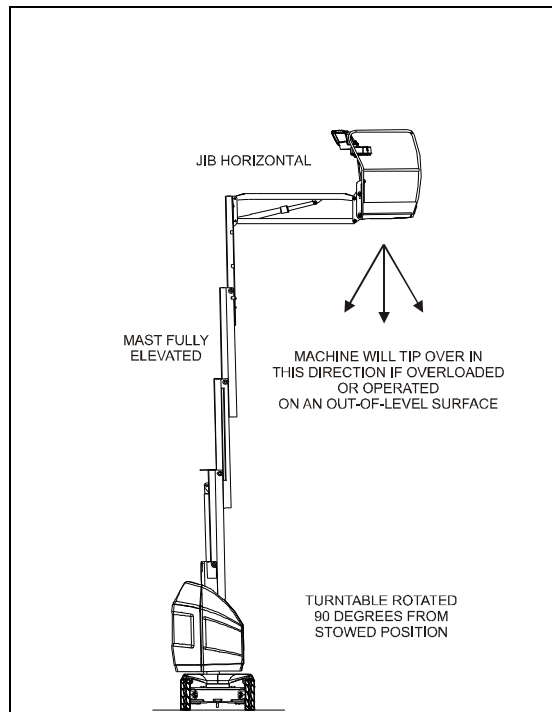
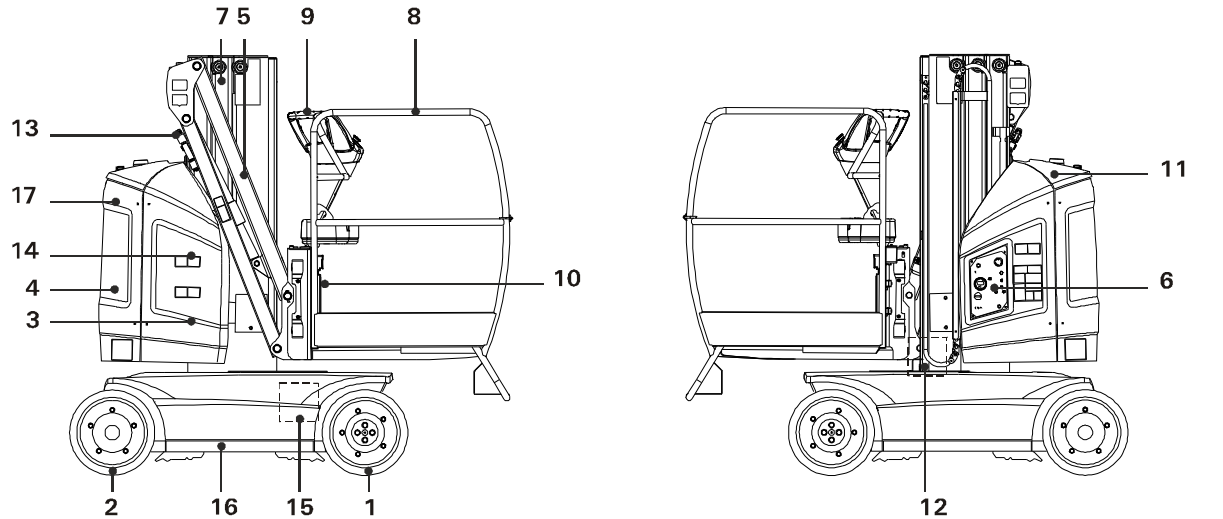

Figure 3-2. Position of Least FORWARD stability

3.5 MACHINE CONTROL LOCATIONS



- | | | |
|---|-------------------------------|--------------------------------------|
| 1- Driving wheels | 7- Telescopic mast | 13- Jib manual descent valve |
| 2- Steering Wheels | 8- Platform | 14- Swinging motor release valve |
| 3- Access door to Pump/Motor Control valves | 9- Platform Control console | 15- Manual swinging operating device |
| 4- Counterweight | 10- Manual Storage Container | 16- Chassis |
| 5- Jib | 11- Access door to battery | 17- Charger |
| 6- Ground Control Panel | 12- Mast manual descent valve | |

Figure 3-3. Basic Nomenclature - Machine Control Locations - 8E

SECTION 3 – MACHINE CONTROLS, INDICATORS AND OPERATION

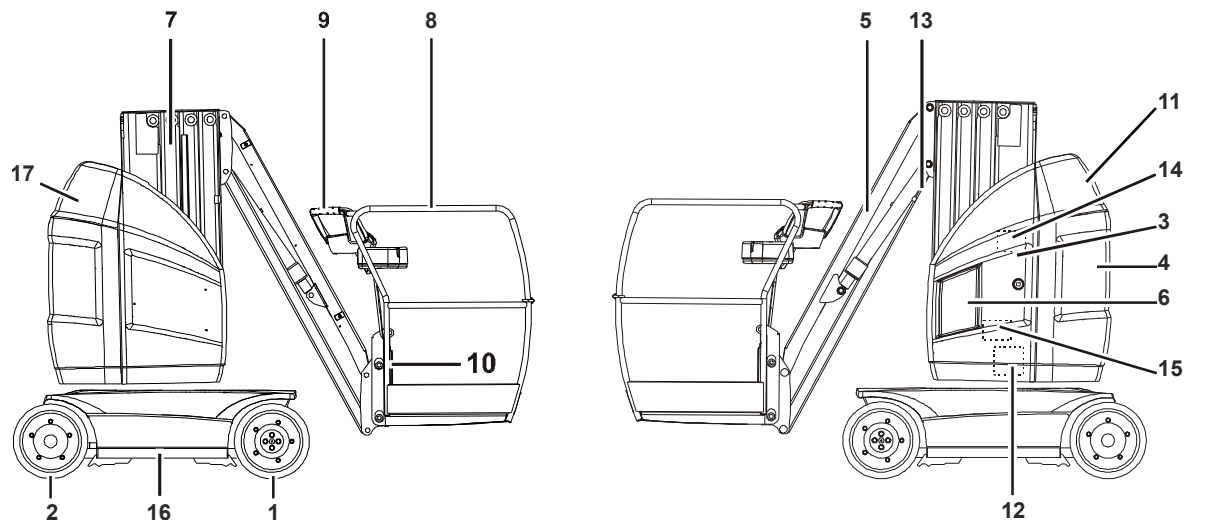

- 1- Driving wheels
- 2- Steering Wheels
- 3- Access door to Pump/Motor Control valves
- 4- Counterweight
- 5- Jib
- 6- Ground Control Panel

- 7- Telescopic mast
- 8- Platform
- 9- Platform Control console
- 10- Manual Storage Container
- 11- Access door to battery/charger
- 12- Mast manual descent valve

- 13- Jib manual descent valve
- 14- Swinging motor release valve
- 15- Manual swinging operating device
- 16- Chassis
- 17- Charger

Figure 3-4. Basic Nomenclature - Machine Control Locations - 10E

3.6 CONTROLS AND INDICATORS

WARNING

TO AVOID SERIOUS INJURY, DO NOT OPERATE MACHINE IF ANY CONTROL LEVERS OR TOGGLE SWITCHES CONTROLLING PLATFORM MOVEMENT DO NOT RETURN TO THE OFF POSITION WHEN RELEASED.

NOTE: *The indicator panels use different shaped symbols to alert the operator to different types of operational situations that could arise. The meaning of those symbols are explained below.*



Indicates a potentially hazardous situation, which if not corrected, could result in serious injury or death. This indicator will be red.



Indicates an abnormal operating condition, which if not corrected, may result in machine interruption or damage. This indicator will be yellow.



Indicates important information regarding the operating condition, i.e. procedures essential for safe operation. This indicator will be green.

3.7 GROUND CONTROL STATION

WARNING

DO NOT OPERATE FROM GROUND CONTROL STATION WITH PERSONNEL IN THE PLATFORM EXCEPT IN AN EMERGENCY.

NOTICE

WHEN THE MACHINE IS SHUT DOWN FOR OVERNIGHT PARKING OR BATTERY CHARGING, THE PLATFORM/OFF/GROUND SELECTOR AND THE EMERGENCY STOP SWITCHES MUST BE POSITIONED TO OFF TO PREVENT DRAINING THE BATTERIES.

SECTION 3 – MACHINE CONTROLS, INDICATORS AND OPERATION

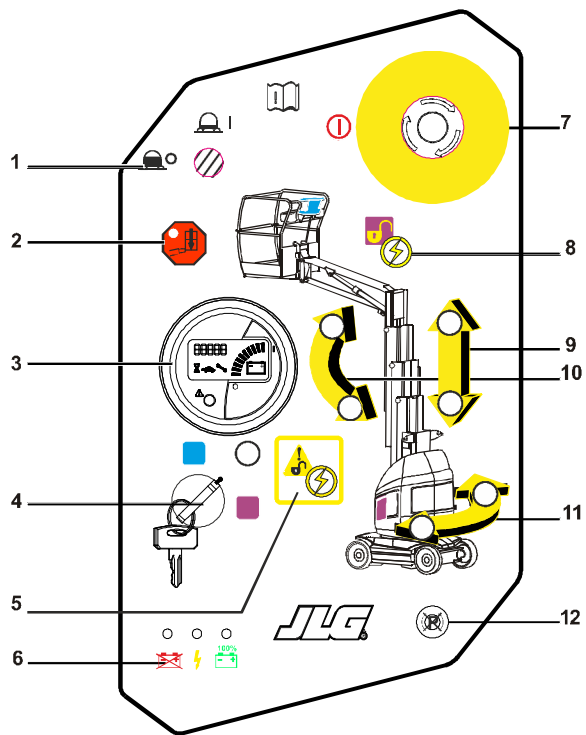

1. 5 Amp Circuit Breaker
2. Overload Warning Light
3. Multi-Display Indicator (MDI)
4. Platform/Off/Ground Selector Switch
5. Machine Safety System Override (MSSO) (If equipped)
6. Battery Charger Status Indicators (depending on equipment)
7. Emergency Stop Switch
8. Function Enable Button
9. Mast Lift/Lower Buttons
10. Jib Lift/Lower Buttons
11. Superstructure Swing Buttons
12. Brake Release Button

Figure 3-5. Ground Control Station

SECTION 3 – MACHINE CONTROLS, INDICATORS AND OPERATION

- 1. 5 Amp. Circuit Breaker** - This circuit breaker protects the control circuit in case of a short circuit or other malfunction.
- 2. Overload Warning Light** - This lamp (red), when blinking, indicates that the maximum rated load in the platform is exceeded. The platform must be safely unloaded until the alarm stops.

3. Multi-Display Indicator (MDI)



Hourmeter - The hourmeter symbol is lit when the number of operated hours is displayed.



Speed reduction - Indicates that the maximum drive speed is reduced when the platform is out of transport position.



The wrench symbol is lit when a DTC (Diagnosis Troubleshooting Code) is displayed.



Five Digits Display

In normal operating condition, displays the total amount of machine operation time accumulated.

In abnormal operating condition, displays a DTC (Diagnosis Troubleshooting Code).



Alarm LED

Illuminates in abnormal operating condition (when a DTC, other than 00xx DTC's exists).

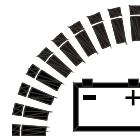

Battery Discharge Indicator (BDI).

This bar-graph is designed to let the operator know the condition of the battery before starting to use the machine.

The last bar flashes when the level of charge is less than 10%. The bar-graph is not displayed when the batteries are completely discharged.

SECTION 3 – MACHINE CONTROLS, INDICATORS AND OPERATION

4. **Platform/Off/Ground Selector Switch** - A three-position, key-operated power select switch supplies power to the platform or ground controls and powers machine down in the off position.
5. **Machine Safety System Override (If equipped) (MSSO)** - Provides emergency override of function controls that are locked out in the event of Load Sense System activation.
6. **Battery Charger Status Indicators (depending on equipment)** - This panel is designed to give the operator an accurate reading on the status of the battery charger. **DEPENDING ON THE CHARGER INSTALLED ON THE MACHINE THESE LIGHTS MAY NOT BE USED. REFER TO SECTION 3-16 OF THIS MANUAL FOR FURTHER INFORMATION.**



GREEN- Charge complete



YELLOW- Charging in process



RED- Charging abnormal

7. **Emergency Stop Switch** - Depress the switch to stop all functions of the machine. The switch must be turned clockwise to restore the machine functions.

8. **Function Enable Button** - A membrane switch that must be pushed in and held to enable the controls of the ground control station.
9. **Mast Lift/Lower Buttons** - Membrane switches that provide raising or lowering of the mast (with the Function Enable Switch (8) pushed in).
10. **Jib Lift/Lower Buttons** - Membrane switches that provide raising or lowering of the jib (with the Function Enable Switch (8) pushed in).
11. **Turntable Swing Buttons** - Membrane switches that provide swinging of the superstructure to the right or to the left (with the Function Enable Switch (8) pushed in).
12. **Brake Release Switch**

⚠ WARNING

DO NOT MANUALLY DISENGAGE THE BRAKES UNLESS THE MACHINE:
- **IS IN TRANSPORT (STOWED) POSITION.**
- **IS ON A SMOOTH, FIRM AND LEVEL SURFACE.**
- **WHEELS CHOCKED OR MACHINE POSITIVELY CONNECTED TO TOW VEHICLE.**

The machine must be powered ON to Ground Control Mode at the Platform/Off/Ground selector switch to operate the brake release switch. Refer to section 3-18 of this manual for further information.

Platform Manual Descent Valves - 8E

The platform manual descent valves are used in the event of total power failure to lower the platform using gravity.

These devices are composed of:

- a mast manual descent valve
- a jib manual descent valve

⚠ WARNING

DO NOT USE THE MANUAL DESCENT CONTROLS IF THE SLACK CHAIN WARNING ALARM IS ACTIVE. REFER TO SECTION 4 FOR SPECIFIC RECOVERY PROCEDURES.

WHEN USING THE MANUAL DESCENT CONTROL, ENSURE THE MAST ELEMENTS ARE LOWERING SYNCHRONOUSLY.

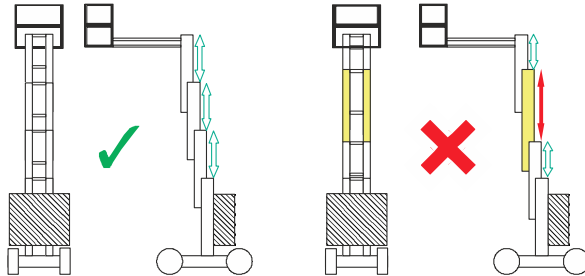

1. To lower the mast:

- a. Install the actuator on the remote pull bar.
- b. Pull on the actuator. Release the actuator when the platform is lowered to the desired level.
- c. Return the actuator to the battery storage compartment after use.

2. To lower the jib once the mast is fully retracted, push in the manual descent valve override button. Release the button when the platform is lowered to the desired level.

⚠ WARNING

KEEP BODY, HANDS AND ARMS OUT OF THE PATH OF THE MAST, THE JIB AND THE PLATFORM WHILE LOWERING.

Mast Manual Descent Valve and Actuator - 8E

- The mast manual descent **valve actuator (1)** is stored behind the access door to the battery.
- The mast manual descent remote **pull bar (2)** is located on the right side of the platform.

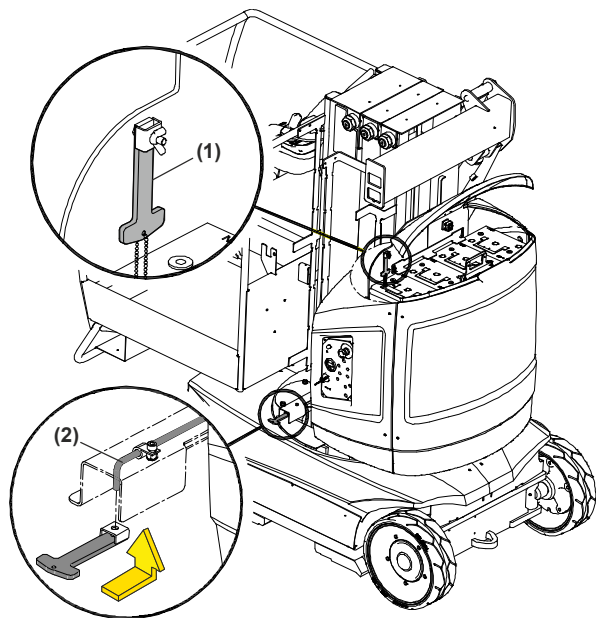

Figure 3-6. Mast Manual Descent Valve - 8E

Jib Manual Descent Valve - 8E

- The jib manual **descent button (3)** is located on the jib cylinder valve.

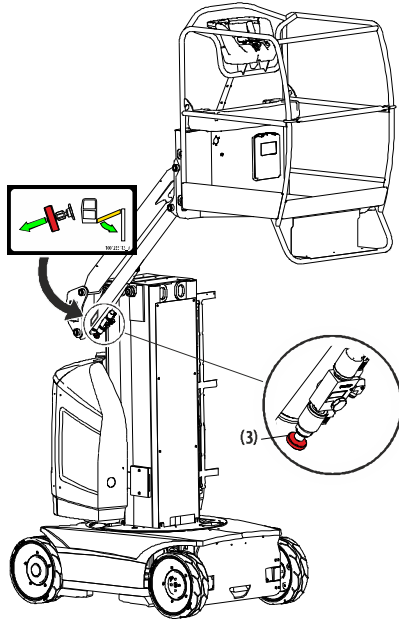

Figure 3-7. Jib Manual Descent Valve - 8E

Manual Swinging Operating Devices - 8E

The manual swinging operating devices are used in the event of total power failure to manually swing the superstructure. Those devices are composed of:

- a **rotary valve (1)** located on the pump/motor control valves assembly to release the swinging motor.

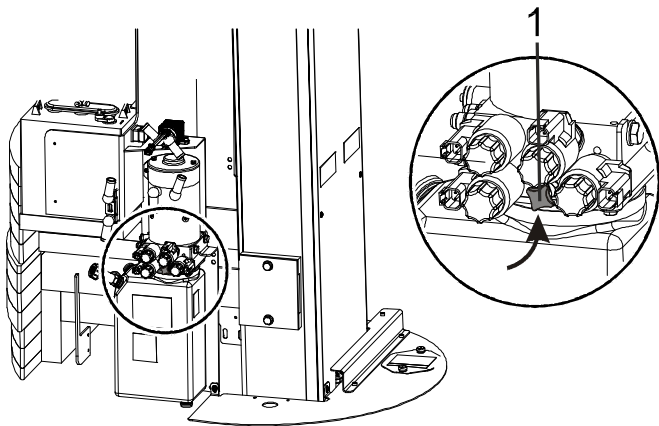

Figure 3-8. Rotary Valve - 8E

- a **solid hand wheel (2)**, located behind the access door.

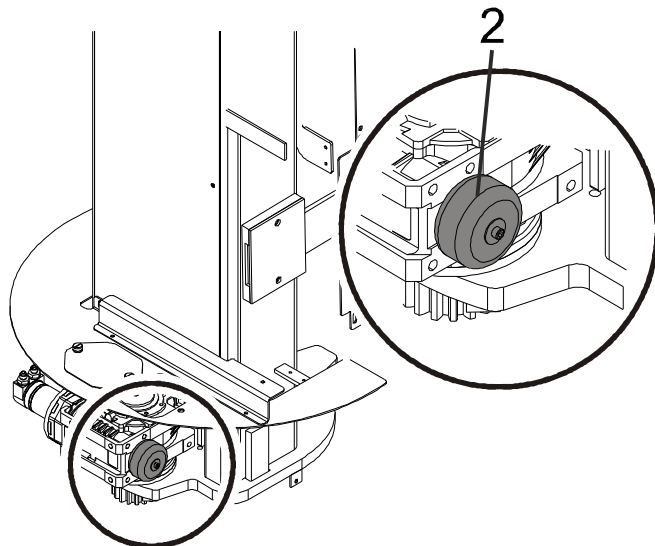

Figure 3-9. Solid Hand Wheel - 8E

WARNING

DO NOT RELEASE THE SWINGING MOTOR UNLESS THE MACHINE IS ON A LEVEL SURFACE.

1. Remove the access door to the pump/motor assembly.
2. Fully unscrew the **rotary valve (1)**.
3. Open the access cover to the operating hand wheel.
4. Turn the **hand wheel (2)** clockwise to swing the structure to the right or turn the hand wheel counter-clockwise to swing the structure to the left.
5. When finished swinging, fully close the rotary valve, close the access cover and reposition the access cover to the pump/motor assembly.

Platform Manual Descent Valves - 10E

The platform manual descent valves are used in the event of total power failure to lower the platform using gravity.

These devices are composed of:

- a mast manual descent valve
- a jib manual descent valve

⚠ WARNING

DO NOT USE THE MANUAL DESCENT CONTROLS IF THE SLACK CHAIN WARNING ALARM IS ACTIVE. REFER TO SECTION 4 FOR SPECIFIC RECOVERY PROCEDURE.

WHEN USING THE MANUAL DESCENT CONTROL, ENSURE THE MAST ELEMENTS ARE LOWERING SYNCHRONOUSLY.

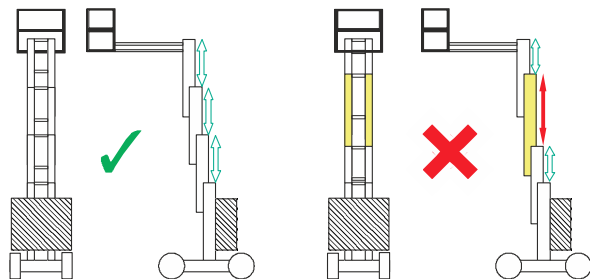

1. To lower the mast:
 - a. Install the actuator on the remote push bar.
 - b. Push on the actuator. Release the actuator when the platform is lowered to the desired level.
 - c. Return the actuator to the battery compartment after use.
2. To lower the jib once the mast is fully retracted, push in the manual descent valve, **override button (3)**. Release the button when the platform is lowered to the desired level.

⚠ WARNING

KEEP BODY, HANDS AND ARMS OUT OF THE PATH OF THE MAST, THE JIB AND THE PLATFORM WHILE LOWERING.

Mast Manual Descent Valve and Actuator - 10E

- The mast manual descent valve **actuator (1)** is stored behind the access door to the battery.
- The mast manual descent valve remote **push bar (2)** is located behind the access door to the pump/motor assembly.

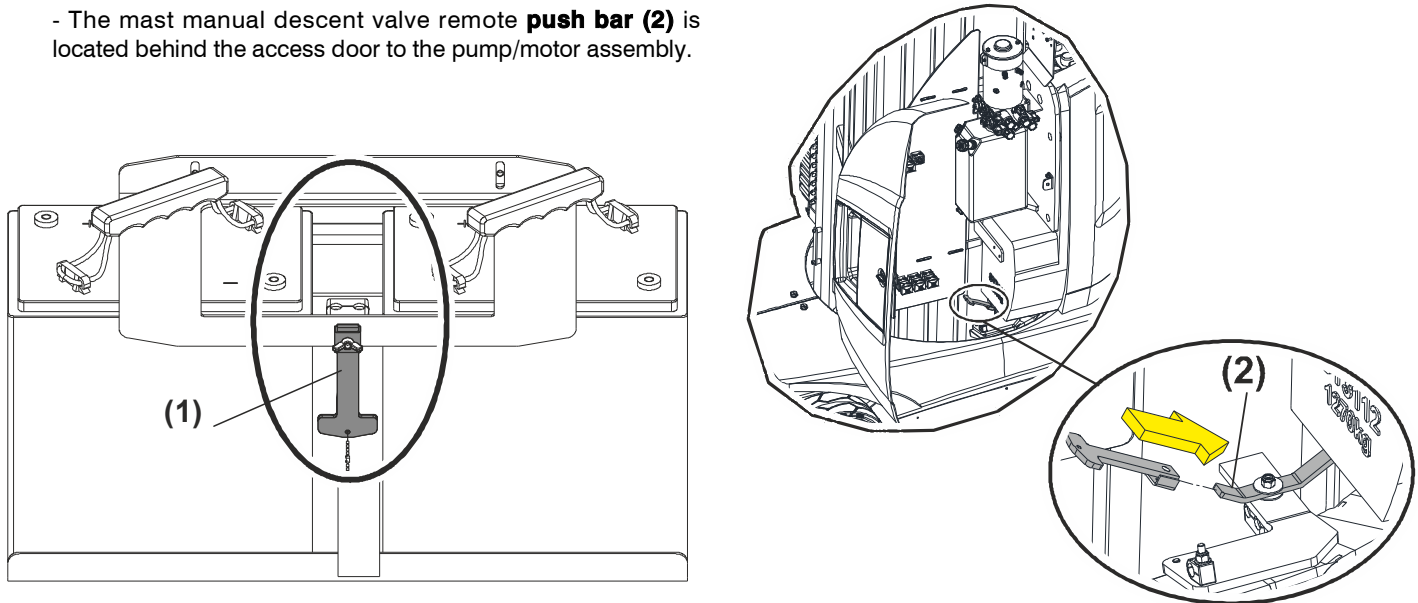

Figure 3-10. Mast Manual Descent Valve - 10E

Jib Manual Descent Valve - 10E

- The jib manual **descent button (3)** is located on the jib cylinder valve.

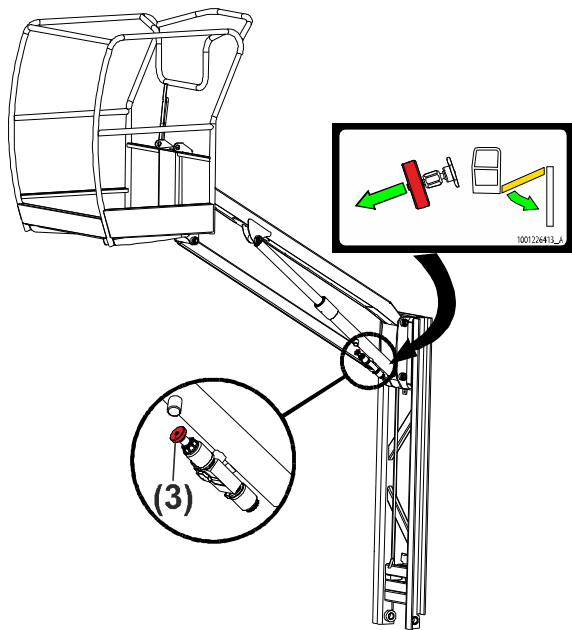

Figure 3-11. Jib Manual Descent Valve - 10E

Manual Swinging Operating Devices - 10E

The manual swinging operating devices are used in the event of total power failure to manually swing the superstructure. Those devices are composed of:

- a **rotary valve (1)** located on the pump/motor control valves assembly to release the swinging motor (Refer to Figure 3-12.).
- a **pinion (2)**, located below the pump/motor control valves compartment, that can be operated using the **folding lever (3)**.

⚠ WARNING

DO NOT RELEASE THE SWINGING MOTOR UNLESS THE MACHINE IS ON A LEVEL SURFACE.

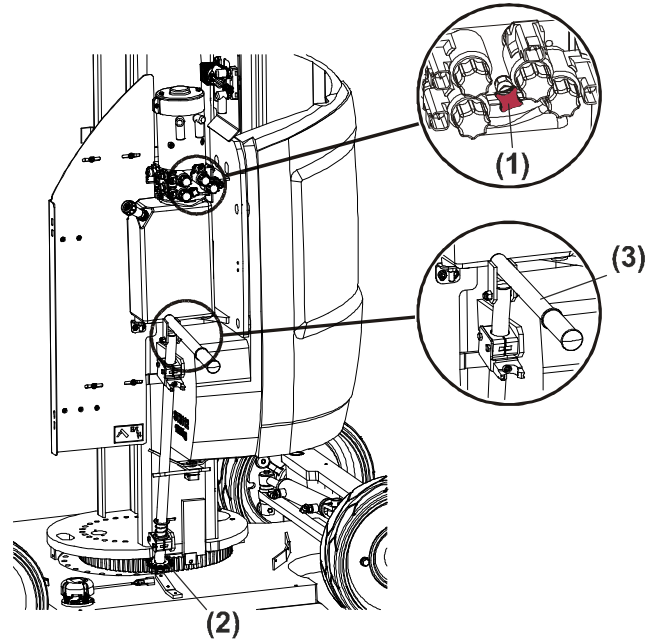

Figure 3-12. Manual Swinging Operating Devices - 10E

SECTION 3 – MACHINE CONTROLS, INDICATORS AND OPERATION

1. Open the access door to the pump/motor assembly.
2. Fully unscrew the rotary valve.
3. Lift the folding lever. Push on top of the pinion to engage it in the turntable bearing teeth. Turn the lever clockwise to swing the structure to the right or turn the lever counter-clockwise to swing the structure to the left.
4. When finished swinging, fold back the lever until it is latched. Fully screw in the rotary valve.

WARNING

NEVER LEAVE THE MACHINE WITH THE LEVER UNFOLDED OR WITH THE ROTARY VALVE UNSCREWED.

3.8 PLATFORM CONTROL STATION

⚠ WARNING

TO AVOID SERIOUS INJURY, DO NOT OPERATE MACHINE IF ANY CONTROL LEVERS OR SWITCHES CONTROLLING PLATFORM MOVEMENT DO NOT RETURN TO THE OFF OR NEUTRAL POSITION WHEN RELEASED.

1. Indicator Panel
2. Emergency Stop Switch
3. Trigger Switch
4. Drive/Swing Functions Controller
5. Steer Switch
6. Function Enable Button
7. Mast Lift Up/Down Joystick Controller
8. Jib Lift Up/Down Joystick Controller
9. Drive Orientation System (DOS) Override Button
10. Horn Button

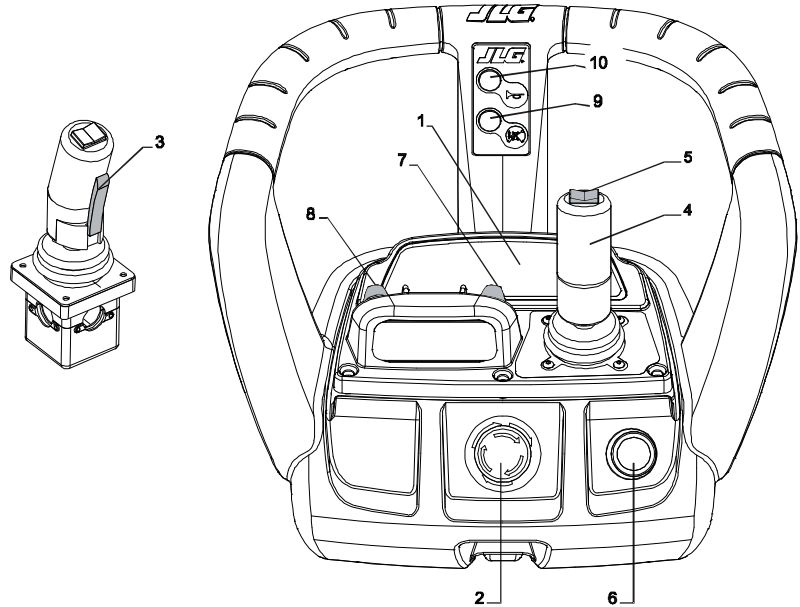

Figure 3-13. Platform Control Station

SECTION 3 – MACHINE CONTROLS, INDICATORS AND OPERATION

1. Indicator Panel

NOTE: The indicator lights will illuminate for approximately 1 second when the key is positioned to the ON position to act as a self test.

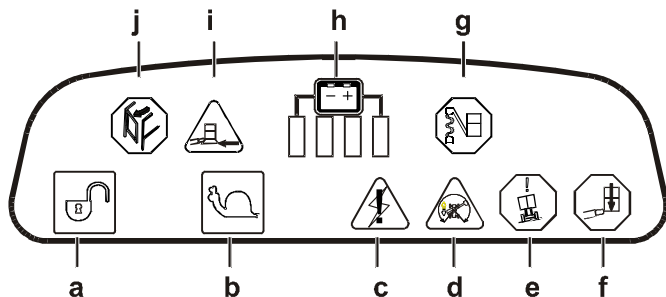
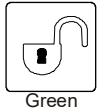

Figure 3-14. Platform Control Indicator Panel

- a-** Control Enable Indicator
- b-** Creep Speed Indicator
- c-** System Distress Indicator
- d-** Drive Orientation Indicator
- e-** Tilt Indicator Warning Light
- f-** Overload Indicator Warning Light
- g-** Slack Chain Indicator Warning Light
- h-** Battery Discharge Indicator (BDI)
- i-** Soft Touch Indicator (If equipped)
- j-** Opening Gate Warning Light (8E: XL Basket only)

SECTION 3 – MACHINE CONTROLS, INDICATORS AND OPERATION



Green

- a.** When lit, indicates that the controls are enabled. If a function is not actuated within seven seconds, or a seven seconds lapse between ending one function and beginning the next function occurs, the enable light will go out and the enable must be released and activated again to enable the controls.

When blinking, indicates that the machine is in a configuration where the current activated function is not permitted.



Green

- b.** Indicates that the high drive cutout limit-speed is engaged (the machine is out of transport (stowed) position).



Yellow

- c.** This light indicates that the control system has detected an abnormal condition. This lamp when actuated is flashing a DTC (Diagnostic Trouble-Shooting Code). For an explanation of these codes and items, the operator can or cannot correct, see Section 5 Diagnostic Trouble Codes (DTC).



Yellow

- d.** When the structure is swung beyond the rear tires or further in either direction, the Drive Orientation indicator will illuminate. This is a signal for the operator to verify that the drive control is being operated in the proper direction (i.e. controls reversed situations).

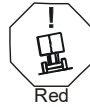

Red

- e.** Indicates that the chassis is out of level (refer to machine specifications for max. allowable slope angle). If the machine is out of the transport (stowed) position and the chassis is out of level, an audible alarm will sound.

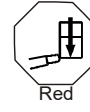

Red

- f.** Indicates that the maximum rated load in the platform is exceeded. In addition to the warning indicator, an audible alarm sounds. The platform must be unloaded until the alarm stops.

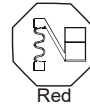

Red

- g.** Indicates that a slack chain condition has been detected. In addition to the warning indicator, an audible alarm will sound as long as the chain slack chain condition exists.



- h.** This set of lights indicates the charge level of the battery.

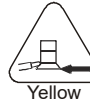

Yellow

- i.** (If equipped) - Indicates the Soft Touch frame is against an obstacle. In addition to the warning indicator, an audible alarm sounds. Once illuminated, only the reverse movement to the one that caused the contact with the obstacle can be operated in Creep mode.



- j.** (8E XL Basket Only) - Indicates that one of the platform gates is open.

SECTION 3 – MACHINE CONTROLS, INDICATORS AND OPERATION

- 2. Emergency Stop Switch** - A two-position, red, emergency stop switch, when positioned to ON furnishes operating power to the platform control station. In addition, the switch can be used to turn off power to the function controls in the event of an emergency. Power is turned off by depressing the switch and power is turned on by turning the switch clockwise to pull it out.
- 3. Trigger Switch** - This switch located at the front of the controller acts as an enable and must be depressed before operating the drive, steer and swinging functions. When released, the function being operated will stop.
- 4. Drive/Swing Functions Controller** - This dual axis joystick controls drive and swinging functions. The speed of both functions is proportionally controlled by the distance of travel of the hand joystick.
Drive - Engage the trigger switch lever (3) with the joystick in neutral position then move the control handle forward to drive the machine forward or move the control handle backward to drive the machine backward.
Swing - Engage the trigger switch lever (3) with the joystick in neutral position then toggle the control handle to the left to swing the superstructure to the left or toggle the control handle to the right to swing to the right.
- 5. Steer Switch** - The thumb-operated steer switch on top of the control handle activates the steer wheels in the direction activated (right or left).
- 6. Function Enable Button** - This button is used to enable mast and jib functions. It must be depressed and held before actuating a mast or a jib function. When released, the function being operated will stop.
- 7. Mast Lift Up/Down Joystick Controller** - This fingertip, single axis, joystick controller operates Mast Lift Up and Lift Down functions.
With the joystick controller in neutral position, push-in and hold the Function Enable Button (6), moving the joystick Up will raise the mast and moving the joystick Down will lower the mast. The speed of the movements is proportionally controlled by the distance of travel of the joystick.
- 8. Jib Lift Up/Down Joystick Controller** - This fingertip, single axis, joystick controller operates jib Lift Up and jib Lift Down functions.
With the joystick controller in neutral position, push-in and hold the Function Enable Button (6), moving the joystick Up will raise the jib and moving the joystick Down will lower the jib. The speed of the movements is proportionally controlled by the distance of travel of the joystick.
- 9. Drive Orientation Override Button** - When the jib is swung beyond the rear tires or further in either direction, the Drive Orientation indicator will illuminate. Before driving, locate the black/white orientation arrows on both

the chassis and the platform controls. Push and release the override switch and within 3 seconds slowly move the Drive/Steer control to actuate drive or steer. Move the drive control toward the arrow matching the intended direction of machine travel.

- 10. Horn** - This button, when activated, permits the operator to warn job site personnel when the machine is operating in the area.

Grade and Side Slope

See Figure 3-15., Grade and Side Slope

NOTE: Refer to the Operating Specifications table for Gradeability and Sideslope ratings.

With the machine in transport mode, travelling is limited by two factors: gradeability and side slope. Gradeability is the percent of grade of the incline the machine can climb. Side slope is the angle of the surface the machine can be driven across. Refer to Table 5-1.

When the machine is out of transport (stowed) position, the machine must not be operated on grade or side slopes greater than that is specified in Table 5-1.

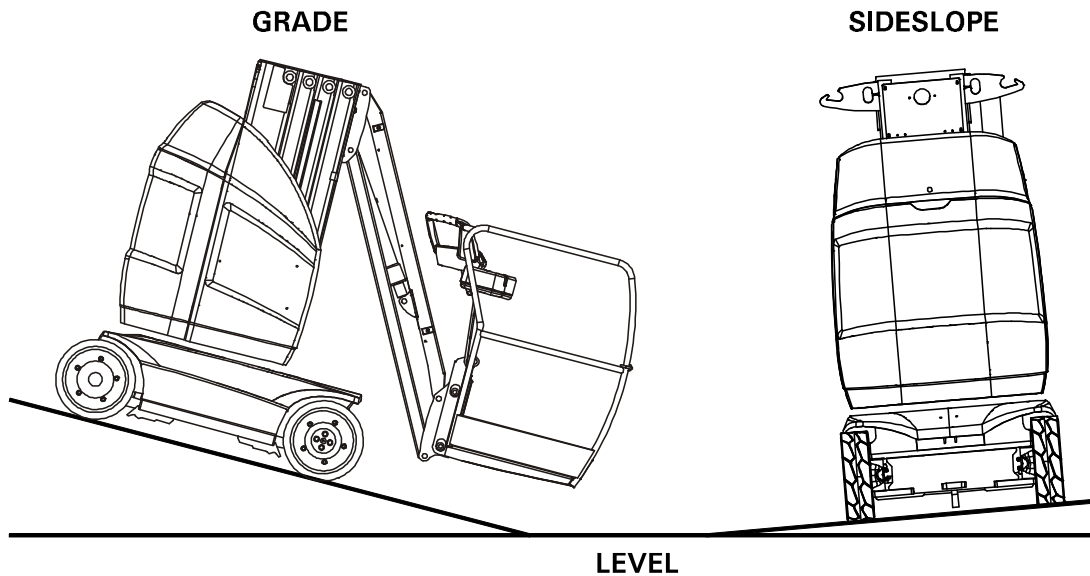

Figure 3-15. Grade and Side Slope

3.9 OPERATION

1. At ground control station, position the key-select switch to PLATFORM.
2. Position the emergency stop switch to the on (out) position by turning it clockwise.
3. At platform control station, position the emergency stop switch to the on (out) position by turning it clockwise.

NOTE: *If at any time during operation, the machine remains idle for a period exceeding 2 hours, machine power will be shut down. The emergency stop switch(es) must be recycled to start machine again.*

⚠ WARNING

TO AVOID SERIOUS INJURY, DO NOT OPERATE MACHINE IF ANY CONTROL LEVERS OR SWITCHES CONTROLLING THE PLATFORM MOVEMENT DOES NOT RETURN TO THE OFF OR NEUTRAL POSITION WHEN RELEASED.

IF THE PLATFORM DOES NOT STOP WHEN CONTROL LEVER OR THE ENABLE BUTTON/TRIGGER SWITCH IS RELEASED, USE THE EMERGENCY STOP SWITCH TO STOP THE MACHINE.

3.10 STEERING AND TRAVELLING (DRIVING)

⚠ WARNING

DO NOT DRIVE WITH MAST OR JIB OUT OF TRANSPORT (STOWED) POSITION EXCEPT ON A SMOOTH, FIRM AND LEVEL SURFACE FREE OF OBSTRUCTIONS AND HOLES.

TO AVOID LOSS OF TRAVEL CONTROL OR "TIP OVER", DO NOT DRIVE MACHINE ON GRADES OR SIDE SLOPES EXCEEDING THOSE SPECIFIED IN SECTION 5.

USE EXTREME CAUTION WHEN DRIVING IN REVERSE AND AT ALL TIMES WHEN THE PLATFORM IS ELEVATED.

BEFORE DRIVING, LOCATE THE BLACK/WHITE ORIENTATION ARROWS ON BOTH THE CHASSIS AND THE PLATFORM CONTROLS. MOVE THE DRIVE CONTROLS IN A DIRECTION MATCHING THE DIRECTIONAL ARROW FOR THE INTENDED DIRECTION OF TRAVEL.

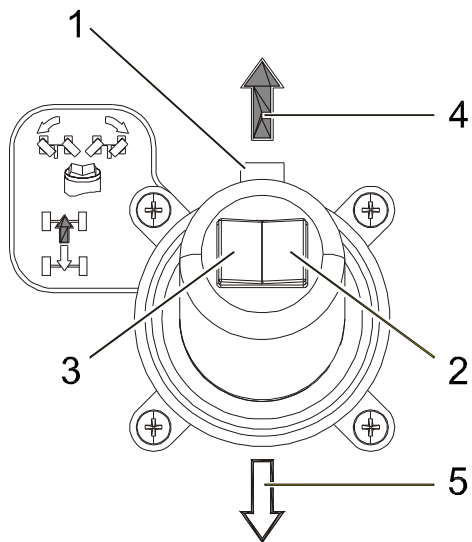

Figure 3-16. Steer/Drive Controls

Steering

1. Squeeze and hold the **trigger switch (1)** on front of the joystick.
2. Activate the thumb switch on top of the joystick to **right (2)** for travelling right or to **left (3)** for travelling left. When released, the thumb switch will return to the center-off position and the wheels will remain in the previously selected position. To return the wheels to the straightened position, the switch must be activated in the opposite direction until the wheels are centered.

Travelling (driving)

1. With all control levers in neutral position, squeeze and hold the **trigger switch (1)** on front of the joystick.
2. Move the joystick **forward (4)** (within 7 seconds after the trigger has been actuated) to drive forward or move the joystick **backward (5)** to drive in reverse. The speed of the movement is proportionally controlled by the distance of travel of the joystick.
3. Return the controller to its centered (neutral) position to stop, then release the trigger.

⚠ WARNING

IF THE TILT INDICATOR WARNING LIGHT/ALARM IS ACTIVATED WHILE DRIVING WITH THE MAST RAISED, LOWER THE MAST COMPLETELY AND DRIVE TO A SMOOTH, FIRM AND LEVEL SURFACE.

Drive Orientation System (DOS)

When the structure is swung beyond the rear wheels or further in either direction, the **drive orientation indicator (1)** will illuminate and drive will be disabled.

1. Push and release the **override button (2)**, and within 3 seconds move the drive/steer controls to activate drive or steer.
2. Before driving, locate the black/white directional arrows on both the chassis and the platform controls (3). Move the drive control joystick in a direction matching the directional arrow, for the intended direction of travel.

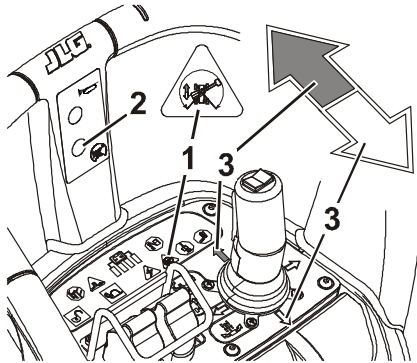

Figure 3-17. Drive Orientation System (DOS)

3.11 RAISING AND LOWERING THE PLATFORM

WARNING

DO NOT RAISE THE PLATFORM EXCEPT ON A SMOOTH, FIRM AND LEVEL SURFACE FREE OF OBSTRUCTIONS AND HAZARDS. ENSURE THE AREA BENEATH THE PLATFORM IS FREE FROM PERSONNEL PRIOR TO LOWERING THE PLATFORM.

Raising and lowering the mast

1. With all control levers in neutral position, push in and hold the **Function Enable Button**.
2. To raise or lower the mast, move the mast controller in the desired movement direction. The speed of the movement is proportionally controlled by the distance of travel of the joystick.
3. Return the controller to its centered (neutral) position to stop.

Raising and lowering the jib

1. With all control levers in neutral position, push in and hold the **Function Enable Button**.
2. To raise or lower the jib, move the jib controller in the desired movement direction. The speed of the movement is proportionally controlled by the distance of travel of the joystick.
3. Return the controller to its centered (neutral) position to stop.

3.12 SWINGING

WARNING

DO NOT SWING THE SUPERSTRUCTURE EXCEPT ON A SMOOTH, FIRM AND LEVEL SURFACE, FREE OF OBSTRUCTIONS AND HOLES.

CAUTION

WHEN SWINGING, MAKE SURE THERE IS AMPLE ROOM FOR THE JIB TO CLEAR SURROUNDING WALLS, PARTITIONS AND EQUIPMENT.

1. With all control levers in neutral position, squeeze and hold the **trigger switch** on front of the joystick.
2. Move the joystick to the desired direction: **right** or **left**. The speed of the movement is proportionally controlled by the distance of travel of the joystick.
3. Return the controller to its centered (neutral) position to stop, then release the trigger.

3.13 ALARMS

Overload Warning Light/Alarm

When the maximum rated load in the platform is exceeded, RED light indicators at both the ground and the platform control stations will blink and an audible alarm will sound. When the overload indicator warning is activated, all machine functions are disabled. The platform must be safely unloaded until the alarm stops.

Tilt Warning Light/Alarm

When the chassis is out of level (Refer to Table 5-1), the RED light indicator at platform control station will illuminate. If the machine is out of transport (stowed) position, and the chassis is out of level an audible alarm will sound.

WARNING

TO AVOID TIP OVER IF RED TILT WARNING LIGHT LIGHTS WHEN MACHINE IS OUT OF TRANSPORT POSITION, LOWER THE PLATFORM TO GROUND LEVEL. THEN REPOSITION MACHINE SO THAT CHASSIS IS LEVEL BEFORE RAISING JIB.

SECTION 3 – MACHINE CONTROLS, INDICATORS AND OPERATION

When the tilt indicator warning is activated, the following functions are affected:

- The Drive function is disabled out of stowed position.
- Mast/Jib Lift and Swinging movements switch to Creep mode out of transport position.
- Mast Lift Up is disabled in stowed position.
- The retraction functions properly.

When the tilt indicator warning is activated, control the machine as follows:

1. Lower the mast.
2. Return the platform in line with the chassis.
3. Lower the jib.
4. Drive the machine to a smooth, firm and level surface.

WARNING

AVOID RAISING THE MAST, OPERATING THE JIB OR SWINGING WITH THE MAST RAISED WHEN THE MACHINE IS OUT OF LEVEL. ALWAYS LOWER THE MAST AS MUCH AS POSSIBLE BEFORE OPERATING THE JIB OR SWINGING.

Slack Chain Warning Light/Alarm

When the system detects a slack chain condition, the RED light indicator at platform control station will illuminate and an audible alarm will sound.

Slack chain condition is generally caused by the platform or the jib coming to rest on an obstacle while lowering. When the slack chain indicator warning is activated, all machine functions, except mast and jib raising movements are disabled.

Procedure to follow in case the slack chain indicator warning is activated:

1. Raise the mast or the jib (generally the reverse movement to the one that caused the alarm to be activated). This will re-tension the chain(s) and stop the alarm.
2. Examine surroundings to identify the cause.
3. Perform the movement which will clear the machine and prevent contact with the obstacle.

If the examination of the surroundings does not reveal any possible obstacle, the alarm may have been triggered by the telescopic mast jamming which could be due to:

- A foreign body entering the guiding system.
- An incorrect play (see the Service Manual).

⚠ WARNING

**IF THE SLACK CHAIN ALARM HAS BEEN TRIGGERED BY THE MAST JAMMING, FAILURE TO RESPECT THE PROCEDURES BELOW CAN CAUSE SERIOUS INJURIES.
DO NOT USE MANUAL DESCENT CONTROLS.**

Once it has been determined that the slack chain is not due to the platform resting on an obstacle, proceed in the following manner:

- If the alarm is still active and if safe to do so, raise the mast slightly above previous position to deactivate it (and tension the chains).
- Slew the superstructure so the jib can be lowered.
- Lower the jib.
- Try again to lower the mast.
- If the alarm is no longer actuated: fully lower the mast and get qualified personnel to inspect the machine before it is used again.
- If the mast has not released itself or if the alarm is still actuated, appropriate equipment can be used to remove platform occupants and stabilize motion of the machine.

⚠ WARNING

**IF THE SELF RESCUE PROCEDURE FAILED, DISCONTINUE OPERATION IMMEDIATELY.
DO NOT USE MANUAL DESCENT CONTROLS.**

PLATFORM OCCUPANTS MUST BE RESCUED AND THE MAST MECHANISM SERVICED BY A QUALIFIED TECHNICIAN.

Gate Opening Warning Light (8E XL Basket Only) 

When one of the side gates is open, the RED warning indicator on the platform control console lights. All functions are disabled. Close the gates to resume normal machine operation.

⚠ WARNING

SIDE GATES MUST NOT BE USED AS A MEANS FOR ACCESS TO AND EGRESS FROM THE PLATFORM.

3.14 MACHINE SAFETY SYSTEM OVERRIDE (MSSO) (IF EQUIPPED)

The Machine Safety System Override (MSSO) is used to override function controls for Emergency Platform Retrieval only. Refer to Section 4-7, Machine Safety System Override (MSSO) for operating procedures.

3.15 SHUT DOWN AND PARK

Shut down and park the machine as follows:

- 1.** Drive the machine to a reasonably well-protected and well-ventilated area.
- 2.** Ensure the platform is fully lowered.
- 3.** Turn the platform/ground selector switch to off and remove the key to disable the machine and prevent unauthorized use.
- 4.** At the ground control station, position the emergency stop switch to the off (pushed in) position.
- 5.** If necessary, cover the platform console, the instruction placards, caution and warning decals so that they will be protected from hostile environment.
- 6.** If necessary, charge the battery.

3.16 BATTERY CHARGING

NOTE: Be sure that the machine is parked in a well-ventilated area before charging begins.

⚠ WARNING

ONLY PLUG THE CHARGER INTO A PROPERLY INSTALLED AND GROUNDED OUTLET. DO NOT USE GROUND ADAPTORS OR MODIFY PLUG. DO NOT TOUCH NON-INSULATED PORTION OF OUTPUT CONNECTOR OR NON-INSULATED BATTERY TERMINAL. DO NOT OPERATE CHARGER IF THE AC SUPPLY CORD IS DAMAGED OR IF THE CHARGER HAS RECEIVED A SHARP BLOW, BEEN DROPPED OR OTHERWISE DAMAGED IN ANY WAY. ALWAYS DISCONNECT THE AC SUPPLY BEFORE MAKING OR BREAKING THE (POS/NEG) CONNECTIONS TO THE BATTERY. DO NOT OPEN OR DISASSEMBLE CHARGER.

The battery charger **AC Input plug (1)** is located in the battery compartment, under the access door.

1. Connect the **AC input plug (1)** to a grounded outlet.

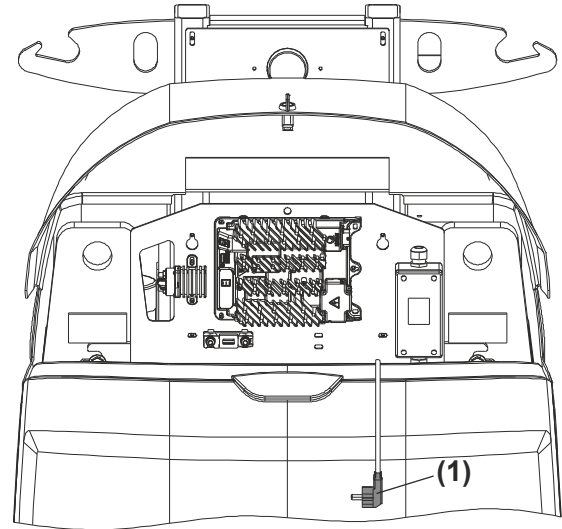





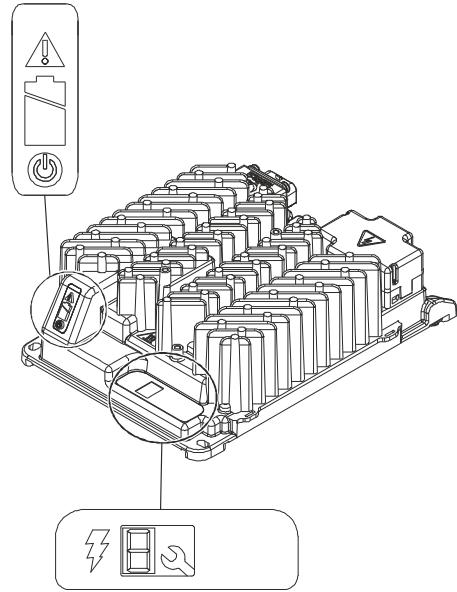

2. When powered up, the charger will go through a short self-test and automatically start the charge.
3. The batteries are fully charged when the battery charging indicator is solid green (See Charger Interface).

SECTION 3 – MACHINE CONTROLS, INDICATORS AND OPERATION

NOTE: *If the charger is left plugged in, the charger will automatically restart a complete charge cycle if the batteries voltage drops below 24.96 V or 30 days has elapsed.*

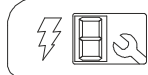
Charger Interface

Status Bar		Status Bar	Display panel	
	Fault Error / USB Indicator Solid red = Charge fault See display panel for details			
	Flashing amber = External error condition - caution See display panel for details			
	Flashing green = USB port active Solid green = Safe to remove USB flash drive			
	Battery Charging Indicator Flashing green = Low state of charge Solid green = High state of charge			
	Battery Charging Indicator Flashing green = High state of charge Solid green = charge complete	Display Panel		

SECTION 3 – MACHINE CONTROLS, INDICATORS AND OPERATION

Troubleshooting

The IC650 Charger is continuously monitoring itself and its environment for unusual conditions. There are a few indications that may require the user's attention.

Symptom	Recommended Action
No indicator lights	Check AC power and connection to batteries
Flashing red Fault/ Error/ USB Indicator	Read fault code (e.g. F-0-0-1) number on the Charge Profile / Error Display and refer to the fault code table below
Flashing amber Fault/ Error/ USB Indicator	Read error code (e.g. E-0-0-1) number on the Charge Profile / Error Display and refer to the error code table below

Charger Fault Codes

Code	Description	Solution
F-0-0-1 F-0-0-2 F-0-0-3 F-0-0-4 F-0-0-6		Internal charger fault. Remove AC and battery for minimum 30 seconds and retry charger. If it fails again, contact your Distributor / Product Support.

SECTION 3 – MACHINE CONTROLS, INDICATORS AND OPERATION

Charger Error Codes		
Code	Description	Solution
E-0-0-1 E-0-2-1	Battery high voltage	Check the battery voltage and cable connections. Check battery size and condition. This error will automatically clear once the condition has been corrected.
E-0-0-2 E-0-2-2	Battery low voltage	Check the battery voltage and cable connections. Check battery size and condition. This error will automatically clear once the condition has been corrected.
E-0-0-3	Charge timeout caused by battery pack not reaching required voltage within safe time limit.	Possible causes: Charger output reduced due to high temperatures, poor battery health, very deeply discharged battery and/or poorly connected battery. Possible solutions: Operate at lower ambient temperature. Replace battery pack. Check DC connections. This error will automatically clear once the charger is reset by cycling DC.
E-0-0-4	Battery could not meet minimum voltage	Check for shorted or damaged cells. Replace battery pack. Check DC connections. This error will automatically clear once the charger is reset by cycling DC.
E-0-0-7	Battery amp hour limit exceeded	Possible causes include poor battery health, very deeply discharged battery, poorly connected battery, and/or high parasitic loads on battery while charging. Possible solutions: Replace battery pack. Check DC connections. Disconnect parasitic loads. This error will automatically clear once the charger is reset by cycling DC.

SECTION 3 – MACHINE CONTROLS, INDICATORS AND OPERATION

E-0-0-8	Battery temperature is out of range	Possible battery temperature sensor error. Check temperature sensor and connections. Reset charger. This error will automatically clear once the condition has been corrected.
E-0-1-1	Charger is disabled by external command	This error will only appear in the charger's log files, not on the user interface. It indicates that the charger has been disabled by an external controller over the CAN bus network (Comm configuration only).
E-0-1-2	Reverse polarity error	Battery is connected to the charger incorrectly. Check the battery connections. This error will automatically clear once the condition has been corrected.
E-0-1-6 E-0-1-8 E-0-2-6	USB operation failed	Software upgrade failure or script operation failure. Ensure the USB flash drive is properly formatted and retry inserting the USB flash drive into the charger.
E-0-1-7	USB operation failed	Remove and reinsert the USB drive. If condition persists, cycle AC and retry by reinserting the USB drive.
E-0-1-9	Hardware does not support software	The charger does not support the new software version. Contact your Distributor / Product Support.
E-0-2-3	High AC voltage error (>270VAC)	Connect charger to an AC source that provides stable AC between 85 - 270 VAC / 45-65 Hz. This error will automatically clear once the condition has been corrected.
E-0-2-4	Charger failed to initialize	The charger has failed to turn on properly. Disconnect AC input and battery for 30 seconds before retrying.

SECTION 3 – MACHINE CONTROLS, INDICATORS AND OPERATION

E-0-2-5	Low AC voltage oscillation error	AC source is unstable. Could be caused by undersized generator and/or severely undersized input cables. Connect charger to an AC source that provides stable AC between 85 - 270 VAC / 45-65 Hz. This error will automatically clear once the condition has been corrected.
E-0-2-7	USB overcurrent fault	USB hardware overcurrent protection has been tripped. Remove and reinsert USB flash drive. If condition persists, try using a different USB flash drive.
E-0-2-8	Charge profile incompatibility	The selected charge profile is incompatible with the charger's software. Update charger software or select a different charge profile.
E-0-2-9	CAN Bus error	Check the physical CAN connector, electrical bus conditions and other CAN modules for correct functioning (Comm configuration only).
E-0-3-0	Comm battery module error	Check the CAN bus battery module for correct functioning (Comm configuration only).
E-0-3-1	Internal charger error	Remove AC and battery for a minimum of 30 seconds and retry charger. If the problem persists, contact your Distributor / Product Support.

3.17 TIE-DOWN/LIFT LUGS

Tie Down

When transporting the machine:

- Platform must be fully lowered in the stowed position.
- Remove all loose items from the machine.
- Machine must be tied down to the truck bed or trailer deck as shown in Figure 3-18. (8E) or Figure 3-19. (10E)

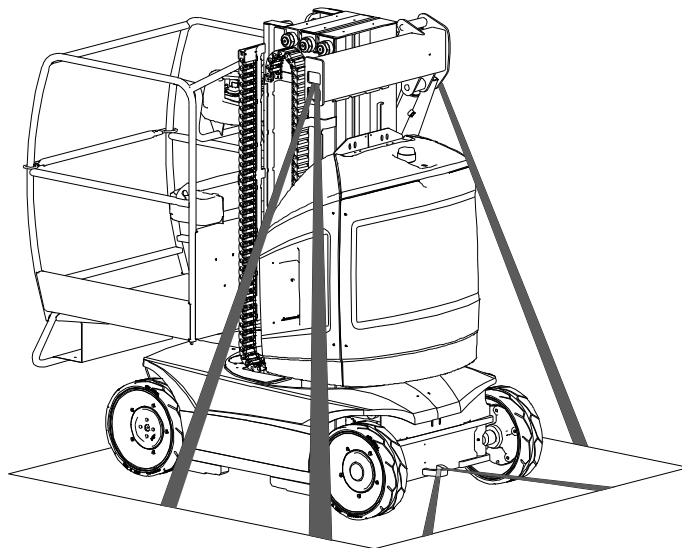
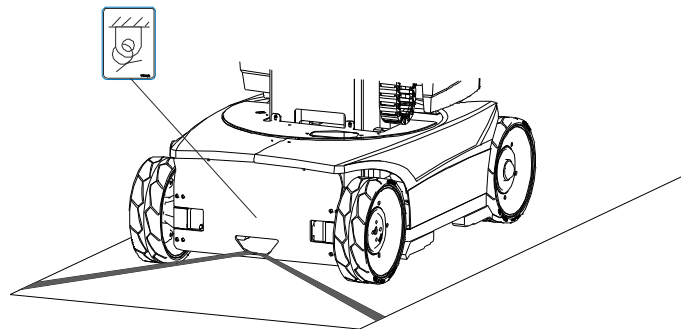

Figure 3-18. Machine Tie-Down - 8E

SECTION 3 – MACHINE CONTROLS, INDICATORS AND OPERATION

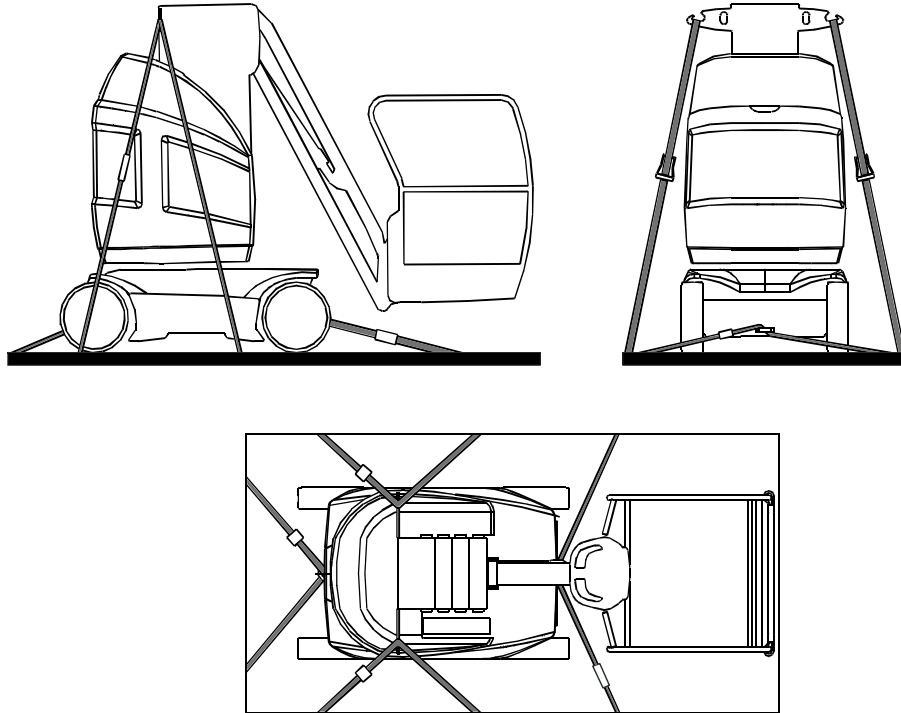

Figure 3-19. Machine Tie-Down - 10E

SECTION 3 – MACHINE CONTROLS, INDICATORS AND OPERATION

Lifting

When lifting the machine:

- Platform must be fully lowered in the stowed position.
- Remove all loose items from the machine.
- Attach lifting straps/chains at BOTH lifting lugs as shown in Figure 3-20.

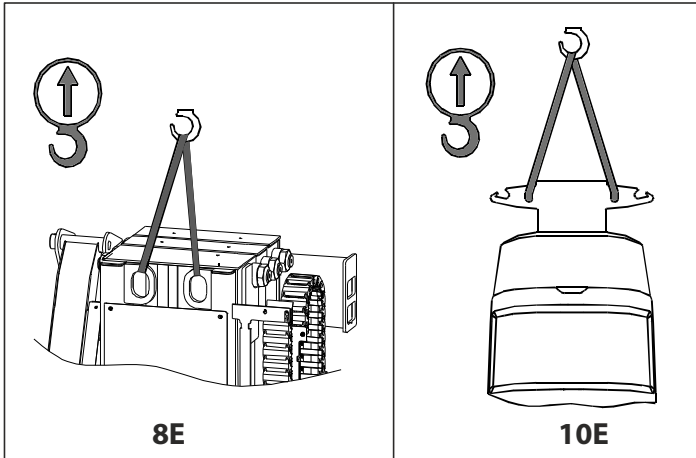

Figure 3-20. Lifting the Machine

The machine may also be lifted using a fork truck:

- Fully lower the mast and the jib.
- Position the platform in line with the chassis with the jib over the rear axle.
- Fork lift as shown in Figure 3-21.

⚠ WARNING

VERIFY THE CAPACITY OF THE FORK TRUCK AND OF ITS EQUIPMENT. FORK LIFT ONLY AT THE DESIGNATED POINTS. WHEN DRIVING THE FORK TRUCK, KEEP THE WORK PLATFORM AS NEAR TO THE GROUND AS POSSIBLE (BUT WITH A SUFFICIENT CLEARANCE FOR THE WHEELS NOT TO CONTACT THE GROUND).

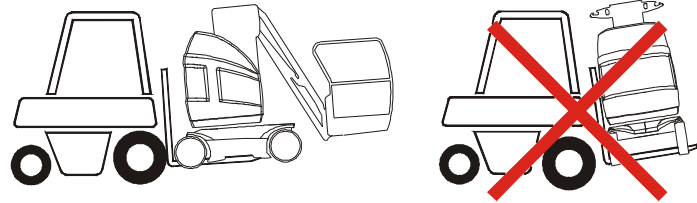

Figure 3-21. Lifting the Machine Using a Fork Truck

3.18 TOWING

It is not recommended that this machine be towed, except in the event of an emergency or a machine power failure.

NOTICE

THE ALLOWABLE TOWING SPEED IS 3 KM/H (1.9 MPH). THE MAXIMUM ALLOWABLE TOWING DISTANCE IS 500 M (0.3 MILES).

Electric Brake Release

NOTE: Electrical release of the brakes requires enough battery power to hold the brakes in released mode until destination is reached.

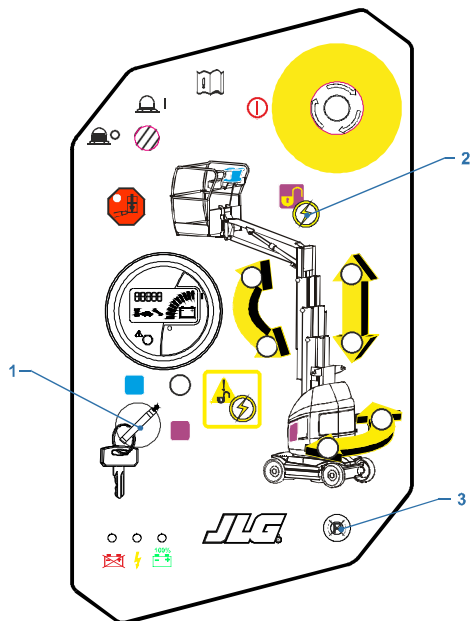

Figure 3-22. Electric Brake Release

1. Chock wheels or secure machine with tow vehicle.
2. Position the key-select-switch to **ground control station (1)**.
3. Push and hold the **enable push button (2)**.
4. Depress the **brake release button (3)** for one second to release the brakes. Once the brakes are released, an acoustic (discontinuous sound) alarm is triggered.
5. When finished towing depress and hold both the **enable push button (2)** and the **brake release button (3)** again or power the machine down at the ground control station to re-engage the brakes.

NOTE: Any action to remove electrical power from the brakes such as, depressing the ground control emergency stop switch, or switching the key switch to OFF or PLATFORM MODE will re-engage the brakes.

SECTION 4. EMERGENCY PROCEDURES

4.1 GENERAL INFORMATION

This section explains the steps to be taken in case of an emergency situation during operation.

4.2 EMERGENCY OPERATION

Operator Unable to Control Machine

IF THE PLATFORM OPERATOR IS UNABLE TO OPERATE OR CONTROL THE MACHINE:

1. Other personnel should operate the machine from ground controls only as required.
2. Only qualified personnel in the platform may use the platform controls. **DO NOT CONTINUE OPERATION IF CONTROLS DO NOT FUNCTION PROPERLY.**
3. Rescue equipment can be used to remove the platform occupant(s). Cranes and forklift can be used to stabilize motion of the machine.

Platform or Jib Caught Overhead

If the platform or the jib becomes jammed or snagged in overhead structures or equipment, rescue the platform occupant(s) prior to freeing the machine.

4.3 EMERGENCY CONTROL

The machine has a Ground Control Station which will override the Platform Control Station. Ground controls operate Lift and Swing, and are to be used in an emergency to lower the platform to the ground, should the operator in the platform be unable to do so.

WARNING

DO NOT OPERATE FROM GROUND CONTROL STATION WITH PERSONNEL IN THE PLATFORM EXCEPT IN AN EMERGENCY. ENSURE THE AREA BENEATH THE PLATFORM IS FREE OF PERSONNEL OR OBSTACLES PRIOR TO LOWERING.

SECTION 4 – EMERGENCY PROCEDURES

1. Position the **key-select switch (1)** to GROUND.
2. Push and hold the **enable button (2)**.
3. Actuate the appropriate **function button (3)** until the desired elevation or position of the platform is achieved.

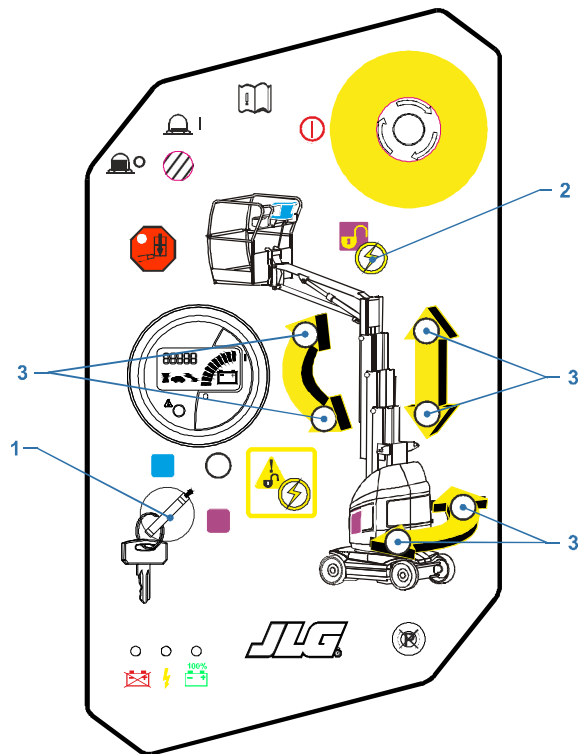

Figure 4-1. Emergency Controls

4.4 PLATFORM MANUAL DESCENT

The platform manual descent valves are used in the event of a total power failure to retract and lower the platform using gravity. Refer to Section 3 PLATFORM MANUAL DESCENT.

4.5 INCIDENT NOTIFICATION

JLG Industries, Inc. must be notified immediately of any incident involving a JLG product. Even if no injury or property damage is evident, the factory should be contacted by telephone and provided with all necessary details.

In USA:

JLG Phone: 877-JLG-SAFE (554-7233)

EUROPE: (44) 1 698 811005

AUSTRALIA: (61) 2 65 811111

E-mail: ProductSafety@JLG.com

Failure to notify the manufacturer of an incident involving a JLG Industries product within 48 hours of such an occurrence may void any warranty consideration on that particular machine.

NOTICE

FOLLOWING ANY INCIDENT, THOROUGHLY INSPECT THE MACHINE AND TEST ALL FUNCTIONS FIRST FROM THE GROUND CONTROLS. DO NOT LIFT ABOVE 3 M (10 FT) UNTIL YOU ARE SURE THAT ALL DAMAGE HAS BEEN REPAIRED, IF REQUIRED, AND TEST ALL CONTROLS ARE OPERATING CORRECTLY.

4.6 EMERGENCY TOWING

Towing this machine is discouraged. However provisions for towing the machine in emergency situations have been incorporated. Refer to Section 3-18 TOWING.

4.7 MACHINE SAFETY SYSTEM OVERRIDE (MSSO) (IF EQUIPPED)

The Machine Safety System Override (MSSO) is only to be used to retrieve an operator that is pinned, trapped, or unable to operate the machine and function controls are locked out from the platform due to a platform overload situation.



NOTE: *If the MSSO functionality is used, the fault indicator will flash and a fault code is set in the JLG Control System which must be reset by a qualified JLG Service Technician.*

NOTE: *No functional checks of the MSSO system are necessary. The JLG Control System will set a Diagnostic Trouble Code if the control switch is faulty.*

To operate the MSSO:

1. From the ground control console, place the Platform/ Ground Select switch in the Ground position.
2. Pull out the Power/Emergency Stop control.
3. Press and hold the MSSO switch and the control switch for the desired function.
Alternate MSSO activation:
Press three times the Ground Enable Push button within 1.5 seconds, hold the third press and push on a button for the desired function.

SECTION 5. GENERAL SPECIFICATIONS AND MAINTENANCE

5.1 INTRODUCTION

This section of the manual provides additional necessary information to the operator for proper operation and maintenance of this machine.

The maintenance portion of this section is intended as information to assist the machine operator to perform daily maintenance tasks only, and does not replace the more thorough Preventive Maintenance and Inspection Schedule included in the Service and Maintenance Manual.

Other Publications Available Specific to this machine:

Illustrated Parts Manual - 8E	31210229
Illustrated Parts Manual - 10E	31210230
Hydraulic Schematic- 8E.....	FL0154
Hydraulic Schematic- 10E.....	FL0153
Electrical Schematic.....	ELE259

SECTION 5 – GENERAL SPECIFICATIONS AND MAINTENANCE

5.2 OPERATING SPECIFICATIONS

Table 5-1. Operating Specifications And Dimensions

Model	8E	8E-L	8EXL	10E	10E-L
Maximum Work Load	200 kg				
Maximum Persons	2	1	2	1	2
Maximum Manual Side Force	400 N	200 N	400 N	200 N	400 N
Maximum Operating Wind Speed	12.5 m/s	12.5 m/s	0	12.5 m/s	12.5 m/s
Maximum Elevated Travel Grade (Gradeability and Side slope)	4.4% (2.5°)				
Maximum Stowed Travel Grade (Gradeability) (Reference Fig. 3-15)	25% (14°)				
Maximum Stowed Travel Grade (Side slope) (Reference Fig. 3-15)	8.7% (5°)				
Maximum Drive Speed	Stowed	5.5 km/h			
	Mast Elevated	0.75 km/h			0.75 km/h ⁽¹⁾ or 0.40 km/h ⁽²⁾
Inside Turning Radius	0.55 m				
Outside Turning Radius	1.99 m				
Maximum Platform Height	6.20 m				8.10 m
Horizontal Reach	From centerline of machine	2.00 m		2.17 m	2.73 m
	From rear wheel edge	1.20 m		1.37 m	1.93 m
	From side wheel edge	1.50 m		1.67 m	2.23 m
Up and Over Clearance	5.08 m				6.51 m
Approximate Gross Machine Weight	2100 kg	1860 kg	2125 kg	2980 kg	2600 kg
Maximum Tire Load (per wheel)	1170 kg	1020 kg	1160 kg	1660 kg	1450 kg

SECTION 5 – GENERAL SPECIFICATIONS AND MAINTENANCE

Table 5-1. Operating Specifications And Dimensions

Model	8E	8E-L	8EXL	10E	10E-L
Maximum Hydraulic Pressure	16 MPa			18 MPa	
Maximum Ground Bearing Pressure	17.2 kg/cm ²	15.9 kg/cm ²	17.1 kg/cm ²	21.5 kg/cm ²	19.7 kg/cm ²
Electrical System Voltage	24 VDC				

(1) Up to 7.20 m (23.6') - Platform height with the jib fully raised.

(2) Above 7.20 m (23,6') - Platform height with the jib fully raised.

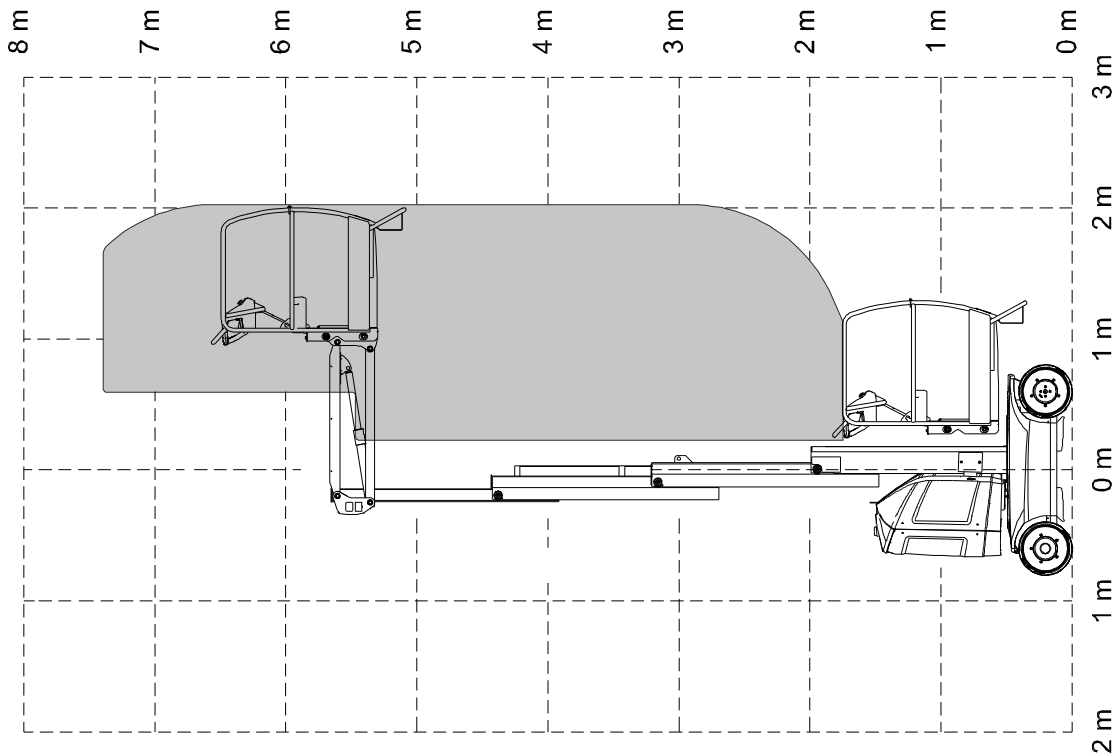

Figure 5-1. Range Diagram 8E & 8E-L

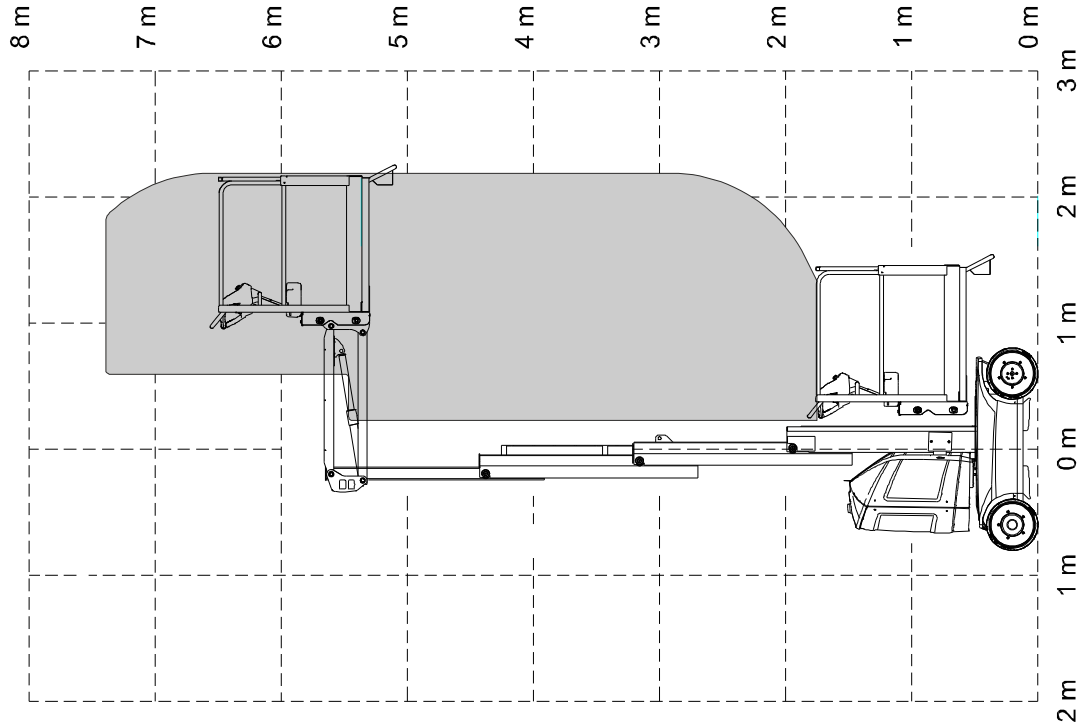

Figure 5-2. Range Diagram 8E XL

SECTION 5 – GENERAL SPECIFICATIONS AND MAINTENANCE

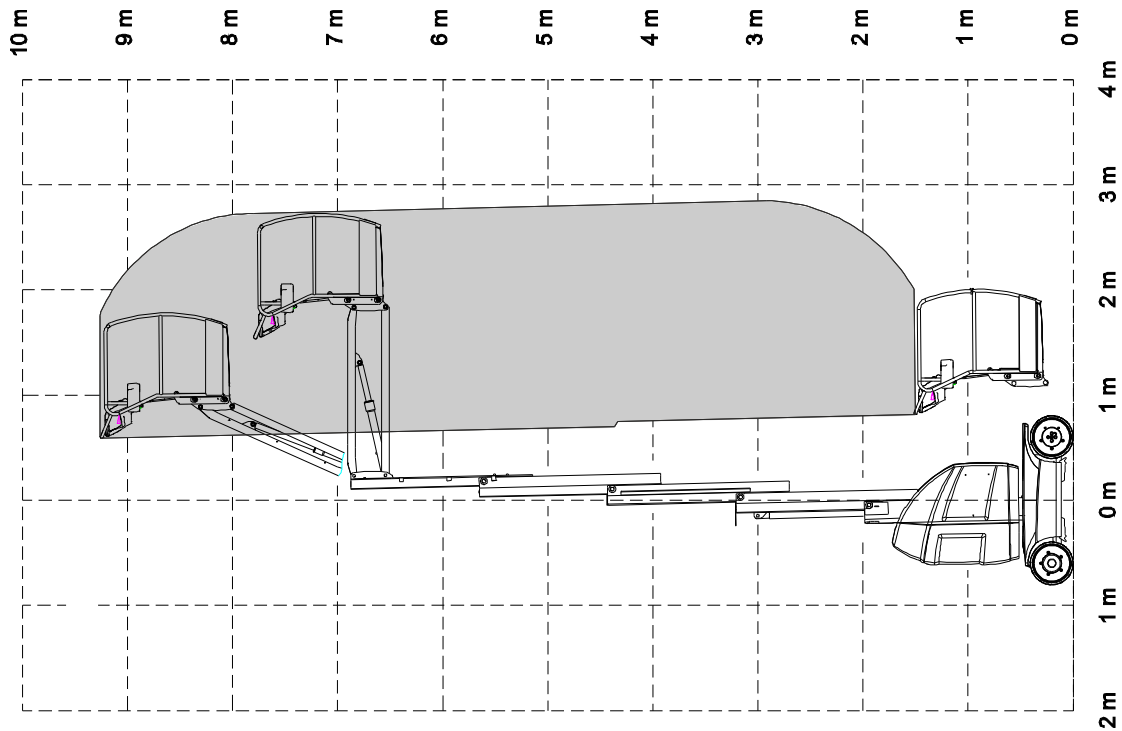

Figure 5-3. Range Diagram 10E & 10E-L

SECTION 5 – GENERAL SPECIFICATIONS AND MAINTENANCE

Table 5-2. Dimensions

DESCRIPTION	8E	8E-L	8E XL	10E	10E-L
Platform Height - Stowed	0.63 m			0.35 m	
Overall Stowed Machine Height	1.99 m				
Overall Machine Width	0.99 m				
Overall Machine Length	2.10 m		2.35 m	2.82 m	
Platform Size - Length	0.85 m		1.06 m	0.70 m	
Platform Size - Width	0.92 m		0.92 m	0.90 m	

Table 5-3. Tires Specifications

DESCRIPTION	All Models
Size	Ø406 x 125 mm
Wheel Bolts Torque	142-163 Nm

SECTION 5 – GENERAL SPECIFICATIONS AND MAINTENANCE

Table 5-4. Drive Motors - Hydraulic Power Unit

DESCRIPTION			All Models
Drive Motor	Voltage		15 VAC
	Power		0.85 kW
Hydraulic Power Unit	Motor	Voltage	24 VDC
		Power	3 kW
	Pump	Displacement	3.1 cc/rev - (0.19 cu.in/rev)
		Flow Rate	9.6 l/mn @ 13 MPa - (2.54 gal/min @ 1900 psi)
	Capacity	Tank	6 l (5.5 l usable) - (1.59 gal (1.46 gal usable))
		Hydraulic System (1)	Approx. 9 l - (2.38 gal)

(1) - Including Tank

SECTION 5 – GENERAL SPECIFICATIONS AND MAINTENANCE

Table 5-5. Battery Specifications

DESCRIPTION	8E	10E
Voltage (24 VDC)	4 batteries of 6V	
Amp Hour	213 Amp Hour @ 20 HR. Rate	260 Amp Hour @ 20 HR. Rate
Battery Weight (Approx.)	116 kg	142 kg

Table 5-6. Lubrication Specifications

KEY	SPECIFICATIONS	e.g.
A	Extreme Pressure - Multi Purpose Grease	MOBILUX EP2 COMPLEX EP2
B	Open Gear Lube	MOBILTAC 81
C	Non Detergent Mineral Oil (*)	MOBIL DTE 10XL 68
D	Synthetic Chain Oil	Fuchs VT 800

(*) To be adapted to the machine's operating conditions. See Table 5-11

NOTE: *Aside from JLG recommendations, it is not advisable to mix oils of different brands or types, as they may not contain the same required additives or be of comparable viscosities.*

Table 5-7. Hydraulic Oil Specifications - Standard

SPECIFICATION	NERVOFLUID VG 15	MOBIL DTE 10 XL15
ISO Viscosity grade	15	15
Cinematic Viscosity @ +40°C (104°F)	14.9 mm ² /s (cSt)	15.8 mm ² /s (cSt)
Cinematic Viscosity @ +100°C (212°F)	3.8 mm ² /s (cSt)	4.07 mm ² /s (cSt)
Pour Point, Max.	-40°C (-40°F)	-54°C (-65°F)
Flash Point, Min.	175°C (347°F)	182°C (359°F)
Viscosity Index	153	168
ISO 6743-4 Classification	HV	-

SECTION 5 – GENERAL SPECIFICATIONS AND MAINTENANCE

Table 5-8. Hydraulic Oil Specifications - Optional

SPECIFICATIONS	PANOLIN HLP SYNTH 3504	NERVOL EQUIVIS XV32	NERVOL AGROFLUID 32
Oil Type	Synthetic Biodegradable	Low Temperature	Synthetic Food Compatible
ISO Viscosity Grade	32 cSt	32 cSt	32 cSt
Cinematic Viscosity @ -20°C (-4°F)	1150 cSt	428 cSt	795 cSt
Cinematic Viscosity @ 0°C (32°F)	280 cSt	127 cSt	198 cSt
Cinematic Viscosity @ +40°C (104°F)	30.6 cSt	32.3 cSt	31 cSt
Pour Point, Max.	-58°C (-72.4°F)	-39°C (-38.2°F)	-60°C (-76°F)
Flash Point, Min.	240°C (464°F)	208°C (406.4°F)	230°C (446°F)
Viscosity Index	140	-	143
ISO 6743-4 Classification	-	HV	-

5.3 OPERATOR MAINTENANCE

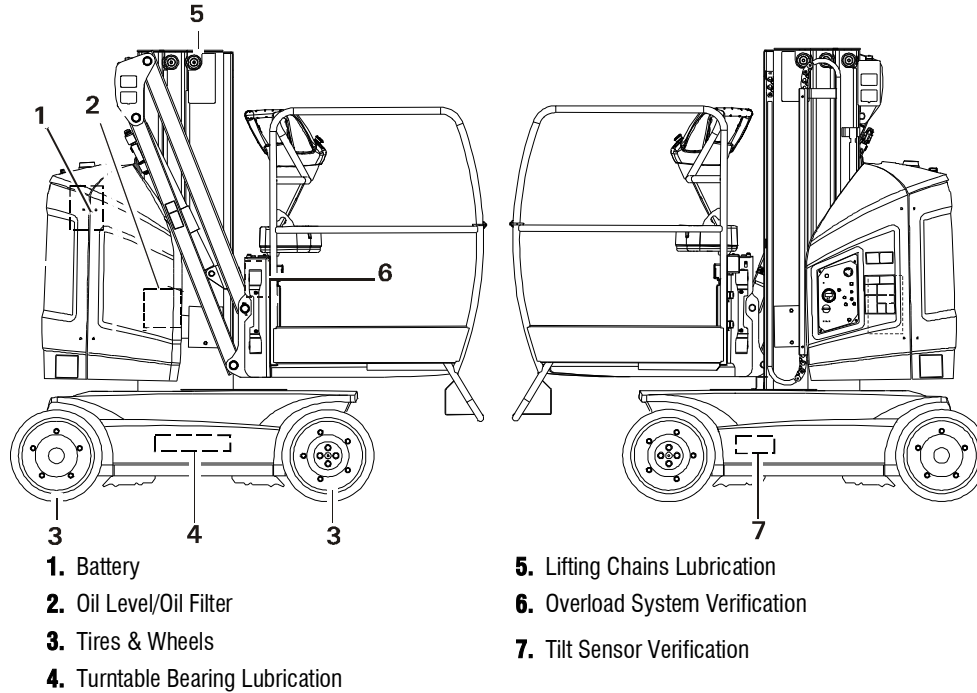
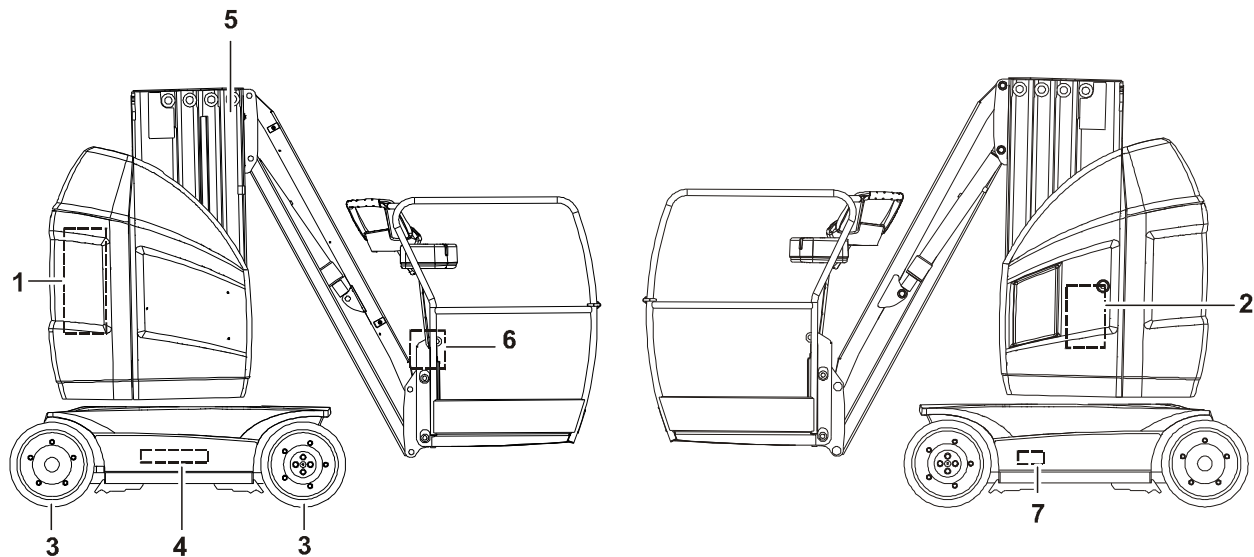

Figure 5-4. Operator Maintenance & Lubrication Diagram - 8E

SECTION 5 – GENERAL SPECIFICATIONS AND MAINTENANCE



1. Battery
2. Oil Level/Oil Filter
3. Tires & Wheels
4. Turntable Bearing Lubrication

5. Lifting Chains Lubrication
6. Overload System Verification
7. Tilt Sensor Verification

Figure 5-5. Operator Maintenance & Lubrication Diagram - 10E

5.4 CHASSIS HOOD REMOVAL

- Unscrew the four (4) retaining screws (a);
- Remove first the left chassis cover (b): Slide the cover to the rear of the machine (1) by approx. 20 mm (1”), then lift the covers (2) to remove it completely;
- Remove the right chassis cover (c): Proceed as for the left cover.

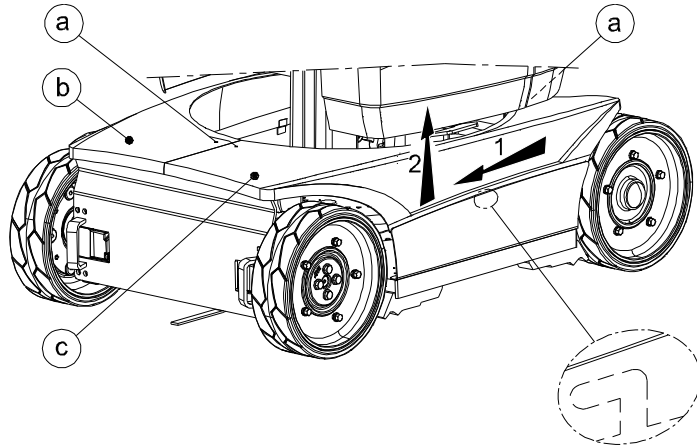

Figure 5-6. Chassis Hood Removal

5.5 BATTERY MAINTENANCE

Battery Maintenance and Safety Practices

⚠ CAUTION

ENSURE THAT BATTERY ACID DOES NOT COMES INTO CONTACT WITH SKIN OR CLOTHING. WEAR PROTECTIVE CLOTHING AND EYEWEAR WHEN WORKING WITH BATTERIES. NEUTRALIZE ANY BATTERY ACID SPILLS WITH BAKING SODA AND WATER. BATTERY ACID RELEASES AN EXPLOSIVE GAS WHILE CHARGING, ALLOW NO OPEN FAMES, SPARKS OR LIGHTED TOBACCO PRODUCTS IN THE AREA WHILE CHARGING BATTERIES. CHARGE BATTERIES ONLY IN A WELL VENTILATED AREA.

Regularly:

- Clean and dry the battery top.
- Ensure the connections are clean and tight.

Battery Voltage

NOTE: Voltage measures must be done after a complete charge, once the charger has been unplugged and after the battery has been standing for at least 15 minutes.

- Measure the cell voltage from B+ (Red Cable) to B- (Blue cable) and record the value in the battery service log.

NOTE: If important disparities are noticed between voltage of different cells contact JLG Product Support.

Use of a Battery in a Cold Environment

Low temperatures decrease battery capacity. The battery must be fully charged when the machine is operated in a cold environment.

Battery Not Working Continuously or Inactive Battery

A battery that is not used or used intermittently must be stored charged in a dry area away from freezing temperatures. A charge must be performed once a month.

- Disconnect the battery to insulate it electrically.
- Keep the top of the battery clean and dry to prevent self-discharge.

NOTICE

IF THE BATTERY IS NOT USED CONTINUOUSLY, IT MUST BE RECHARGED BEFORE USE AND AT LEAST ONCE A MONTH.

BEFORE RETURNING TO SERVICE A BATTERY THAT REMAIN INACTIVE FOR A LONG PERIOD OF TIME, CHARGE THE BATTERY AND CHECK VOLTAGE OF EACH CELL.

Battery Troubleshooting

Symptoms	Probable causes	Solutions
Low voltage in the cells in open circuit.	Short-circuit.	Clean battery top.
Battery temperature too high (over 45°).	Problem with the charger.	Get the charger checked by a technician.
	Bad air circulation during charge.	Open access doors to batteries during charge. Reduce temperature of the area where the battery is charged (artificial ventilation).
Battery incapable of supporting regular operation.	Battery shorted.	Change battery.
	Battery under charged.	Perform an equalization charge.
	Faulty cable or connection.	Check wire condition and connection.
	Battery at the end of its service life.	Replace the battery.

SECTION 5 – GENERAL SPECIFICATIONS AND MAINTENANCE

5.6 OIL LEVEL/OIL FILTER - 8E

NOTE: Care should be taken not to introduce any impurities (dirt, water etc.) while cap or plug is removed.

Hydraulic Oil Check

Lube Point - Hydraulic Tank

Reservoir Capacity: 6 liters

Lube - Hydraulic Oil (See Table 5-7)

Interval - Check Daily

NOTE: Check oil level with the wheels fully steered to the left.

1. Locate the **decals (1)** on the **tank (2)** through the left mast hood (a hole is intended to this purpose).
2. The oil level in the tank must be within the MIN (minimum) and Max (maximum) **markings (3)** of the decal.
3. If additional oil is required :
 - remove the left mast hood.
 - wipe all dirt and debris from the **filler/breather cap (4)** area, add proper grade of oil by using a funnel. Fill until oil level is between the MIN and MAX **markings (3)**.

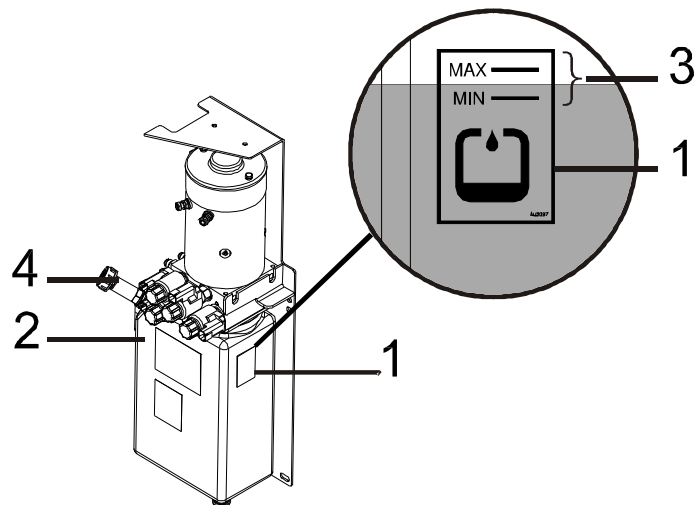

Figure 5-7. Hydraulic Oil Check - 8E

5.7 OIL LEVEL/OIL FILTER - 10E

NOTE: Care should be taken not to introduce any impurities (dirt, water etc.) while cap or plug is removed.

Hydraulic Oil Check

Lube Point - Hydraulic Tank

Reservoir Capacity: 6 liters

Lube - Hydraulic Oil (See Table 5-7)

Interval - Check Daily

NOTE: Check oil level with the wheels fully steered to the left.

1. Open the access door to the **hydraulic power unit (1)**.
2. Locate the **decal (2)** on the **tank (3)**.
3. The oil level in the tank must be within the MIN (minimum) and Max (maximum) **markings (4)** of the decal.
4. If additional oil is required, wipe all dirt and debris from the **filler/breather cap (5)** area, add proper grade of oil by using a funnel. Fill until oil level is between the MIN and MAX **markings (4)**.

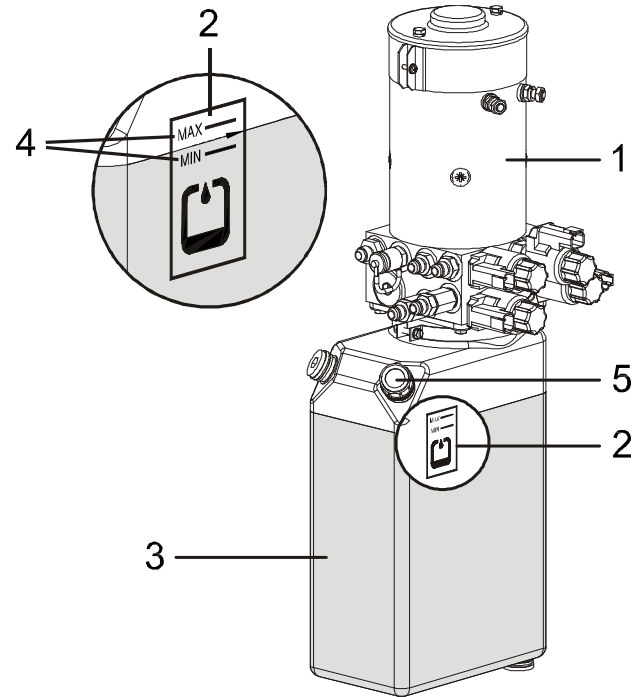

Figure 5-8. Hydraulic Oil Check - 10E

5.8 HYDRAULIC FILTER REPLACEMENT

Lube Point - Replaceable Element (JLG P/N: 930134)

Interval - After first 50 hours of operation and every 250 hours thereafter.

1. Turn machine power off at ground control station.
2. Remove the left mast hood (8E), open the access door (10E) to access to the **hydraulic power unit (1)**.
3. Wipe all dirt and debris from the **filter plug (2)** area.
4. Unscrew the **filter plug (2)**.
5. Install a screw (M6) in the **threaded hole (3)** of the filter and extract the **filter (4)**. Use a container to collect oil that can spill from the filter cavity.
6. Install a new filter (oil the filter O-ring before insertion) and the filter plug.
7. Perform a few swinging movements from the ground control station to bleed the air from the circuit.
8. Check oil level in the reservoir and adjust accordingly.

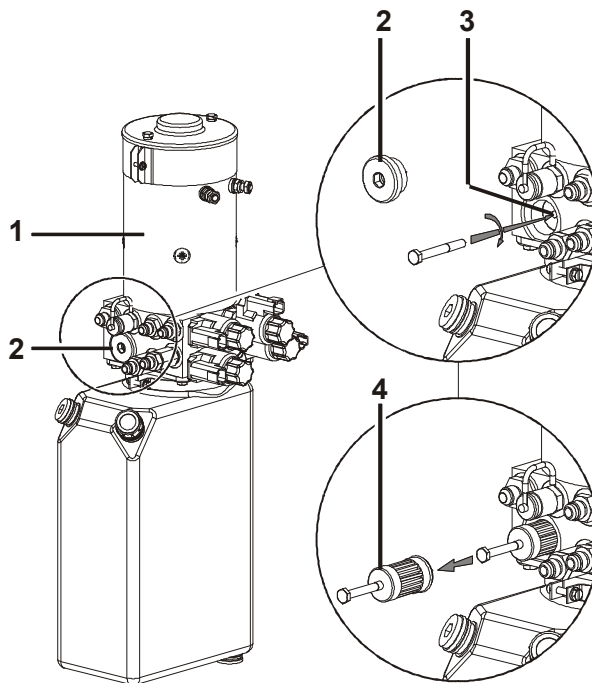

Figure 5-9. Hydraulic Filter Replacement

5.9 TIRES & WHEELS

Tire Wear and Damage

Inspect tires periodically for wear or damage. Tires with worn edges or distorted profiles require replacement. Tires with significant damage in the tread area or side wall, require immediate evaluation before replacing machine into service.

Wheel and Tire Replacement

Replacement wheels must have the same diameter and profile as the original. Replacement tires must be the same size and rating as the tire being replaced. Use of genuine parts is recommended.

Both tires/wheel on the same axle must be replaced:

- If the overall diameter of the tire is less than 400 mm.
- If any uneven wear is discovered.

A tire with significant damage in the tread area or sidewall requires immediate evaluation before placing the machine into service. If a cut, tear, chunk, or other discrepancy exceeds any one or more of the following dimensions, the tire must be replaced:

76 mm long, 19 mm wide, 19 mm deep

- If the metal wheel is visible at any point through the tread area of the tire.
- If more than one discrepancy exists in any quadrant of the wheel (within 90 degrees of one another).

Wheel Installation

It is extremely important to apply and maintain proper mounting torque.

⚠ WARNING

WHEEL LUG NUTS MUST BE INSTALLED AND MAINTAINED AT THE PROPER TORQUE TO PREVENT LOOSE WHEELS, BROKEN LUG NUTS, AND POSSIBLE SEPARATION OF WHEEL FROM THE AXLE. BE SURE TO USE ONLY THE LUG NUTS THAT MATCHED TO THE CONE ANGLE OF THE WHEEL.

Tighten the lug nuts to the proper torque to prevent wheels from coming loose. Use a torque wrench to tighten the fasteners. Over-tightening will result in breaking the lug nuts or permanently deforming the mounting holes in the wheels. The proper procedure for attaching wheels is as follow:

SECTION 5 – GENERAL SPECIFICATIONS AND MAINTENANCE

1. Start all lug nuts by hand to prevent cross threading. DO NOT use a lubricant on threads or nuts.
2. Tighten lug nuts in the following sequence.
3. The tightening of the lug nuts should be done in stages. Following the recommended sequence, tighten lug nut per wheel torque.

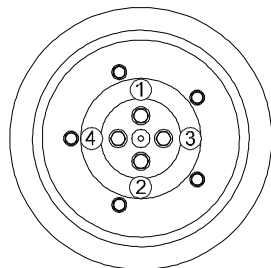
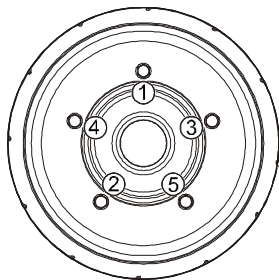

Table 5-9. Wheel Torque Chart

Torque Sequence - Front and Rear Wheels		
1 st Stage	2 nd Stage	3 rd Stage
28-42 N.m (20-30 ft.lbs)	91-112 N.m (65-80 ft.lbs)	142-163 N.m (105-120 ft.lbs)

Torque Sequence - Rear Hub		
1 st Stage	2 nd Stage	3 rd Stage
25-35 N.m (18-25 ft.lbs)	70-84 N.m (51-62 ft.lbs)	120-140 N.m (88-103 ft.lbs)

4. Wheel lug nuts should be torqued after the first 50 hours of operation and after each wheel removal. Check torque every 3 month or 125 hours of operation.

5.10 DECAL INSTALLATION

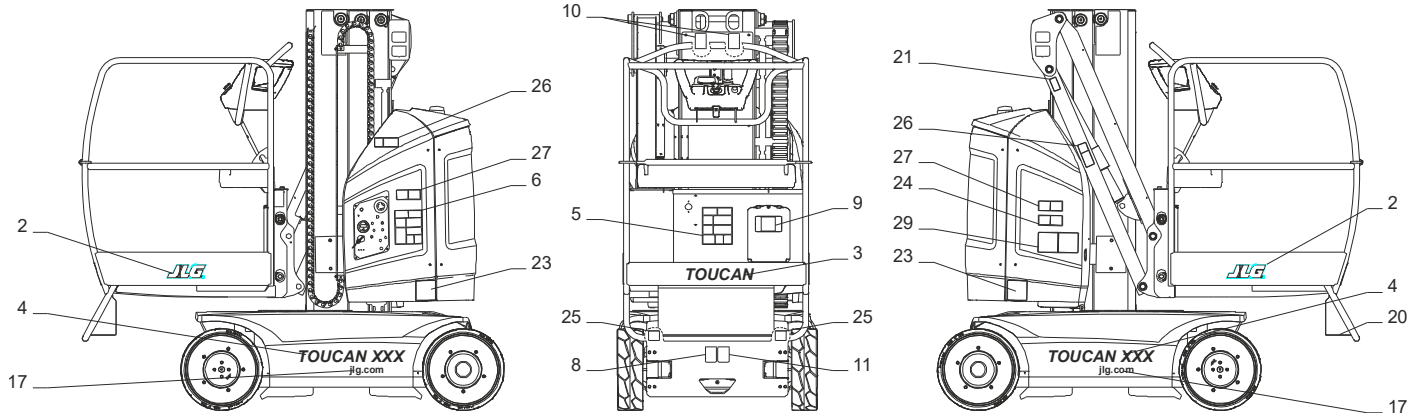

Figure 5-10. Decal Installation - 8E Sheet 1

SECTION 5 – GENERAL SPECIFICATIONS AND MAINTENANCE

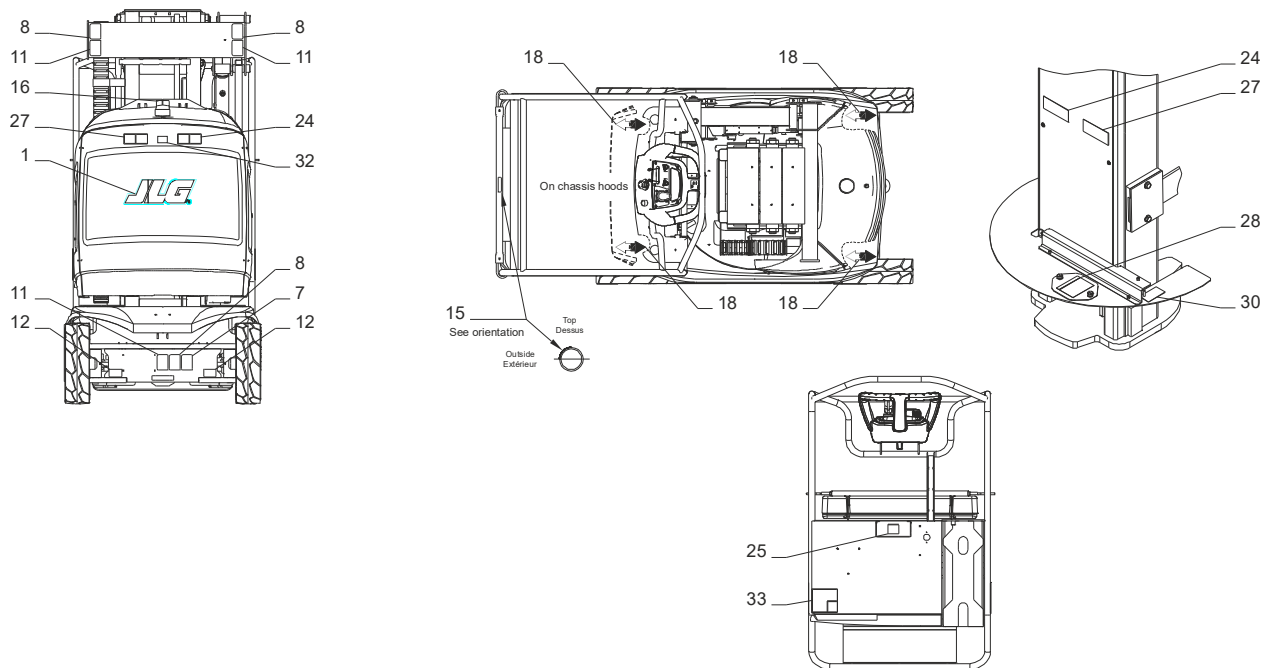

Figure 5-11. Decal Installation - 8E Sheet 2

SECTION 5 – GENERAL SPECIFICATIONS AND MAINTENANCE

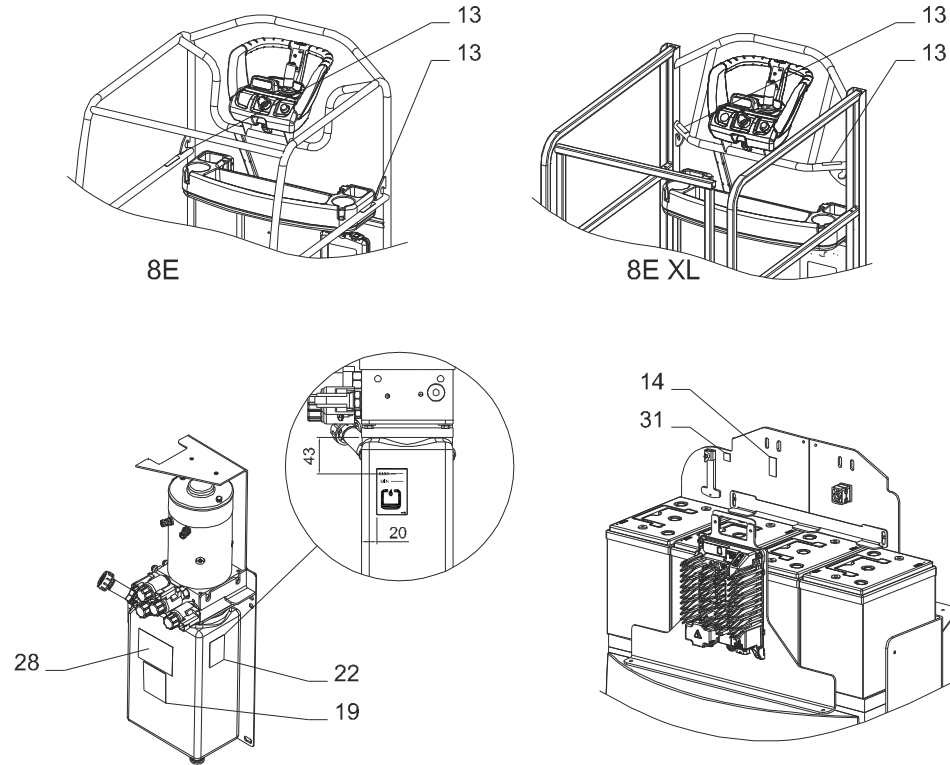

Figure 5-12. Decal Installation - 8E Sheet 3

SECTION 5 – GENERAL SPECIFICATIONS AND MAINTENANCE

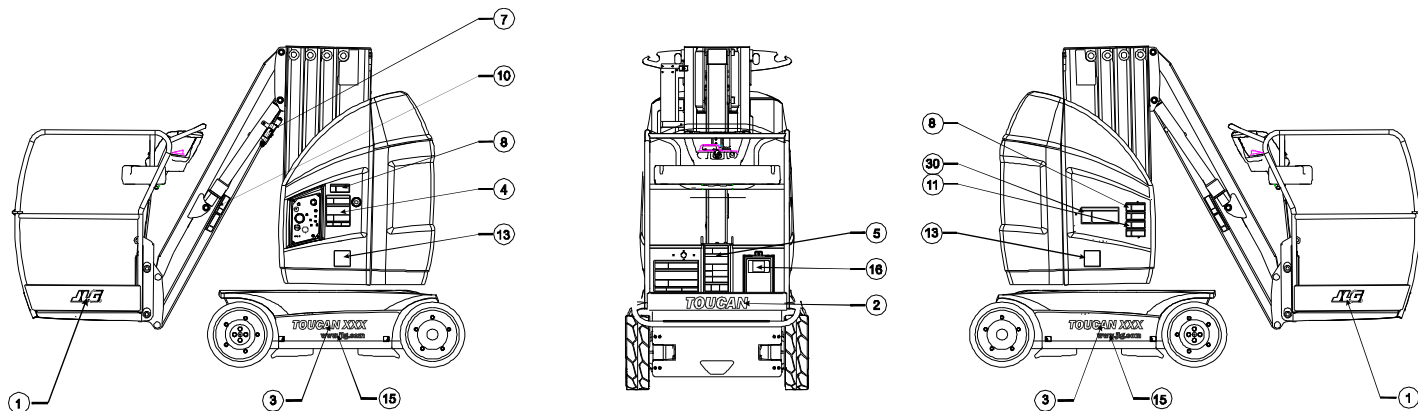

Figure 5-13. Decal Installation - 10E Sheet 1

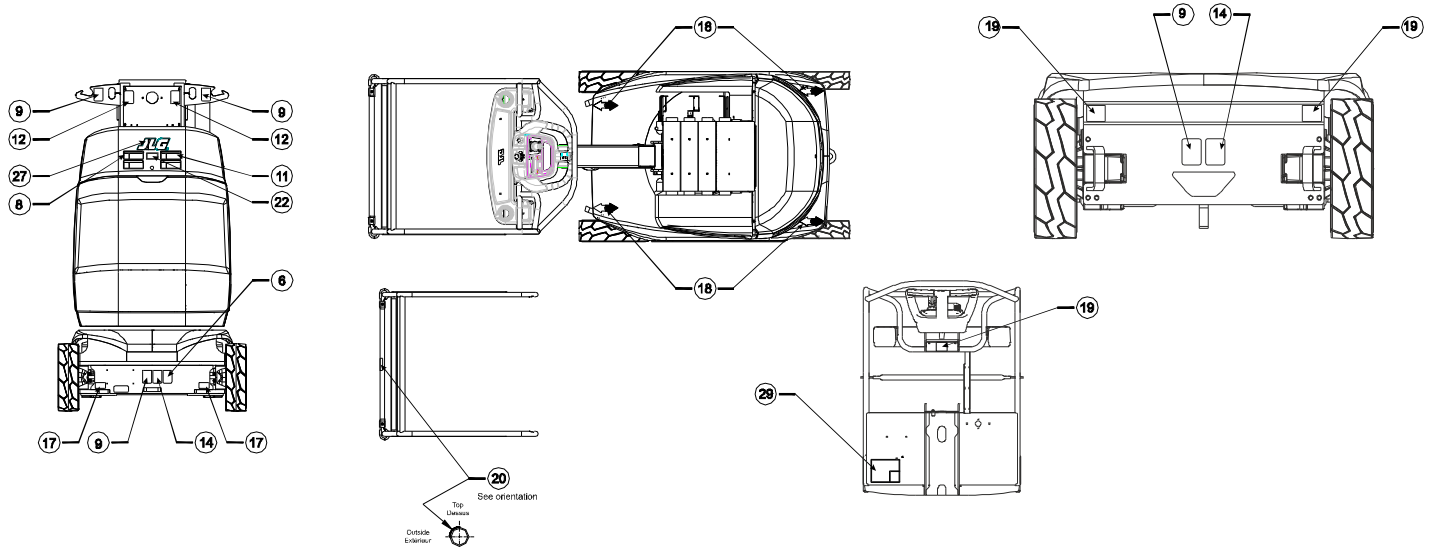
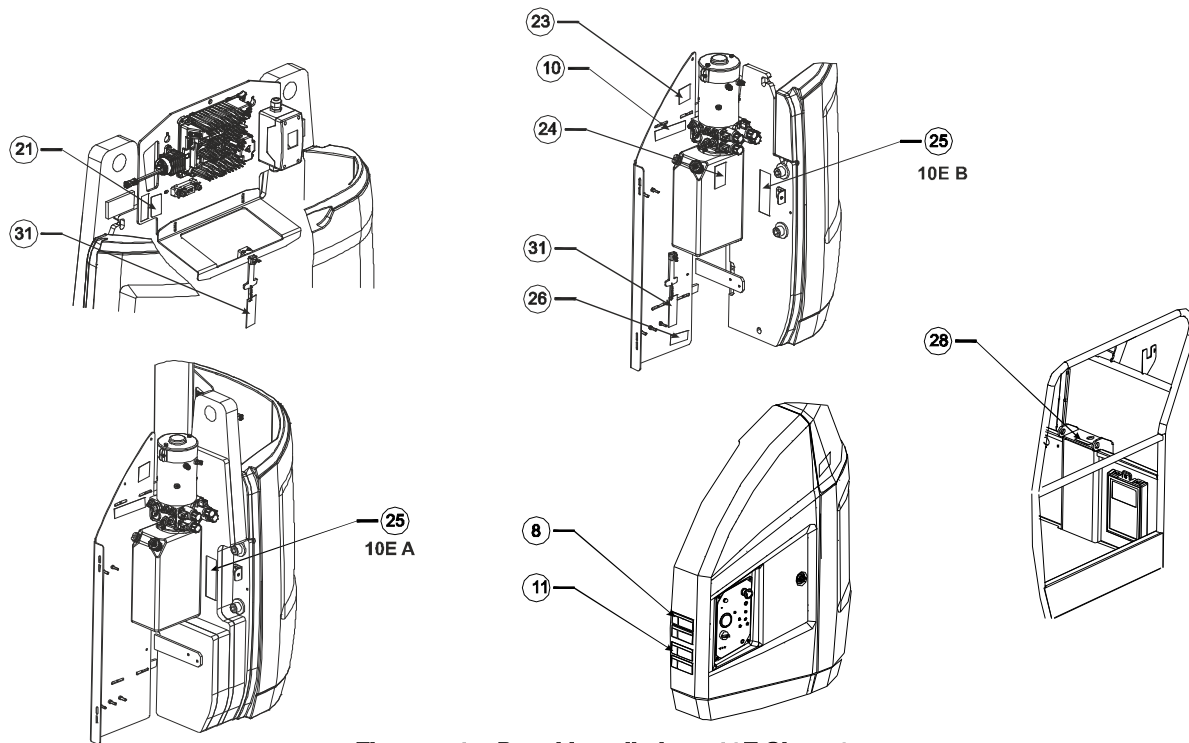

Figure 5-14. Decal Installation - 10E Sheet 2

SECTION 5 – GENERAL SPECIFICATIONS AND MAINTENANCE



SECTION 5 – GENERAL SPECIFICATIONS AND MAINTENANCE

Table 5-10. Machine Decal Installation Chart

Item #	8E	8E-L	8E XL	10E	10E-L	Item #	8E	8E-L	8E XL	10E	10E-L
1	1702773	1702773	1702773	1705781	1705781	18	AU0149	AU0149	AU0149	AU0149	AU0149
2	1705781	1705781	1705781	AU1825	AU1825	19	AU1423	AU1423	AU1423	AU2105	AU2105
3	AU1825	AU1825	AU1825	AU2100	1001214085	20	AU2062	AU2062	AU2062	1706493	1706493
4	1001214289	AU2130	1001214290	AU2109	1001214285	21	AU2095	AU2095	AU2095	1705803	1705803
5	AU2102	1001214284	1001214284	AU2102	1001214284	22	AU2097	AU2097	AU2097	AU2229	AU2229
6	AU2109	1001214285	1001214285	1001214286	1001214287	23	AU2098	AU2098	AU2098	AU1423	AU1423
7	1001214313	1001214314	1001214313	AU2095	AU2095	24	AU2103	AU2103	AU2103	AU2097	AU2097
8	1701499	1701499	1701499	AU2108	AU2108	25	AU2105	AU2105	AU2105	AU2099	AU2099
9	1701640	1701640	1701640	1703814	1703814	26	AU2107	AU2107	AU2107	1001219817	1001219817
10	1703811	1703811	1703811	AU2107	AU2107	27	AU2108	AU2108	AU2108	1706740	1706740
11	1703814	1703814	1703814	AU2103	AU2103	28	AU2134	AU2134	AU2134	1704277	1704277
12	1704016	1704016	1704016	1703811	1703811	29	AU2210	AU2210	AU2210	1001214288	1001214288
13	1704277	1704277	1704277	AU2098	AU2098	30	AU2212	AU2212	AU2212	1001217094	1001217094
14	1705803	1705803	1705803	1701499	1701499	31	AU2215	AU2215	AU2215	AU2215	AU2215
15	1706493	1706493	1706493	1706764	1706764	32	AU2229	AU2229	AU2229	-	-
16	1706740	1706740	1706740	1701640	1701640	33	1001213900	1001213900	1001213900	-	-
17	1706764	1706764	1706764	1704016	1704016	34	-	-	-	-	-

5.11 LUBRICATION

NOTE: *Recommended lubricating intervals are based on machine operation under normal conditions. For machines used in multi-shift operations and/or exposed to hostile environments or conditions, lubrication frequencies must be increased accordingly.*

Swing Bearing Race

Lube Points - 2 grease fittings

Capacity: A/R

Lube - A (See Table 5-6)

Interval - Every 250 hours of operation

1. Remove chassis hoods.
2. From ground control station, raise the mast to gain access to the turntable plate.
3. Locate the **access hole (1)** on the turntable plate.
4. Swing the structure to the right to gain access to the first **grease fitting (2)**.
5. Lubricate using a grease gun.
6. Swing the structure 180° to the left to gain access to the second grease fitting and lubricate.

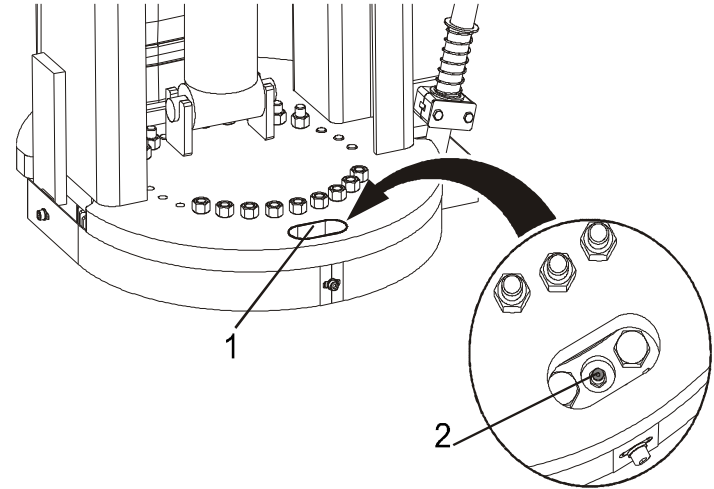

Figure 5-16. Swing Bearing Race Lubrication

Swing Bearing Teeth

Lube Points - Coat each tooth

Capacity: A/R

Lube - B (See Table 5-6)

Interval - Every 1000 hours of operation

1. Remove chassis hoods.
2. From ground control station, raise the mast to gain access to the turntable plate.
3. Remove **bearing teeth covers (1)**.
4. Apply grease on teeth using a **brush (2)**.

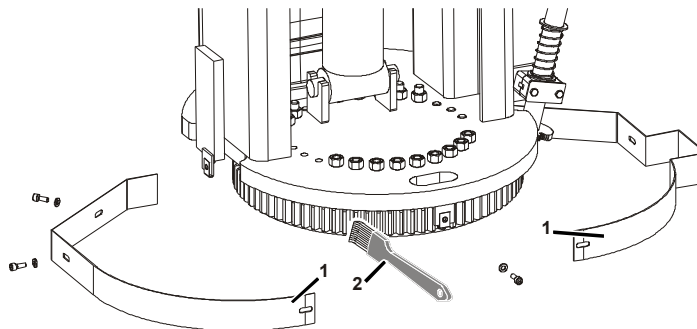

Figure 5-17. Swing Bearing Teeth Lubrication

Lifting Chains

Lube Points - 4 chains (8E), 6 chains (10E)

Capacity: A/R

Lube - C (See Table 5-6)

Interval - After the first 50 hours of operation and every 125 hours of operation (or every 30 days) thereafter.

Lubricant can be applied manually with a brush or by spraying. Apply lubricant longitudinally and transversally for the lubricant to reach the joints between the plates.

Table 5-11. Recommended Viscosity Grade

TEMPERATURE	ISO VISCOSITY GRADE
-15°C to 0°C (5° to 32°F)	15 to 32 mm ² /s (cSt)
0°C to 50°C (32°F to 122°F)	46 to 150 mm ² /s (cSt)

5.12 OVERLOAD SYSTEM VERIFICATION

Interval - At least every 6 months of operation.

1. Position the platform/ground select switch to the platform position.
2. Pull out both platform and ground emergency stop switches.
3. Place a 200 kg load evenly distributed on platform floor.
4. Lift the platform with your hands to apply a small upwards force (**F**), then remove the force to let the platform fall.
- No alarm should be triggered.

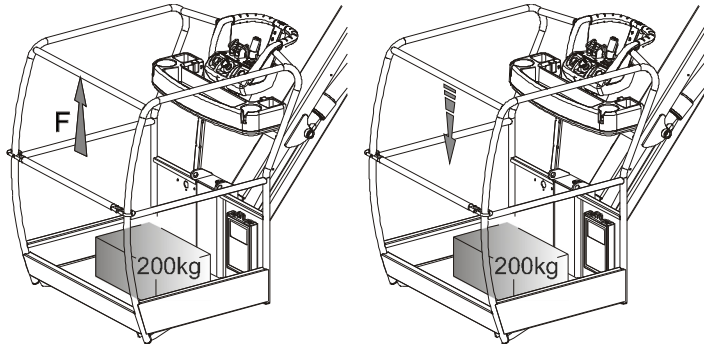

Figure 5-18. Overload System Verification

5. Add an additional weight of 15 kg to the 200 kg load.
6. Lift the platform with your hands to apply a small upwards force (**F**), then remove the force to let the platform fall.
- RED light indicators at both the ground and the platform control stations blink.
- An audible alarm sounds.
7. Remove the 15 kg additional load.
8. Lift the platform with your hands to apply a small upwards force (**F**), then remove the force to let the platform fall.
- No alarm should be triggered.

If the overload system does not activate as instructed, have a qualified technician calibrate and verify the system before placing the machine into service.

5.13 TILT SENSOR VERIFICATION

Interval - At least every 6 months of operation.

1. Drive the machine on a known level surface.
2. Chock both rear wheels.
3. Remove chassis hoods and place a level on the chassis positioned in line w/chassis.
4. Using a jack of appropriate capacity, lift the front on the chassis. The tilt alarm must be activated within 0.2° below the value in Table 5-1.
5. Place the spirit level perpendicular to the chassis and lift either the left or the right side of the chassis. The tilt alarm must be activated within 0.2° below the value in Table 5-1.
6. If the tilt warning is not activated within the indicated angle values, the tilt sensor must be recalibrated by a qualified technician before placing machine into service.

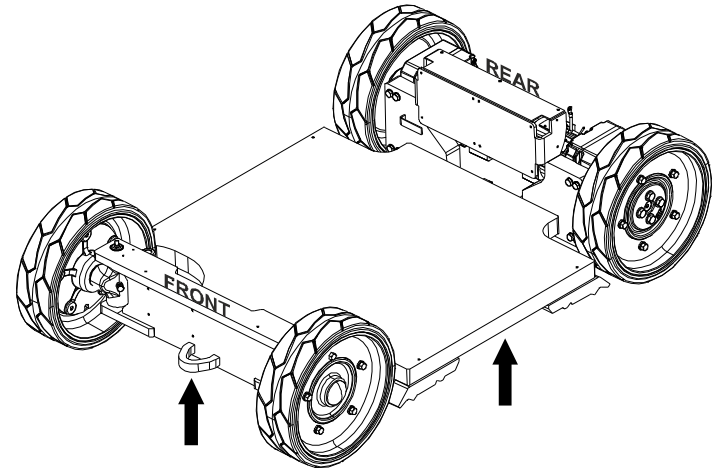

Figure 5-19. Jacking Points

SECTION 5 – GENERAL SPECIFICATIONS AND MAINTENANCE

5.14 SLACK CHAIN SENSORS CHECK

Interval - Check after every 6 months of operation.

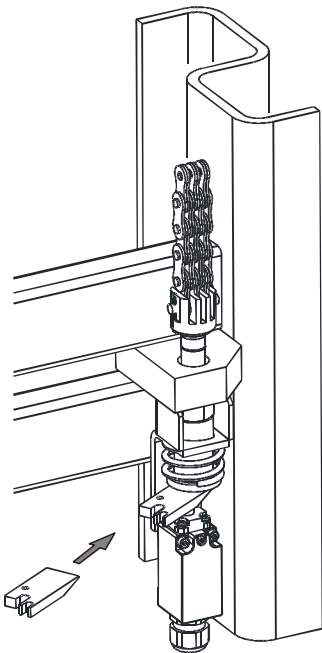

Figure 5-20. Slack/Broken Chain Sensors

Check the 2 (8E) or 3 (10E) slack chain sensors to ensure proper operation.

Location:

- 8E: one at the top of mast #1 and one at the bottom of mast #4.
- 10E: one at the top of mast #1, one at the top of mast #2 and one at the bottom of mast #5.

Wedge a block (P/N: ST2741) as illustrated opposite to activate the slack chain sensor and keep it activated. The system is functioning properly if:

1. From the Platform Control Console:
 - An acoustic alarm sounds.
 - The red slack chain indicator lights up on the Platform Control Panel.
 - All functions are disabled except boom and mast raising functions.
 - Prohibited movements are indicated by the orange light indicator on the platform control panel.
2. From the Ground Control Console:
 - An acoustic alarm sounds.

Repeat steps 1 to 2 for each slack chain sensor.

5.15 SUPPLEMENTAL INFORMATION

The following information is provided in accordance with the requirements of the European Machinery Directive 2006/42/EC and is only applicable to CE machines.

For electric powered machines, the equivalent continuous A-Weighted sound pressure level at the work platform is less than 70dB(A).

The vibration total value to which the hand-arm system is subjected does not exceed 2.5 m/s². The highest root mean square value of weighted acceleration to which the whole body is subjected does not exceed 0.5 m/s².

5.16 DIAGNOSTIC TROUBLE CODES (DTC)

Introduction

This sub-section provides a reference for Diagnostic Trouble Codes (DTC) read from the Multifunction Digital Indicator (MDI). For more information on the MDI, refer to Section 3. For information on the locations of any limit switches/sensors, refer to Section 2.

DTC's are sorted in groups by the first two digits, which is also the system distress lamp flash code. To troubleshoot multiple DTCs, start with the DTC with the higher first two digits. **If a correction is made during a check, conclude the check by cycling the machine power, using the emergency stop switch.**

5.17 DTC INDEX

DTC TABLE	PAGE
0-0 Help Comments	5-36
2-1 Power-Up	5-37
2-2 Platform Controls	5-38
2-3 Ground Controls	5-40
2-5 Function Prevented	5-42
3-1 Line Contactor Open Circuit	5-44
3-2 Line Contactor Short Circuit	5-44
3-3 Ground Output Driver	5-45
4-2 Thermal Limit	5-48
4-4 Battery Supply	5-50
4-6 Transmission and Drive System	5-52
6-6 Communication	5-53
6-7 Accessory	5-53
7-7 Electric Motor	5-54
8-1 Tilt Sensor	5-55
8-2 Platform Load Sense	5-56
8-6 Steering / Axle	5-56
8-7 Safety System Override	5-57
9-9 Hardware	5-58

5.18 DTC CHECK TABLES

 **0-0 Help Comments**

DTC	FAULT MESSAGE	DESCRIPTION	CHECK
001	EVERYTHING OK	The normal help message in Platform Mode. Displays on the analyzer only.	
002	GROUND MODE OK	The normal help message in Ground Mode. Displays on the analyzer only.	
008	FUNCTIONS LOCKED OUT - SYSTEM POWERED DOWN	After 2 hours without activity, the Control System enters a low-power state to preserve battery charge. Displays on the analyzer only; the MDI's LED is blinking with the display Off.	<ul style="list-style-type: none"> • Normal operation should resume after a power cycle. Refer problem to a qualified JLG mechanic.
0010	RUNNING AT CUTBACK - OUT OF TRANSPORT POSITION	Drive speed is limited while the mast is elevated. Displays on the analyzer only.	<ul style="list-style-type: none"> • Fully stow the platform. • Check that the mast switches are securely mounted. Refer problem to a qualified JLG mechanic.
0022	DIFFERENT FUNCTION SELECTED & IGNORED	Two hydraulically powered movements simultaneously controlled.	<ul style="list-style-type: none"> • Release joysticks and allow to center. Refer problem to a qualified JLG mechanic.
0023	FUNCTION SELECTED BUT TRIGGER SWITCH OPEN	One of the drive joystick functions was activated, but the trigger switch was not.	<ul style="list-style-type: none"> • Release joystick and allow to center. • Check if the joystick is obstructed or jammed. • Check if the trigger switch is damaged. Refer problem to a qualified JLG mechanic.

SECTION 5 – GENERAL SPECIFICATIONS AND MAINTENANCE

DTC	FAULT MESSAGE	DESCRIPTION	CHECK
0027	FUNCTION SELECTED BUT LIFT ENABLE SWITCH OPEN	The Mast or the Jib joystick was activated, but the enable switch was not.	<ul style="list-style-type: none"> • Release joystick and allow to center. • Check if the joystick is obstructed or jammed. • Check if the enable switch is damaged. Refer problem to a qualified JLG mechanic.
0028	DRIVE PREVENTED - TILTED & ELEVATED	Drive is prevented while the platform is not in transport position and the chassis is not level.	<ul style="list-style-type: none"> • Check that the machine is tilted. If so, lower the platform and reposition the machine to a level surface. • Fully stow the platform. • Check that the tilt sensor is securely mounted and its wire connected. Refer problem to a qualified JLG mechanic.
0029	RUNNING AT CREEP - MAX ELEVATION	Drive speed is limited while the mast is fully extended. Displays on the analyzer only.	<ul style="list-style-type: none"> • Fully stow the platform. • Check that the mast switches are securely mounted. Refer problem to a qualified JLG mechanic.

2-1 Power-Up

DTC	FAULT MESSAGE	DESCRIPTION	CHECK
211	POWER CYCLE	The normal help message is issued at each power cycle. Displays on the analyzer only.	Normal operation. No check necessary.
212	KEYSWITCH FAULTY	Both Platform and Ground Modes are selected simultaneously. Defaults to Ground Mode.	Refer problem to a qualified JLG mechanic.

SECTION 5 – GENERAL SPECIFICATIONS AND MAINTENANCE

2-2 Platform Controls

DTC	FAULT MESSAGE	DESCRIPTION	CHECK
221	FUNCTION PROBLEM - HORN PERMANENTLY SELECTED	The horn switch was closed during power-up in platform mode.	<ul style="list-style-type: none">• Check if the horn switch is damaged, obstructed or jammed. Refer problem to a qualified JLG mechanic.
224	FUNCTION PROBLEM - STEER LEFT PERMANENTLY SELECTED	The Steer Left Switch was closed during power-up in platform mode.	<ul style="list-style-type: none">• Check if the steer left switch is obstructed or jammed. Refer problem to a qualified JLG mechanic.
225	FUNCTION PROBLEM - STEER RIGHT PERMANENTLY SELECTED	The Steer Right Switch was closed during power-up in platform mode.	<ul style="list-style-type: none">• Check if the steer right switch is obstructed or jammed. Refer problem to a qualified JLG mechanic.
226	ACCELERATOR FAULTY - WIPER OUT OF RANGE	The joystick wiper signal input is outside the acceptable voltage range.	<ul style="list-style-type: none">• Center joystick and check to see if a power cycle will clear DTC. Refer problem to a qualified JLG mechanic.
227	STEER SWITCHES FAULTY	The steer left and steer right inputs were closed simultaneously.	<ul style="list-style-type: none">• Check if the steer switches are damaged, obstructed or jammed. Refer problem to a qualified JLG mechanic.
228	FUNCTION LOCKED OUT - ACCELERATOR NOT CENTERED	The joystick was not centered at power-up in platform mode.	<ul style="list-style-type: none">• Release joystick and allow to center.• Check if the joystick is obstructed or jammed. Refer problem to a qualified JLG mechanic.

SECTION 5 – GENERAL SPECIFICATIONS AND MAINTENANCE

DTC	FAULT MESSAGE	DESCRIPTION	CHECK
229	FUNCTION PROBLEM - TRIGGER PERMANENTLY CLOSED	The trigger switch was closed during power-up in platform mode.	<ul style="list-style-type: none"> • Check if the trigger switch is obstructed or jammed. Refer problem to a qualified JLG mechanic.
2210	TRIGGER CLOSED TOO LONG WHILE IN NEUTRAL	The trigger switch was closed for more than seven seconds while the joystick was centered.	<ul style="list-style-type: none"> • Check if the trigger switch is obstructed or jammed. Refer problem to a qualified JLG mechanic.
2233	FUNCTION ENABLE RELAY - INVALID SIGNAL	There is a problem with the Function Enable Relay.	Refer problem to a qualified JLG mechanic.
2240	LIFT ENABLE SWITCH PERMANENTLY SELECTED	The Lift Enable Switch was closed during power-up in platform mode.	<ul style="list-style-type: none"> • Check if the lift enable switch is obstructed or jammed. Refer problem to a qualified JLG mechanic.
2241	LIFT ENABLE SWITCH PERMANENTLY SELECTED	The Lift Enable Switch was closed during power-up in platform mode.	<ul style="list-style-type: none"> • Check if the lift enable switch is obstructed or jammed. Refer problem to a qualified JLG mechanic.
2242	FUNCTION LOCKED OUT - MAST JOYSTICK NOT CENTERED	The Mast Joystick was not centered at power-up in platform mode.	<ul style="list-style-type: none"> • Release joystick and allow to center. • Check if the joystick is obstructed or jammed. Refer problem to a qualified JLG mechanic.
2243	FUNCTION LOCKED OUT - JIB JOYSTICK NOT CENTERED	The Jib Joystick was not centered at power-up in platform mode.	<ul style="list-style-type: none"> • Release joystick and allow to center. • Check if the joystick is not obstructed or jammed. Refer problem to a qualified JLG mechanic.
2244	GATE LIMIT SWITCH - FAULTY	If equipped - A problem has been detected in this function.	<ul style="list-style-type: none"> • Check if the Gate Limit Switches are damaged, obstructed or jammed. Refer problem to a qualified JLG mechanic.

SECTION 5 – GENERAL SPECIFICATIONS AND MAINTENANCE

2-3 Ground Controls

DTC	FAULT MESSAGE	DESCRIPTION	CHECK
233	FUNCTION PROBLEM - BRAKE RELEASE PERMANENTLY SELECTED	The Brake Release Switch was closed during power-up in ground mode.	<ul style="list-style-type: none">• Check if the concerned switch is damaged, obstructed or jammed. Refer problem to a qualified JLG mechanic.
2310	FUNCTION PROBLEM - GROUND ENABLE PERMANENTLY SELECTED	The Ground Enable Switch was closed during power-up in ground mode.	<ul style="list-style-type: none">• Check if the concerned switch is damaged, obstructed or jammed. Refer problem to a qualified JLG mechanic.
2368	FUNCTION PROBLEM - MAST LIFT UP PERMANENTLY SELECTED	The Mast Lift Up Switch was closed during power-up in ground mode.	<ul style="list-style-type: none">• Check if the concerned switch is damaged, obstructed or jammed. Refer problem to a qualified JLG mechanic.
2369	FUNCTION PROBLEM - MAST LIFT DOWN PERMANENTLY SELECTED	The Mast Lift Down Switch was closed during power-up in ground mode.	<ul style="list-style-type: none">• Check if the concerned switch is damaged, obstructed or jammed. Refer problem to a qualified JLG mechanic.
2370	FUNCTION PROBLEM - JIB LIFT UP PERMANENTLY SELECTED	The Jib Lift Up Switch was closed during power-up in ground mode.	<ul style="list-style-type: none">• Check if the concerned switch is damaged, obstructed or jammed. Refer problem to a qualified JLG mechanic.
2371	FUNCTION PROBLEM - JIB LIFT DOWN PERMANENTLY SELECTED	The Jib Lift Down Switch was closed during power-up in ground mode.	<ul style="list-style-type: none">• Check if the concerned switch is damaged, obstructed or jammed. Refer problem to a qualified JLG mechanic.

SECTION 5 – GENERAL SPECIFICATIONS AND MAINTENANCE

DTC	FAULT MESSAGE	DESCRIPTION	CHECK
2372	FUNCTION PROBLEM - SWING LEFT PERMANENTLY SELECTED	The Swing Left Switch was closed during power-up in ground mode.	<ul style="list-style-type: none"> • Check if the concerned switch is damaged, obstructed or jammed. Refer problem to a qualified JLG mechanic.
2373	FUNCTION PROBLEM - SWING RIGHT PERMANENTLY SELECTED	The Swing Right Switch was closed during power-up in ground mode.	<ul style="list-style-type: none"> • Check if the concerned switch is damaged, obstructed or jammed. Refer problem to a qualified JLG mechanic.
2374	MAST SWITCH FAULTY	The Mast Lift Up and Down Switches are active simultaneously.	<ul style="list-style-type: none"> • Check if one of the concerned switches is damaged, obstructed or jammed. Refer problem to a qualified JLG mechanic.
2375	JIB SWITCH FAULTY	The Jib Lift Up and Down Switches are active simultaneously.	<ul style="list-style-type: none"> • Check if one of the concerned switches is damaged, obstructed or jammed. Refer problem to a qualified JLG mechanic.
2376	SWING SWITCH FAULTY	The Swing Right and Left Switches are active simultaneously.	<ul style="list-style-type: none"> • Check if one of the concerned switches is damaged, obstructed or jammed. Refer problem to a qualified JLG mechanic.
2377	CHAIN SLACK SWITCH DISAGREEMENT	A problem has been detected in this function.	Refer problem to a qualified JLG mechanic.
2378	MAIN MAST LIMIT SWITCH - DECOUPLED	The information from the Mast Limit Switches is not consistent.	<ul style="list-style-type: none"> • Check if one of the concerned limit switches is damaged, obstructed or jammed. Refer problem to a qualified JLG mechanic.

SECTION 5 – GENERAL SPECIFICATIONS AND MAINTENANCE

DTC	FAULT MESSAGE	DESCRIPTION	CHECK
2379	MAIN MAST LIMIT SWITCH - NOT RESPONDING	The status of the Main Mast Limit Switch does not change while raising the mast.	<ul style="list-style-type: none"> Check if the Main Mast limit switch (left switch) is damaged, obstructed or jammed. Refer problem to a qualified JLG mechanic.
2380	MAIN MAST LIMIT SWITCH - FAULTY	A problem has been detected in this function.	Refer problem to a qualified JLG mechanic.
2381	MAST LIMIT SWITCH 2 - FAULTY	A problem has been detected in this function.	Refer problem to a qualified JLG mechanic.
2382	FUNCTION PREVENTED - OVERSWING DETECTED	The structure is swung beyond the rear tires or further in either direction.	<ul style="list-style-type: none"> If the structure is in line with the chassis, check the Drive Orientation Switch (on the turntable) for damage. Refer problem to a qualified JLG mechanic.

2-5 Function Prevented

DTC	FAULT MESSAGE	DESCRIPTION	CHECK
259	MODEL CHANGED - HYDRAULICS SUSPENDED - CYCLE EMS	The model selection has been changed.	Refer problem to a qualified JLG mechanic.
2516	DRIVE PREVENTED - ABOVE ELEVATION	DRIVE CUTOUT set to 1 (YES), and the mast is elevated.	<ul style="list-style-type: none"> Fully stow the platform. Refer problem to a qualified JLG mechanic.

SECTION 5 – GENERAL SPECIFICATIONS AND MAINTENANCE

DTC	FAULT MESSAGE	DESCRIPTION	CHECK
2538	FUNCTION PREVENTED - CHARGER CONNECTED	Functions are prevented while the vehicle is charging.	<ul style="list-style-type: none"> • Check if the charger is connected to off board power source and disconnect if desired. Refer problem to a qualified JLG mechanic.
2542	FUNCTION PREVENTED - BRAKES ELECTRONICALLY RELEASED FOR TOWING	Manual brake release mode is activated. Drive or lift is not possible.	<ul style="list-style-type: none"> • Push manual brake release switch again or cycle power to clear manual brake release mode. • Check if the brake release switch is damaged, obstructed or jammed. Refer problem to a qualified JLG mechanic.
2543	FUNCTION PREVENTED - CHAIN SLACK DETECTED	Slack was detected in the mast chain.	<ul style="list-style-type: none"> • Refer to section 4 for the required operations to clear the fault. • Check if the Chain Slack Limit Switches are damaged, obstructed or jammed. Refer problem to a qualified JLG mechanic.
2544	ALL FUNCTIONS PREVENTED - FAULTY MASTER VALVE ENABLE	A problem has been detected in this function.	Refer problem to a qualified JLG mechanic.
2545	ALL FUNCTIONS PREVENTED - FAULTY SLAVE VALVE ENABLE	A problem has been detected in this function.	Refer problem to a qualified JLG mechanic.
2548	SYSTEM TEST MODE ACTIVE	The system is in test mode.	<ul style="list-style-type: none"> • Cycle power to clear test mode. Refer problem to a qualified JLG mechanic.

SECTION 5 – GENERAL SPECIFICATIONS AND MAINTENANCE

3-1 Line Contactor Open Circuit

DTC	FAULT MESSAGE	DESCRIPTION	CHECK
311	OPEN CIRCUIT LINE CONTACTOR	There is a problem with the line contactor.	Refer problem to a qualified JLG mechanic.
312	CONTACTOR DRIVER PERMANENTLY OFF	There is a problem with the power module line contactor control.	Refer problem to a qualified JLG mechanic.

3-2 Line Contactor Short Circuit

DTC	FAULT MESSAGE	DESCRIPTION	CHECK
321	LINE CONTACTOR MISWIRED ON OR WELDED	There is a problem with the line contactor.	Refer problem to a qualified JLG mechanic.
322	CONTACTOR DRIVER PERMANENTLY ON	There is a problem with the power module line contactor control	Refer problem to a qualified JLG mechanic.
324	VALVE ENABLE DRIVER PERMANENTLY ON	A problem has been detected in this function.	Refer problem to a qualified JLG mechanic.

 3-3 Ground Output Driver

DTC	FAULT MESSAGE	DESCRIPTION	CHECK
3312	LEFT BRAKE - SHORT TO BATTERY	A problem has been detected in this function.	Refer problem to a qualified JLG mechanic.
3313	RIGHT BRAKE - SHORT TO BATTERY	A problem has been detected in this function.	Refer problem to a qualified JLG mechanic.
3314	LEFT BRAKE - OPEN CIRCUIT	A problem has been detected in this function.	Refer problem to a qualified JLG mechanic.
3315	RIGHT BRAKE - OPEN CIRCUIT	A problem has been detected in this function.	Refer problem to a qualified JLG mechanic.
33100	JIB LIFT UP VALVE - SHORT TO GROUND	A problem has been detected in this function.	Refer problem to a qualified JLG mechanic.
33101	JIB LIFT UP VALVE - OPEN CIRCUIT	A problem has been detected in this function.	Refer problem to a qualified JLG mechanic.
33102	JIB LIFT UP VALVE - SHORT TO BATTERY	A problem has been detected in this function.	Refer problem to a qualified JLG mechanic.
33103	JIB LIFT DOWN VALVE - SHORT TO GROUND	A problem has been detected in this function.	Refer problem to a qualified JLG mechanic.
33104	JIB LIFT DOWN VALVE - OPEN CIRCUIT	A problem has been detected in this function.	Refer problem to a qualified JLG mechanic.

SECTION 5 – GENERAL SPECIFICATIONS AND MAINTENANCE

DTC	FAULT MESSAGE	DESCRIPTION	CHECK
33105	JIB LIFT DOWN VALVE - SHORT TO BATTERY	A problem has been detected in this function.	Refer problem to a qualified JLG mechanic.
33297	LEFT BRAKE - SHORT TO GROUND	A problem has been detected in this function.	Refer problem to a qualified JLG mechanic.
33304	RIGHT BRAKE - SHORT TO GROUND	A problem has been detected in this function.	Refer problem to a qualified JLG mechanic.
33355	STEER VALVE - SHORT TO GROUND	A problem has been detected in this function.	Refer problem to a qualified JLG mechanic.
33356	STEER VALVE - OPEN CIRCUIT	A problem has been detected in this function.	Refer problem to a qualified JLG mechanic.
33358	FLOW DIRECTION VALVE - SHORT TO GROUND	A problem has been detected in this function.	Refer problem to a qualified JLG mechanic.
33359	FLOW DIRECTION VALVE - OPEN CIRCUIT	A problem has been detected in this function.	Refer problem to a qualified JLG mechanic.
33362	SWING VALVE - OPEN CIRCUIT	A problem has been detected in this function.	Refer problem to a qualified JLG mechanic.
33365	MAST VALVE - OPEN CIRCUIT	A problem has been detected in this function.	Refer problem to a qualified JLG mechanic.
33366	PROPORTIONAL RELIEF VALVE - SHORT TO BATTERY	A problem has been detected in this function.	Refer problem to a qualified JLG mechanic.

SECTION 5 – GENERAL SPECIFICATIONS AND MAINTENANCE

DTC	FAULT MESSAGE	DESCRIPTION	CHECK
33367	PROPORTIONAL RELIEF VALVE - SHORT TO GROUND	A problem has been detected in this function.	Refer problem to a qualified JLG mechanic.
33368	PROPORTIONAL RELIEF VALVE - OPEN CIRCUIT	A problem has been detected in this function.	Refer problem to a qualified JLG mechanic.
33376	MASTER MODULE OUTPUTS - SHORT TO GROUND	A problem has been detected in this function.	Refer problem to a qualified JLG mechanic.
33380	OVERLOAD LIGHTS - SHORT TO BATTERY	A problem has been detected in this function.	Refer problem to a qualified JLG mechanic.
33381	MASTER MODULE OUTPUTS - SHORT TO BATTERY	A problem has been detected in this function.	Refer problem to a qualified JLG mechanic.
33382	SLAVE MODULE OUTPUTS - SHORT TO BATTERY	A problem has been detected in this function.	Refer problem to a qualified JLG mechanic.
33383	BEACON LIGHT - OPEN CIRCUIT	A problem has been detected in this function.	Refer problem to a qualified JLG mechanic.
33384	BEACON LIGHT - SHORT TO GROUND	A problem has been detected in this function.	Refer problem to a qualified JLG mechanic.
33386	SLAVE MODULE OUTPUTS - SHORT TO GROUND	A problem has been detected in this function.	Refer problem to a qualified JLG mechanic.

SECTION 5 – GENERAL SPECIFICATIONS AND MAINTENANCE

DTC	FAULT MESSAGE	DESCRIPTION	CHECK
33387	OVERLOAD LIGHT - SHORT TO GROUND	A problem has been detected in this function.	Refer problem to a qualified JLG mechanic.
33388	OVERLOAD LIGHT - OPEN CIRCUIT	A problem has been detected in this function.	Refer problem to a qualified JLG mechanic.
33389	RIGHT BRAKE RETURN - SHORT TO GROUND	A problem has been detected in this function.	Refer problem to a qualified JLG mechanic.
33390	LEFT BRAKE RETURN - SHORT TO GROUND	A problem has been detected in this function.	Refer problem to a qualified JLG mechanic.
33391	RIGHT BRAKE RETURN - SHORT TO BATTERY	A problem has been detected in this function.	Refer problem to a qualified JLG mechanic.
33392	LEFT BRAKE RETURN - SHORT TO BATTERY	A problem has been detected in this function.	Refer problem to a qualified JLG mechanic.

4-2 Thermal Limit

DTC	FAULT MESSAGE	DESCRIPTION	CHECK
426	MASTER MODULE TEMPERATURE - OUT OF RANGE	The Master Module (right controller) temperature sensor is out of the permitted range.	Refer problem to a qualified JLG mechanic.

SECTION 5 – GENERAL SPECIFICATIONS AND MAINTENANCE

DTC	FAULT MESSAGE	DESCRIPTION	CHECK
427	SLAVE MODULE TEMPERATURE - OUT OF RANGE	The Slave Module (left controller) temperature sensor is out of the permitted range.	Refer problem to a qualified JLG mechanic.
428	MASTER MODULE TOO HOT - PLEASE WAIT	The Master Module (right controller) has reached thermal cutout.	<ul style="list-style-type: none"> • Power down and allow to cool. • Do not operate in ambients over 60°C (140°F). Refer problem to a qualified JLG mechanic.
429	SLAVE MODULE TOO HOT - PLEASE WAIT	The Slave Module (left controller) has reached thermal cutout.	<ul style="list-style-type: none"> • Power down and allow to cool. • Do not operate in ambients over 60°C (140°F). Refer problem to a qualified JLG mechanic.
4210	RIGHT DRIVE MOTOR TOO HOT - PLEASE WAIT	The right drive motor temperature is too high.	<ul style="list-style-type: none"> • Power down and allow to cool. • Do not operate in ambients over 60°C (140°F). Refer problem to a qualified JLG mechanic.
4211	LEFT DRIVE MOTOR TOO HOT - PLEASE WAIT	The left drive motor temperature is too high.	<ul style="list-style-type: none"> • Power down and allow to cool. • Do not operate in ambients over 60°C (140°F). Refer problem to a qualified JLG mechanic.
4212	RIGHT DRIVE MOTOR TEMPERATURE - OUT OF RANGE	A problem has been detected in this function.	Refer problem to a qualified JLG mechanic.

SECTION 5 – GENERAL SPECIFICATIONS AND MAINTENANCE

DTC	FAULT MESSAGE	DESCRIPTION	CHECK
4213	LEFT DRIVE MOTOR TEMPERATURE - OUT OF RANGE	A problem has been detected in this function.	Refer problem to a qualified JLG mechanic.

4-4 Battery Supply

DTC	FAULT MESSAGE	DESCRIPTION	CHECK
441	BATTERY VOLTAGE TOO LOW - SYSTEM SHUTDOWN	A problem has been detected with the batteries or power module.	<ul style="list-style-type: none">• Recharge batteries.• Check for damaged batteries, battery cables or connections.• Check battery charger function. Be sure to observe indicators for at least 30 seconds. Refer problem to a qualified JLG mechanic.
442	BATTERY VOLTAGE TOO HIGH - SYSTEM SHUTDOWN	A problem has been detected with the batteries or the power module.	May be due to improper battery charging or incorrect voltage batteries being used. Refer problem to a qualified JLG mechanic.

SECTION 5 – GENERAL SPECIFICATIONS AND MAINTENANCE

DTC	FAULT MESSAGE	DESCRIPTION	CHECK
4417	BATTERY POWER LOW	The batteries are discharged.	<ul style="list-style-type: none"> • Recharge batteries. • Check for damaged batteries, battery cables or connections. • Check battery charger function. Be sure to observe indicators for at least 30 seconds. Refer problem to a qualified JLG mechanic.
4418	MASTER MODULE VOLTAGE OUT OF RANGE	A problem has been detected with the batteries or power module.	<ul style="list-style-type: none"> • Recharge batteries. • Check for damaged batteries, battery cables or connections. • Check battery charger function. Be sure to observe indicators for at least 30 seconds. Refer problem to a qualified JLG mechanic.
4419	SLAVE MODULE VOLTAGE OUT OF RANGE	A problem has been detected with the batteries or power module.	<ul style="list-style-type: none"> • Recharge batteries. • Check for damaged batteries, battery cables or connections. • Check battery charger function. Be sure to observe indicators for at least 30 seconds. Refer problem to a qualified JLG mechanic.

SECTION 5 – GENERAL SPECIFICATIONS AND MAINTENANCE

DTC	FAULT MESSAGE	DESCRIPTION	CHECK
4420	BATTERY DEEPLY DISCHARGED	The batteries are deeply discharged.	<ul style="list-style-type: none"> • Recharge batteries. • Check for damaged batteries, battery cables or connections. • Check battery charger function. Be sure to observe indicators for at least 30 seconds. Refer problem to a qualified JLG mechanic.

4-6 Transmission and Drive System

DTC	FAULT MESSAGE	DESCRIPTION	CHECK
4610	RIGHT SPEED SENSOR - NOT RESPONDING PROPERLY	A problem has been detected with the right drive motor speed sensor (encoder).	Refer problem to a qualified JLG mechanic.
4611	LEFT SPEED SENSOR - NOT RESPONDING PROPERLY	A problem has been detected with the left drive motor speed sensor (encoder).	Refer problem to a qualified JLG mechanic.
4612	RIGHT SPEED SENSOR - RPM HIGH	Machine overspeed has been detected on the right motor.	<ul style="list-style-type: none"> • The machine should be driven at limited speed in ramps. Refer problem to a qualified JLG mechanic.
4613	LEFT SPEED SENSOR - RPM HIGH	Machine overspeed has been detected on the left motor.	<ul style="list-style-type: none"> • The machine should be driven at limited speed in ramps. Refer problem to a qualified JLG mechanic.

 **6-6 Communication**

DTC	FAULT MESSAGE	DESCRIPTION	CHECK
6632	CANBUS FAILURE - MASTER MODULE	The control system failed to receive messages from the Master Module (right controller).	Refer problem to a qualified JLG mechanic.
6633	CANBUS FAILURE - SLAVE MODULE	The control system failed to receive messages from the Slave Module (left controller).	Refer problem to a qualified JLG mechanic.
6634	CANBUS COMM LOST	The platform module failed to receive messages from both the master and the slave modules.	Refer problem to a qualified JLG mechanic.

 **6-7 Accessory**

DTC	FAULT MESSAGE	DESCRIPTION	CHECK
672	FUNCTIONS CUTOFF - SOFT TOUCH DETECTED	An obstacle has been detected by the soft touch device (if equipped).	<ul style="list-style-type: none"> • Clear the obstacle. Refer problem to a qualified JLG mechanic.
673	FUNCTIONS CUTOFF - GATE OPEN DETECTED	If equipped - Platform entry gate is detected open.	<ul style="list-style-type: none"> • Check if the Gate Limit Switches are damaged, obstructed or jammed. Refer problem to a qualified JLG mechanic.

SECTION 5 – GENERAL SPECIFICATIONS AND MAINTENANCE

7-7 Electric Motor

DTC	FAULT MESSAGE	DESCRIPTION	CHECK
7721	MASTER MODULE CAPACITOR BANK FAULT	There is a problem with the Master Module (right controller).	Refer problem to a qualified JLG mechanic.
7722	SLAVE MODULE CAPACITOR BANK FAULT	There is a problem with the Slave Module (left controller).	Refer problem to a qualified JLG mechanic.
7723	RIGHT MOTOR FEEDBACK FAILURE	The right motor voltage feedback circuits are damaged (Master Module).	Refer problem to a qualified JLG mechanic.
7724	LEFT MOTOR FEEDBACK FAILURE	The left motor voltage feedback circuits are damaged (Slave Module).	Refer problem to a qualified JLG mechanic.
7725	PUMP MOTOR - NOT RESPONDING	The pump motor feedback is not responding when the pump is being driven (by the Master Module).	Refer problem to a qualified JLG mechanic.
7726	RIGHT MOTOR OUTPUT-OUT OF RANGE HIGH	The right motor voltage output is higher than expected (Master Module).	Refer problem to a qualified JLG mechanic.
7727	LEFT MOTOR OUTPUT-OUT OF RANGE HIGH	The left motor voltage output is higher than expected (Slave Module).	Refer problem to a qualified JLG mechanic.
7728	RIGHT MOTOR OUTPUT-OUT OF RANGE LOW	The right motor voltage output is lower than expected (Master Module).	Refer problem to a qualified JLG mechanic.

SECTION 5 – GENERAL SPECIFICATIONS AND MAINTENANCE

DTC	FAULT MESSAGE	DESCRIPTION	CHECK
7729	LEFT MOTOR OUTPUT-OUT OF RANGE LOW	The left motor voltage output is lower than expected (Slave Module).	Refer problem to a qualified JLG mechanic.
7730	PUMP MOTOR OUTPUT-OUT OF RANGE HIGH	The pump motor voltage output is higher than expected (driven by the Master Module).	Refer problem to a qualified JLG mechanic.
7731	PUMP MOTOR OUTPUT-OUT OF RANGE LOW	The pump motor voltage output is lower than expected (driven by the Master Module).	Refer problem to a qualified JLG mechanic.
7732	STALLED RIGHT MOTOR	The right motor has been detected stalled.	<ul style="list-style-type: none"> • Ensure vehicle is not stuck on something preventing movement. Refer problem to a qualified JLG mechanic.
7733	STALLED LEFT MOTOR	The left motor has been detected stalled.	<ul style="list-style-type: none"> • Ensure vehicle is not stuck on something preventing movement. Refer problem to a qualified JLG mechanic.

8-1 Tilt Sensor

DTC	FAULT MESSAGE	DESCRIPTION	CHECK
815	CHASSIS TILT SENSOR DISAGREEMENT	Tilt sensor inputs to the control system are not the same state.	Refer problem to a qualified JLG mechanic.

SECTION 5 – GENERAL SPECIFICATIONS AND MAINTENANCE

8-2 Platform Load Sense

DTC	FAULT MESSAGE	DESCRIPTION	CHECK
825	LLS HAS NOT BEEN CALIBRATED	The Load Sensing System has not been calibrated.	Refer problem to a qualified JLG mechanic.
829	FUNCTIONS CUTOFF - PLATFORM OVERLOADED	The platform is overloaded and functions are restricted.	<ul style="list-style-type: none">• Unload the platform.• Check if the overload switch is obstructed or jammed. Refer problem to a qualified JLG mechanic.
8210	OVERLOAD SENSOR ERROR	Inconsistency in the overload sensor information.	<ul style="list-style-type: none">• Check if the overload switch is damaged. Refer problem to a qualified JLG mechanic.

8-6 Steering/Axle

DTC	FAULT MESSAGE	DESCRIPTION	CHECK
8664	STEER SENSOR - OUT OF RANGE HIGH	Invalid signal from the steer sensor.	<ul style="list-style-type: none">• Check the steer sensor for damage. Refer problem to a qualified JLG mechanic.
8665	STEER SENSOR - OUT OF RANGE LOW	Invalid signal from the steer sensor.	<ul style="list-style-type: none">• Check the steer sensor for damage.• Check the steer sensor is securely mounted. Refer problem to a qualified JLG mechanic.

SECTION 5 – GENERAL SPECIFICATIONS AND MAINTENANCE

DTC	FAULT MESSAGE	DESCRIPTION	CHECK
8666	STEER SENSOR - DECOUPLED	Invalid signal from the steer sensor.	<ul style="list-style-type: none"> • Check the steer sensor for damage. • Check that the steer sensor is securely mounted. Refer problem to a qualified JLG mechanic.
8667	STEER SENSOR - NOT RESPONDING	Invalid signal from the steer sensor.	<ul style="list-style-type: none"> • Check the steer sensor for damage. • Check that the steer sensor is securely mounted. Refer problem to a qualified JLG mechanic.
8668	STEER SENSOR - NOT CALIBRATED	The steering sensor has not been calibrated.	Refer problem to a qualified JLG mechanic.

8-7 Safety System Override

DTC	FAULT MESSAGE	DESCRIPTION	CHECK
873	MACHINE SAFETY SYSTEM OVERRIDE OCCURED	Machine Safety System Override has been used to override a Safety System or the Platform Operator station	<ul style="list-style-type: none"> • The record of the use of MSSO must be cleared. Refer problem to a qualified JLG mechanic.

SECTION 5 – GENERAL SPECIFICATIONS AND MAINTENANCE

9-9 Hardware

DTC	FAULT MESSAGE	DESCRIPTION	CHECK
9992	MASTER MODULE A/D FAILURE	There is an internal error in the Master Module (right controller).	<ul style="list-style-type: none">• Cycle power to clear the fault. Refer problem to a qualified JLG mechanic.
9993	SLAVE MODULE A/D FAILURE	There is an internal error in the Slave Module (left controller).	<ul style="list-style-type: none">• Cycle power to clear the fault. Refer problem to a qualified JLG mechanic.
9994	MASTER MODULE EEPROM FAILURE	There is an internal error in the Master Module (right controller).	<ul style="list-style-type: none">• Cycle power to clear the fault. Refer problem to a qualified JLG mechanic.
9995	SLAVE MODULE EEPROM FAILURE	There is an internal error in the Slave Module (left controller).	<ul style="list-style-type: none">• Cycle power to clear the fault. Refer problem to a qualified JLG mechanic.
9996	MASTER MODULE MEMORY FAILURE	There is an internal error in the Master Module (right controller).	<ul style="list-style-type: none">• Cycle power to clear the fault. Refer problem to a qualified JLG mechanic.
9997	SLAVE MODULE MEMORY FAILURE	There is an internal error in the Slave Module (left controller).	<ul style="list-style-type: none">• Cycle power to clear the fault. Refer problem to a qualified JLG mechanic.
9998	MASTER MODULE PROTECTION FAILURE	There is an internal error in the Master Module (right controller).	<ul style="list-style-type: none">• Cycle power to clear the fault. Refer problem to a qualified JLG mechanic.
9999	SLAVE MODULE PROTECTION FAILURE	There is an internal error in the Slave Module (left controller).	<ul style="list-style-type: none">• Cycle power to clear the fault. Refer problem to a qualified JLG mechanic.

SECTION 5 – GENERAL SPECIFICATIONS AND MAINTENANCE

DTC	FAULT MESSAGE	DESCRIPTION	CHECK
99100	MASTER MODULE FAILURE - CHECK POWER CIRCUITS OR MOSFET SHORT CIRCUIT	A short circuit on the power outputs of the Master Module (right controller) has been detected.	<ul style="list-style-type: none"> • Cycle power to clear the fault. Refer problem to a qualified JLG mechanic.
99101	SLAVE MODULE FAILURE - CHECK POWER CIRCUITS OR MOSFET SHORT CIRCUIT	A short circuit on the power outputs of the Slave Module (left controller) has been detected.	<ul style="list-style-type: none"> • Cycle power to clear the fault. Refer problem to a qualified JLG mechanic.
99102	MASTER MODULE WATCHDOG RESET	There is an internal error in the Master Module (right controller).	<ul style="list-style-type: none"> • Cycle power to clear the fault. Refer problem to a qualified JLG mechanic.
99103	SLAVE MODULE WATCHDOG RESET	There is an internal error in the Slave Module (left controller).	<ul style="list-style-type: none"> • Cycle power to clear the fault. Refer problem to a qualified JLG mechanic.
99104	MASTER MODULE WATCHDOG2 RESET	There is an internal error in the Master Module (right controller).	<ul style="list-style-type: none"> • Cycle power to clear the fault. Refer problem to a qualified JLG mechanic.
99105	SLAVE MODULE WATCHDOG2 RESET	There is an internal error in the Slave Module (left controller).	<ul style="list-style-type: none"> • Cycle power to clear the fault. Refer problem to a qualified JLG mechanic.
99106	MASTER MODULE RAM FAILURE	There is an internal error in the Master Module (right controller).	<ul style="list-style-type: none"> • Cycle power to clear the fault. Refer problem to a qualified JLG mechanic.
99107	SLAVE MODULE RAM FAILURE	There is an internal error in the Slave Module (left controller).	<ul style="list-style-type: none"> • Cycle power to clear the fault. Refer problem to a qualified JLG mechanic.

SECTION 5 – GENERAL SPECIFICATIONS AND MAINTENANCE

DTC	FAULT MESSAGE	DESCRIPTION	CHECK
99108	MASTER MODULE - INTERNAL ERROR	There is an internal error in the Master Module (right controller).	<ul style="list-style-type: none">• Cycle power to clear the fault. Refer problem to a qualified JLG mechanic.
99109	SLAVE MODULE - INTERNAL ERROR	There is an internal error in the Slave Module (left controller).	<ul style="list-style-type: none">• Cycle power to clear the fault. Refer problem to a qualified JLG mechanic.
99110	MASTER MODULE - INTERNAL ERROR	There is an internal error in the Master Module (right controller).	<ul style="list-style-type: none">• Cycle power to clear the fault. Refer problem to a qualified JLG mechanic.
99111	SLAVE MODULE - INTERNAL ERROR	There is an internal error in the Slave Module (left controller).	<ul style="list-style-type: none">• Cycle power to clear the fault. Refer problem to a qualified JLG mechanic.
99112	MASTER MODULE - INTERNAL ERROR	There is an internal error in the Master Module (right controller).	<ul style="list-style-type: none">• Cycle power to clear the fault. Refer problem to a qualified JLG mechanic.
99114	MASTER MODULE - INTERNAL ERROR	There is an internal error in the Master Module (right controller).	<ul style="list-style-type: none">• Cycle power to clear the fault. Refer problem to a qualified JLG mechanic.
99115	SLAVE MODULE - INTERNAL ERROR	There is an internal error in the Slave Module (left controller).	<ul style="list-style-type: none">• Cycle power to clear the fault. Refer problem to a qualified JLG mechanic.
99116	MASTER MODULE - INTERNAL ERROR	There is an internal error in the Master Module (right controller).	<ul style="list-style-type: none">• Cycle power to clear the fault. Refer problem to a qualified JLG mechanic.
99117	SLAVE MODULE - INTERNAL ERROR	There is an internal error in the Slave Module (left controller).	<ul style="list-style-type: none">• Cycle power to clear the fault. Refer problem to a qualified JLG mechanic.

SECTION 5 – GENERAL SPECIFICATIONS AND MAINTENANCE

DTC	FAULT MESSAGE	DESCRIPTION	CHECK
99118	MASTER MODULE - INTERNAL ERROR	There is an internal error in the Master Module (right controller).	<ul style="list-style-type: none"> • Cycle power to clear the fault. Refer problem to a qualified JLG mechanic.
99119	SLAVE MODULE - INTERNAL ERROR	There is an internal error in the Slave Module (left controller).	<ul style="list-style-type: none"> • Cycle power to clear the fault. Refer problem to a qualified JLG mechanic.
99120	MASTER MODULE - INTERNAL ERROR	There is an internal error in the Master Module (right controller).	<ul style="list-style-type: none"> • Cycle power to clear the fault. Refer problem to a qualified JLG mechanic.
99121	SLAVE MODULE - INTERNAL ERROR	There is an internal error in the Slave Module (left controller).	<ul style="list-style-type: none"> • Cycle power to clear the fault. Refer problem to a qualified JLG mechanic.
99122	MASTER MODULE - INTERNAL ERROR	There is an internal error in the Master Module (right controller).	<ul style="list-style-type: none"> • Cycle power to clear the fault. Refer problem to a qualified JLG mechanic.
99123	SLAVE MODULE - INTERNAL ERROR	There is an internal error in the Slave Module (left controller).	<ul style="list-style-type: none"> • Cycle power to clear the fault. Refer problem to a qualified JLG mechanic.
99124	MASTER MODULE - INTERNAL ERROR	There is an internal error in the Master Module (right controller).	<ul style="list-style-type: none"> • Cycle power to clear the fault. Refer problem to a qualified JLG mechanic.
99125	MASTER MODULE - INTERNAL ERROR	There is an internal error in the Master Module (right controller).	<ul style="list-style-type: none"> • Cycle power to clear the fault. Refer problem to a qualified JLG mechanic.
99126	MASTER MODULE - INTERNAL ERROR	There is an internal error in the Master Module (right controller).	<ul style="list-style-type: none"> • Cycle power to clear the fault. Refer problem to a qualified JLG mechanic.

SECTION 5 – GENERAL SPECIFICATIONS AND MAINTENANCE

DTC	FAULT MESSAGE	DESCRIPTION	CHECK
99127	MASTER MODULE - INTERNAL ERROR	There is an internal error in the Master Module (right controller).	<ul style="list-style-type: none">• Cycle power to clear the fault. Refer problem to a qualified JLG mechanic.
99128	MASTER MODULE - INTERNAL ERROR	There is an internal error in the Master Module (right controller).	<ul style="list-style-type: none">• Cycle power to clear the fault. Refer problem to a qualified JLG mechanic.
99129	MASTER MODULE - INTERNAL ERROR	There is an internal error in the Master Module (right controller).	<ul style="list-style-type: none">• Cycle power to clear the fault. Refer problem to a qualified JLG mechanic.
99130	MASTER MODULE - INTERNAL ERROR	There is an internal error in the Master Module (right controller).	<ul style="list-style-type: none">• Cycle power to clear the fault. Refer problem to a qualified JLG mechanic.
99131	MASTER MODULE - INTERNAL ERROR	There is an internal error in the Master Module (right controller).	<ul style="list-style-type: none">• Cycle power to clear the fault. Refer problem to a qualified JLG mechanic.
99132	MASTER MODULE - INTERNAL ERROR	There is an internal error in the Master Module (right controller).	<ul style="list-style-type: none">• Cycle power to clear the fault. Refer problem to a qualified JLG mechanic.
99133	MASTER MODULE - INTERNAL ERROR	There is an internal error in the Master Module (right controller).	<ul style="list-style-type: none">• Cycle power to clear the fault. Refer problem to a qualified JLG mechanic.

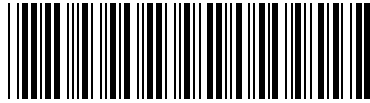

31210224



An Oshkosh Corporation Company

***Corporate Office
JLG Industries, Inc.***

1 JLG Drive

McConnellsburg, PA 17233-9533 USA

☎ (717) 485-5161 (Corporate)

☎ (877) 554-5438 (Customer Support)

☎ (717) 485-6417

Visit our website for JLG Worldwide Locations.

www.jlg.com