



Operator's Manual

Z-60/34

CE

with
Maintenance
Information

Seventh Edition
First Printing
Part No. 133083

Important

Read, understand and obey these safety rules and operating instructions before operating this machine. Only trained and authorized personnel shall be permitted to operate this machine. This manual should be considered a permanent part of your machine and should remain with the machine at all times. If you have any questions, call Genie Industries.

Contents

	Page
Introduction	1
Symbol and Hazard Pictorial Definitions	3
General Safety	5
Personal Safety	8
Work Area Safety	9
Legend	17
Controls	18
Inspections	25
Operating Instructions	36
Transport and Lifting Instructions	46
Maintenance	49
Specifications	53

Contact us:

Internet: www.genielift.com
 E-mail: techpub@genieind.com

Copyright © 1993 by Genie Industries

First Edition: First Printing, February 1993
 Second Edition: Third Printing, September 1996
 Third Edition: Sixth Printing, November 2001
 Fourth Edition: First Printing, July 2002
 Fifth Edition: Second Printing, August 2004
 Sixth Edition: Second Printing, June 2006
 Seventh Edition: First Printing, December 2007
 "Genie" and "Z" are registered trademarks of Genie Industries in the U.S.A. and many other countries.

 Printed on recycled paper

Printed in U.S.A.

Introduction

Owners, Users and Operators:

Genie appreciates your choice of our machine for your application. Our number one priority is user safety, which is best achieved by our joint efforts. We feel that you make a major contribution to safety if you, as the equipment users and operators:

- 1 **Comply** with employer, job site and governmental rules.
- 2 **Read, understand and follow** the instructions in this and other manuals supplied with this machine.
- 3 **Use good safe work practices** in a commonsense way.
- 4 **Only have trained/certified operators**, directed by informed and knowledgeable supervision, running the machine.

If there is anything in this manual that is not clear or which you believe should be added, please contact us.

Internet: www.genielift.com

E-mail: techpub@genieind.com



Danger

Failure to obey the instructions and safety rules in this manual will result in death or serious injury.

Do Not Operate Unless:

- You learn and practice the principles of safe machine operation contained in this operator's manual.
 - 1 **Avoid hazardous situations.**

Know and understand the safety rules before going on to the next section.

 - 2 Always perform a pre-operation inspection.
 - 3 Always perform function tests prior to use.
 - 4 Inspect the workplace.
 - 5 Only use the machine as it was intended.
- You read, understand and obey the manufacturer's instructions and safety rules—safety and operator's manuals and machine decals.
- You read, understand and obey employer's safety rules and worksite regulations.
- You read, understand and obey all applicable governmental regulations.
- You are properly trained to safely operate the machine.

Introduction

Hazard Classification

Genie uses symbols, color coding and signal words to identify the following:



Safety alert symbol—used to alert you to potential personal injury hazards. Obey all safety messages that follow this symbol to avoid possible injury or death.

▲ DANGER

Red

Indicates a hazardous situation which, if not avoided, will result in death or serious injury.

▲ WARNING

Orange

Indicates a hazardous situation which, if not avoided, could result in death or serious injury.

▲ CAUTION

Yellow

Indicates a hazardous situation which, if not avoided, could result in minor or moderate injury.

NOTICE

Blue

Indicates a hazardous situation which, if not avoided, could result in property damage.

Intended Use

This machine is intended to be used only to lift personnel, along with their tools and materials to an aerial work site.











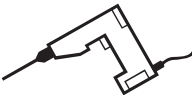
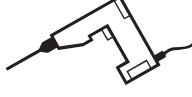

Safety Sign Maintenance

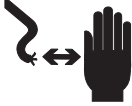
Replace any missing or damaged safety signs. Keep operator safety in mind at all times. Use mild soap and water to clean safety signs. Do not use solvent-based cleaners because they may damage the safety sign material.

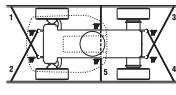
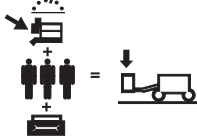
Symbol and Hazard Pictorials Definitions

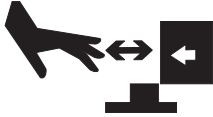
 Crush Hazard	 Explosion Hazard	 Fire Hazard	 Explosion Hazard	 Electrocution Hazard
 Fall Hazard	 Crush Hazard	 Tip-over Hazard	 Tip-over Hazard	 Tip-over Hazard
 Tip-over Hazard	 Tip-over Hazard	 Electrocution Hazard	 Read service manual	 Rated platform capacity
 Keep off this surface.	 Keep away from moving parts.	 Maintain required clearance.	 Keep away from path of moving platform.	 Only trained maintenance personnel should access compartments
 Read the operator's manual.	 No smoking. No flame. Stop engine.	<p>Recovery procedure if tilt alarm sounds while elevated.</p>  <p>Platform uphill: 1 Lower primary 2 Lower secondary 3 Retract primary</p>  <p>Platform downhill: 1 Retract primary 2 Lower secondary 3 Lower primary</p>		 Do not use ether or other high energy starting aids on machines equipped with glow plugs.

Symbol and Hazard Pictorials Definitions

 <p>Lanyard attachment point</p>	 <p>Wheelload</p>	 <p>Voltage rating for power to platform</p>	 <p>Pressure rating for air line to platform</p>	 <p>Fire extinguisher</p>
 <p>Avoid contact.</p>	 <p>Tie-down instructions</p>	 <p>Tie-down instructions</p>	 <p>Weight of welder reduces capacity</p>	 <p>Wind speed</p>
 <p>Turntable lock can shear.</p>	 <p>Keep away from moving parts.</p>	 <p>Collision hazard</p>	 <p>Keep away from moving parts.</p>	 <p>Tire pressure</p>

General Safety

Safety signs and locations

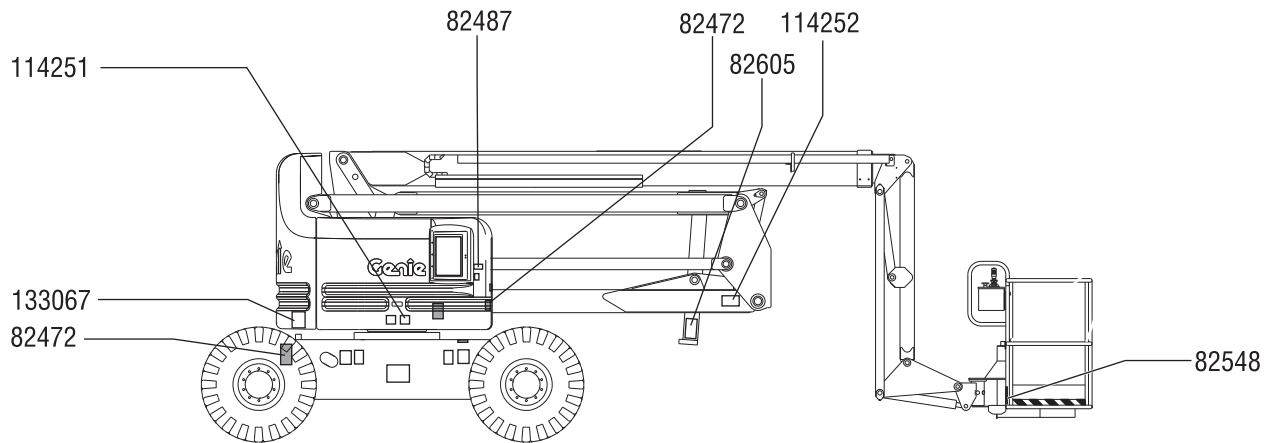

114252



82487



114251



133067



82472



82548



82605



General Safety

Safety signs and locations

82487



114248



82601



82606



82604

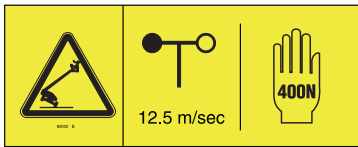

82671

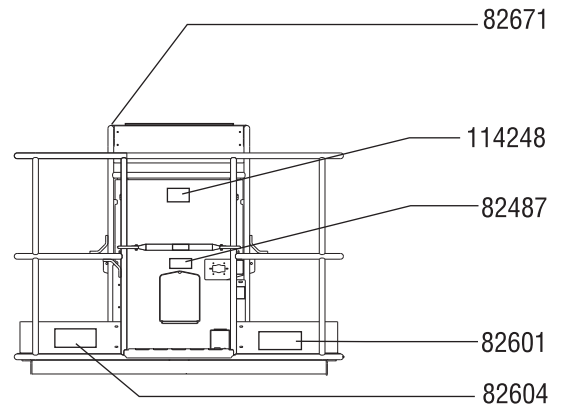
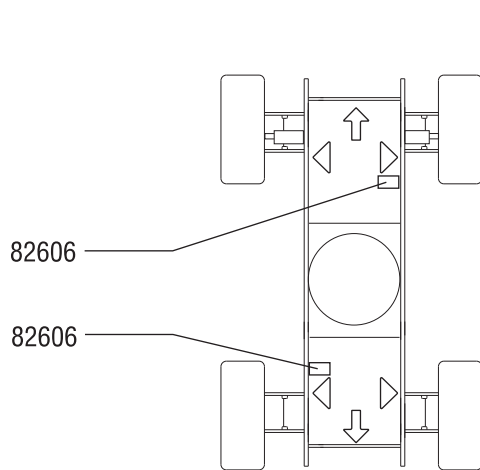

General Safety

Safety signs and locations

114247



82548



82472



114252



133067



82473



82605



82671

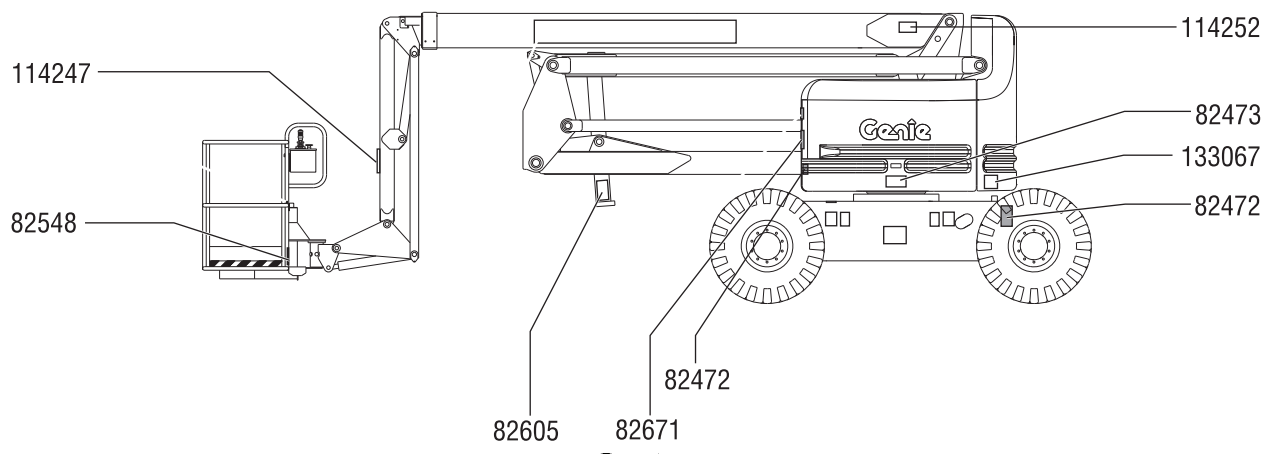

Personal Safety

Fall Protection

Personal fall protection equipment (PFPE) is required when operating this machine.

Occupants must wear a safety belt or harness in accordance with governmental regulations. Attach the lanyard to the anchor provided in the platform.

Operators must comply with employer, job site and governmental rules regarding the use of personal protective equipment.

All PFPE must comply with applicable governmental regulations, and must be inspected and used in accordance with the PFPE manufacturer's instructions.

Work Area Safety

⚠ Electrocuting Hazards

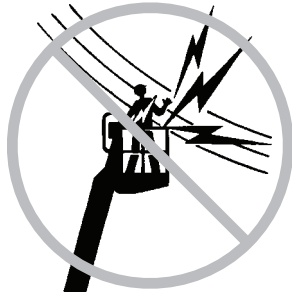

This machine is not electrically insulated and will not provide protection from contact with or proximity to electrical current.

Maintain safe distances from electrical power lines and apparatus in accordance with applicable governmental regulations and the following chart.

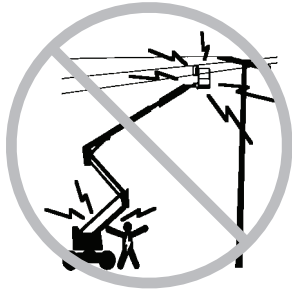

Line Voltage	Required Clearance
0 to 50KV	3.0 m
50 to 200KV	4.6 m
200 to 350KV	6.1 m
350 to 500KV	7.6 m
500 to 750KV	10.6 m
750 to 1000KV	13.7 m

Allow for platform movement, electrical line sway or sag and beware of strong or gusty winds.

Keep away from the machine if it contacts energized power lines. Personnel on the ground or in the platform must not touch or operate the machine until energized power lines are shut off.

Do not use the machine as a ground for welding.

Do not operate the machine during lightning or storms.

⚠ Tip-over Hazards

Occupants, equipment and materials shall not exceed the maximum platform capacity.

Maximum platform capacity	227 kg
Maximum occupants	2

The weight of options and accessories, such as pipe cradles, panel cradles and welders, will reduce the rated platform capacity and must be factored into the total platform load. See the decals with the options.

If using accessories, read, understand and obey the decals and instructions with the accessory.

Work Area Safety

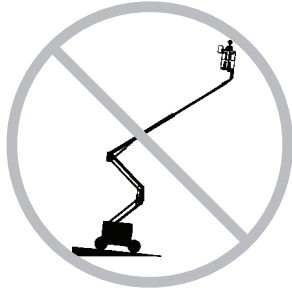

Do not raise or extend the boom unless the machine is on a firm, level surface.

Do not depend on the tilt alarm as a level indicator. The tilt alarm sounds in the platform only when the machine is on a severe slope.

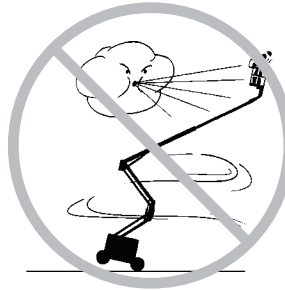

Do not raise the boom when wind speeds may exceed 12.5 m/s. If wind speeds exceed 12.5 m/s when the boom is raised, lower the boom and do not continue to operate the machine.

Do not operate the machine in strong or gusty winds. Do not increase the surface area of the platform or the load. Increasing the area exposed to the wind will decrease machine stability.



If the tilt alarm sounds while the boom is lowered: Do not extend, rotate or raise the boom above horizontal. Move the machine to a firm, level surface before raising the platform.

If the tilt alarm sounds when the platform is raised: Use extreme caution. Identify the condition of the boom on the slope as shown below. Follow the steps to lower the boom before moving to a firm, level surface. Do not rotate the boom while lowering.

If the tilt alarm sounds with the platform uphill:

- 1 Lower the primary boom.
- 2 Lower the secondary boom.
- 3 Retract the primary boom.

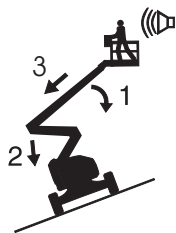

If the tilt alarm sounds with the platform downhill:

- 1 Retract the primary boom.
- 2 Lower the secondary boom.
- 3 Lower the primary boom.

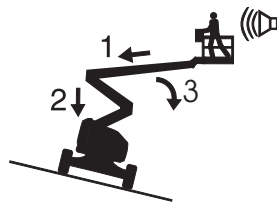

Use extreme care and slow speeds while driving the machine in the stowed position across uneven terrain, debris, unstable or slippery surfaces and near holes and drop-offs.

Do not drive the machine on or near uneven terrain, unstable surfaces or other hazardous conditions with the boom raised or extended.

Do not use the machine as a crane.

Do not push the machine or other objects with the boom.

Do not contact adjacent structures with the boom.

Do not tie the boom or platform to adjacent structures.

Do not place loads outside the platform perimeter.

Work Area Safety

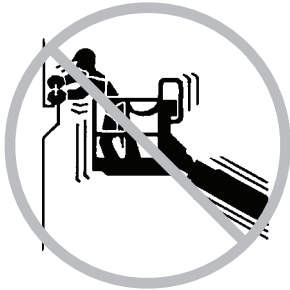

Do not push off or pull toward any object outside of the platform.

Maximum allowable manual force
400 N

Do not alter or disable machine components that in any way affect safety and stability.

Do not replace items critical to machine stability with items of different weight or specification.

Do not replace factory-installed tires with tires of different specification or ply rating.

Do not modify or alter an aerial work platform without prior written permission from the manufacturer. Mounting attachments for holding tools or other materials onto the platform, toeboards or guard rail system can increase the weight in the platform and the surface area of the platform or the load.



Do not place or attach overhanging loads to any part of this machine.

Do not place ladders or scaffolds in the platform or against any part of this machine.



Do not transport tools and materials unless they are evenly distributed and can be safely handled by person(s) in the platform.

Do not use the machine on a moving or mobile surface or vehicle.

Be sure all tires are in good condition, air-filled tires are properly inflated and lug nuts are properly tightened.

Do not use the platform controls to free a platform that is caught, snagged or otherwise prevented from normal motion by an adjacent structure. All personnel must be removed from the platform before attempting to free the platform using the ground controls.

Work Area Safety

⚠ Operation on Slopes Hazards

Do not drive the machine on a slope that exceeds the maximum uphill, downhill or side slope rating of the machine. Slope rating applies only to machines in the stowed position.

Maximum slope rating, stowed position, 2WD

Platform downhill	25% (14°)
Platform uphill	20% (11°)
Side slope	25% (14°)

Maximum slope rating, stowed position, 4WD

Platform downhill	40% (22°)
Platform uphill	30% (17°)
Side slope	25% (14°)

Note: Slope rating is subject to ground conditions and adequate traction. See Driving on a Slope in the Operating Instructions Section.

⚠ Fall Hazards

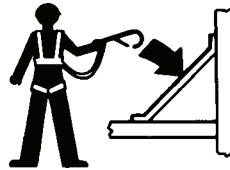

Occupants must wear a safety belt or harness in accordance with governmental regulations. Attach the lanyard to the anchor provided in the platform.



Do not sit, stand or climb on the platform guard rails. Maintain a firm footing on the platform floor at all times.



Do not climb down from the platform when raised.

Keep the platform floor clear of debris.

Lower the platform entry mid-rail or close the entry gate before operating.

Do not enter or exit the platform unless the machine is in the stowed position and the platform is at ground level.

Work Area Safety

⚠ Collision Hazards



Be aware of limited sight distance and blind spots when driving or operating.

Be aware of the boom position and tailswing when rotating the turntable.



Check the work area for overhead obstructions or other possible hazards.

Be aware of crushing hazards when grasping the platform guard rail.



Operators must comply with employer, job site and governmental rules regarding the use of personal protective equipment.

Observe and use the color-coded direction arrows on the platform controls and drive chassis for drive and steer functions.

Do not operate a boom in the path of any crane unless the controls of the crane have been locked out and/or precautions have been taken to prevent any potential collision.



No stunt driving or horseplay while operating a machine.

Do not lower the boom unless the area below is clear of personnel and obstructions.



Limit travel speed according to the condition of the ground surface, congestion, slope, location of personnel, and any other factors which may cause collision.

⚠ Bodily Injury Hazard

Do not operate the machine with a hydraulic oil or air leak. An air leak or hydraulic leak can penetrate and/or burn skin.

Always operate the machine in a well-ventilated area to avoid carbon monoxide poisoning.

Improper contact with components under any cover will cause serious injury. Only trained maintenance personnel should access compartments. Access by the operator is only advised when performing a pre-operation inspection. All compartments must remain closed and secured during operation.

Work Area Safety

⚠ Explosion and Fire Hazards

Do not start the engine if you smell or detect liquid petroleum gas (LPG), gasoline, diesel fuel or other explosive substances.

Do not refuel the machine with the engine running.

Refuel the machine and charge the battery only in an open, well-ventilated area away from sparks, flames and lighted tobacco.

Do not operate the machine in hazardous locations or locations where potentially flammable or explosive gases or particles may be present.

Do not spray ether into engines equipped with glow plugs.

⚠ Damaged Machine Hazards

Do not use a damaged or malfunctioning machine.

Conduct a thorough pre-operation inspection of the machine and test all functions before each work shift. Immediately tag and remove from service a damaged or malfunctioning machine.

Be sure all maintenance has been performed as specified in this manual and the appropriate Genie service manual.

Be sure all decals are in place and legible.

Be sure the operator's, safety and responsibilities manuals are complete, legible and in the storage container located on the platform.

⚠ Component Damage Hazards

Do not use any battery or charger greater than 12V to jump-start the engine.

Do not use the machine as a ground for welding.

⚠ Battery Safety

Burn Hazards



Batteries contain acid. Always wear protective clothing and eye wear when working with batteries.



Avoid spilling or contacting battery acid. Neutralize battery acid spills with baking soda and water.

Explosion Hazard



Keep sparks, flames and lighted tobacco away from batteries. Batteries emit explosive gas.

Electrocution Hazard

Avoid contact with electrical terminals.

Work Area Safety

▲ Pipe Cradle Safety

Read, understand and obey all warnings and instructions provided with the pipe cradles.

Do not exceed the rated platform capacity. The pipe cradle assembly and the weight in the pipe cradles will reduce rated platform capacity and must be factored into total platform load.

The pipe cradle assembly weighs 9.5 kg.

The maximum capacity of the pipe cradle assembly is 91 kg.

The weight of the pipe cradle assembly and the load in the pipe cradles may limit the maximum number of occupants in platform.

Center the load within the perimeter of the platform.

Secure the load to the platform.

Do not obstruct the entrance or the exit of the platform.

Do not obstruct the ability to operate the platform controls or the red Emergency Stop button.

Do not operate unless you are adequately instructed and are aware of all of the hazards associated with movement of the platform with an overhanging load.

Do not cause a horizontal force or side load to the machine by raising or lowering a fixed or overhanging load.

Electrocution Hazard: Keep pipes away from all energized electrical conductors.

▲ Panel Cradle Safety

Read, understand and obey all warnings and instructions provided with the panel cradles.

Do not exceed the rated platform capacity. The combined weight of the cradles, panels, occupants, tools and any other equipment must not exceed rated capacity.

The panel cradle assembly weighs 13.6 kg.

The maximum capacity of the panel cradles is 113 kg.

The weight of the panel cradles and the load in the panel cradles may limit the maximum number of occupants in platform to one person.

Secure the cradles to the platform. Secure the panel(s) to the platform railing using the straps provided.

Do not operate unless you are adequately instructed and are aware of all hazards associated with lifting panels.

Do not cause a horizontal force or side load to machine by raising or lowering a fixed or overhanging load.

Maximum vertical height of panels: 1.2 m

Maximum panel area: 3 m²

Work Area Safety

⚠ Welder Safety

Read, understand and obey all warnings and instructions provided with the welding power unit.

Do not connect weld leads or cables unless the welding power unit is turned off at the platform controls.

Do not operate unless the weld cables are properly connected and the welder is properly grounded.

The weight of the welder will reduce the rated platform capacity and must be factored into the total platform load. The welder power supply weighs 34 kg.

Do not operate the welder unless a fire extinguisher is immediately available for instant use, per OSHA regulation 1926.352(d).

⚠ Weld Line to Platform Safety

Read, understand and obey all warnings and instructions provided with the welding power unit.

Do not connect weld leads or cables unless the welding power unit is turned off at the platform controls.

Do not operate unless the weld cables are properly connected.

Connect the positive lead to the twist-lock connector at the turntable and platform.

Clamp the negative lead to the ground post at the turntable and platform.

Lockout After Each Use

- 1 Select a safe parking location—firm level surface, clear of obstruction and traffic.
- 2 Retract and lower the boom to the stowed position.
- 3 Rotate the turntable so that the boom is between the non-steer wheels.
- 4 Turn the key switch to the off position and remove the key to secure from unauthorized use.
- 5 Chock the wheels.

Legend

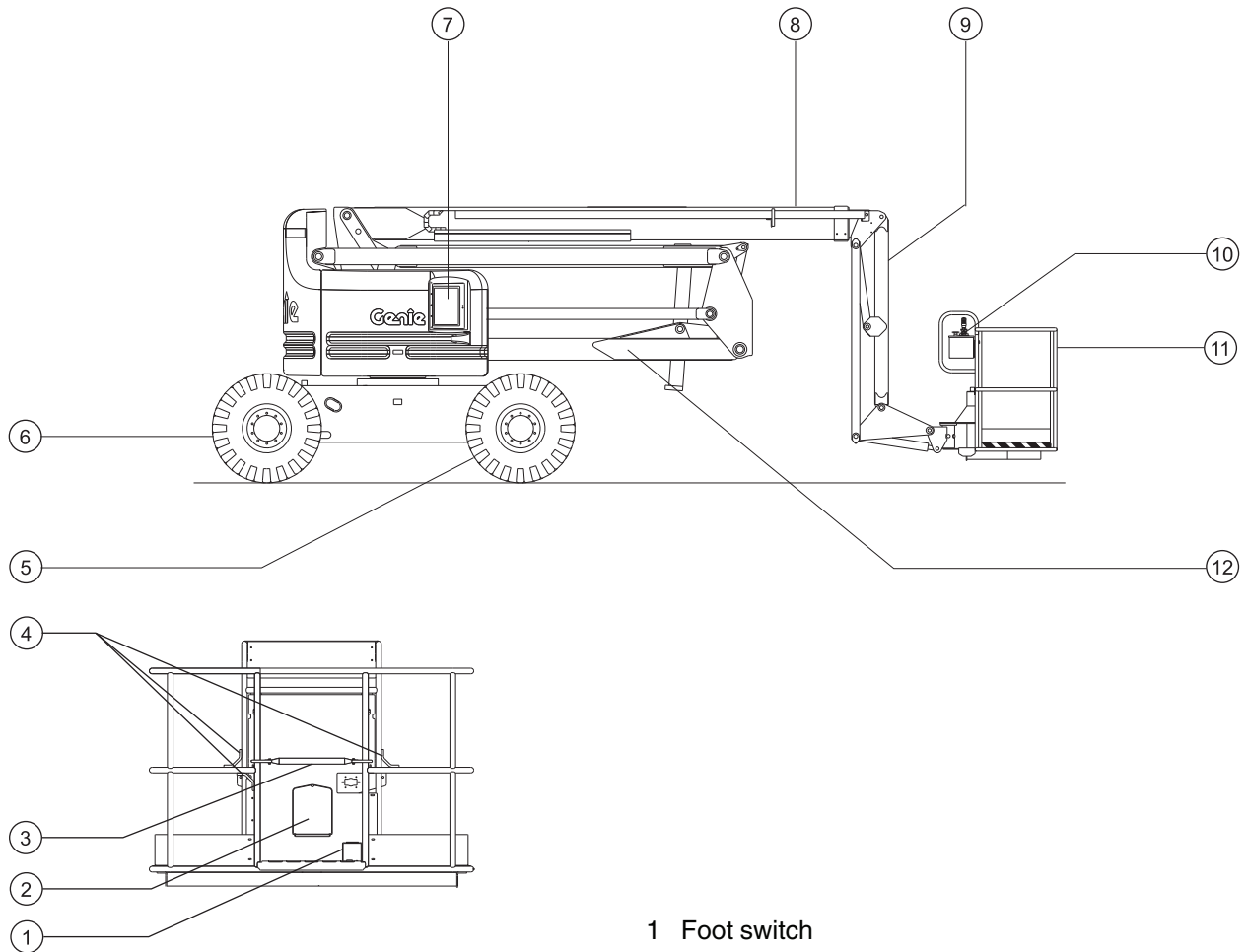

- 1 Foot switch
- 2 Manual storage container
- 3 Sliding mid rail
- 4 Lanyard anchorage point
- 5 Non- steer tire
- 6 Steer tire
- 7 Ground controls
- 8 Primary boom
- 9 Jib boom
- 10 Platform controls
- 11 Platform
- 12 Secondary boom

Controls

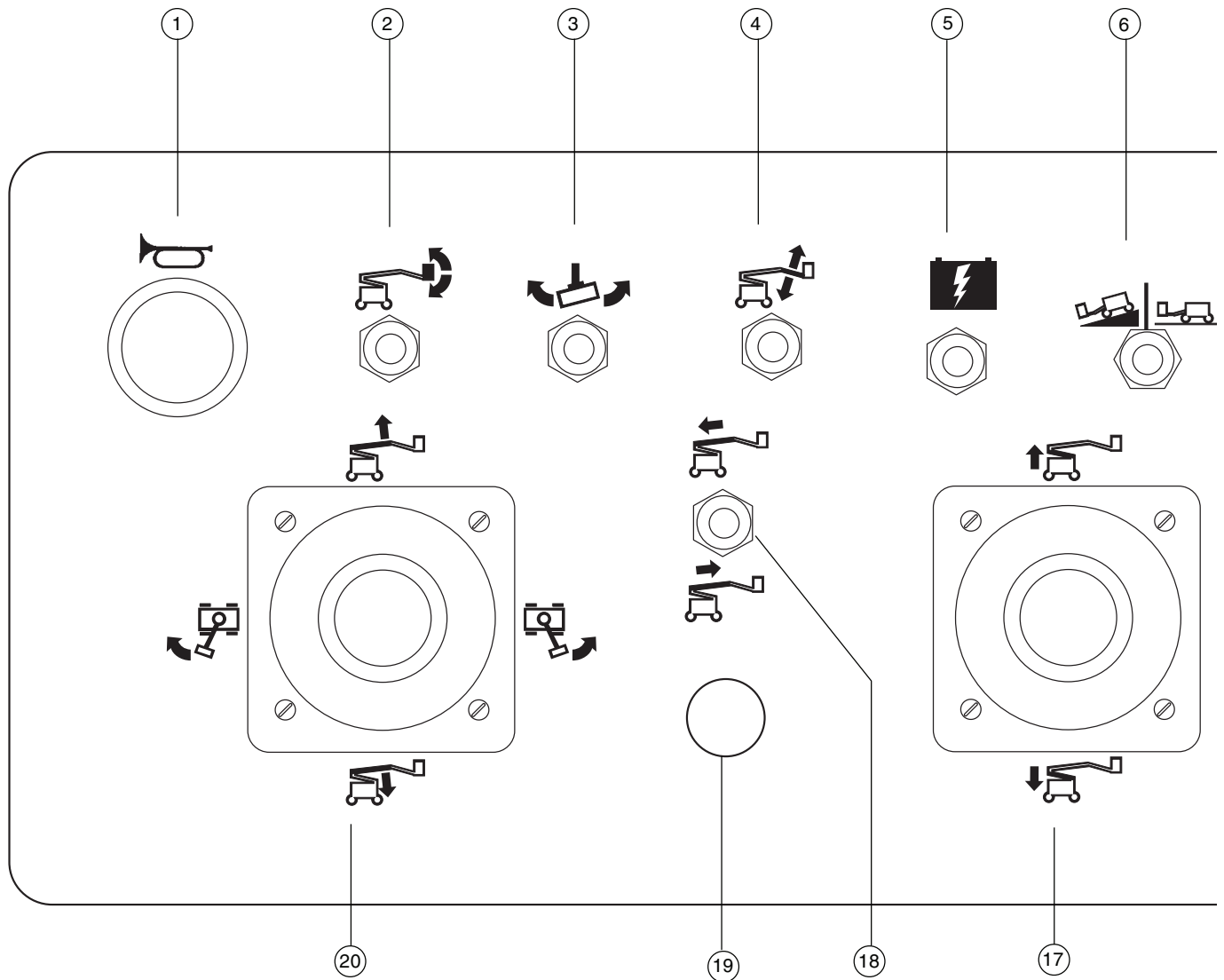

Platform Control Panel

- | | |
|---|--|
| <ul style="list-style-type: none"> 1 Horn button 2 Platform level switch 3 Platform rotate switch 4 Jib boom up/down switch 5 Auxiliary power switch 6 Drive speed select switch 7 Glow plug switch (option) | <ul style="list-style-type: none"> 8 Engine start switch 9 Engine idle (rpm) control switch <ul style="list-style-type: none"> - Turtle symbol: low idle - Rabbit symbol: high idle 10 Gasoline/LPG models: Gasoline/LPG select switch 11 Red Emergency Stop button |
|---|--|

Controls

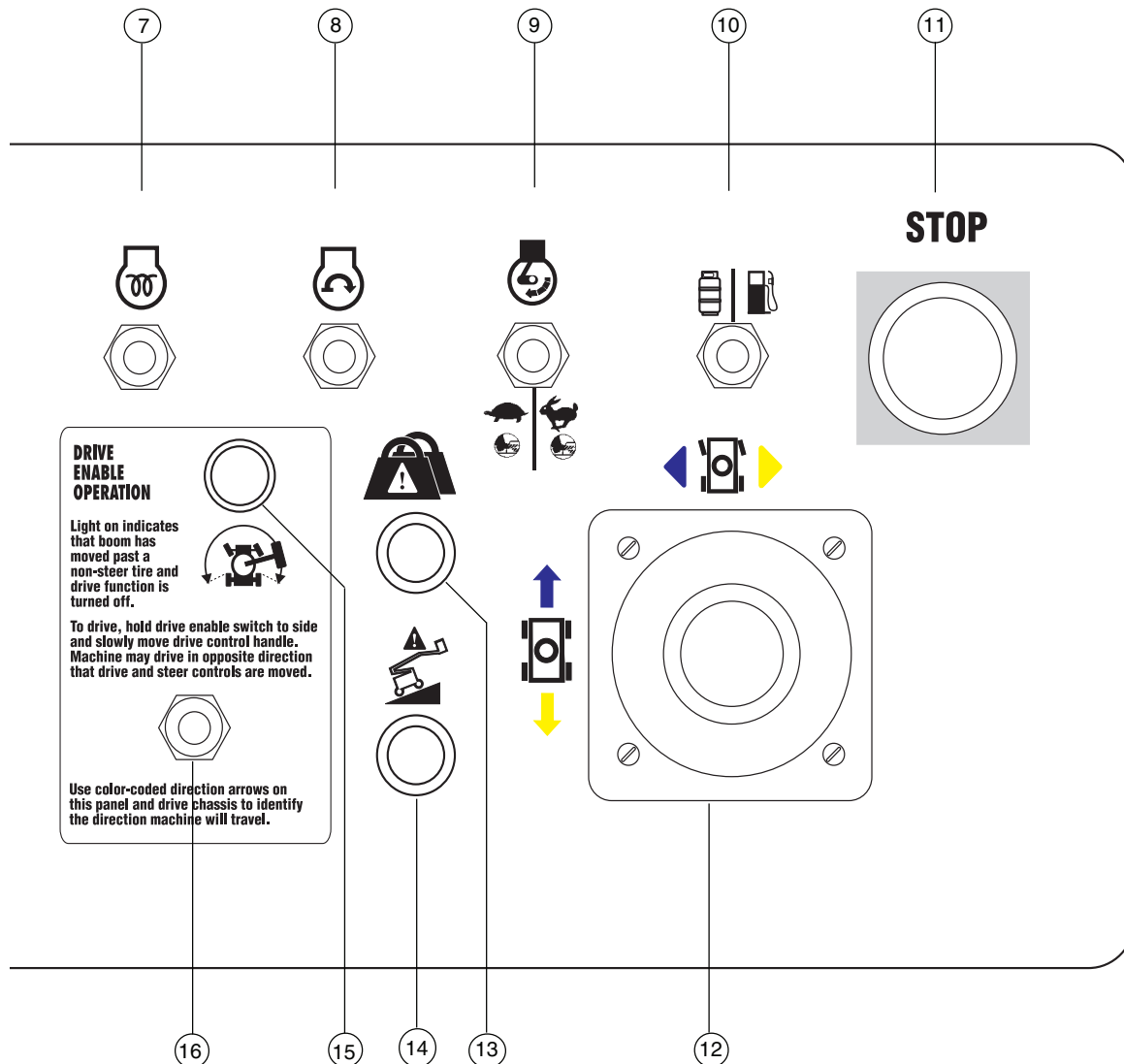

- 12 Proportional control handle for drive function and thumb rocker for steer function
OR dual axis proportional control handle for drive and steer functions
- 13 Platform overload indicator light
- 14 Machine not level indicator light (if equipped)
- 15 Drive enable indicator light
- 16 Drive enable switch

- 17 Proportional control handle for secondary boom up/down function
- 18 Primary boom extend/retract switch
- 19 Optional equipment
- 20 Dual axis proportional control handle for primary boom up/down and turntable rotate left/right functions

Controls

Platform Control Panel

1 Horn button

Push the horn button and the horn will sound.
Release the horn button and the horn will stop.

2 Platform level switch

Move the platform level switch up and the level of the platform will raise.
Move the platform level switch down and the level of the platform will lower.



3 Platform rotate switch

Move the platform rotate switch to the right and the platform will rotate to the right. Move the platform rotate switch to the left and the platform will rotate to the left.

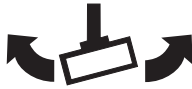

4 Jib boom up/down switch

Move the jib boom switch up and the jib boom will raise.
Move the jib boom switch down and the jib boom will lower.



5 Auxiliary power switch

Use auxiliary power if the primary power source (engine) fails.
Simultaneously hold the auxiliary power switch to either side and activate the desired function.

6 Drive speed select switch

Machine on incline symbol: Low range operation for inclines.

Machine on level surface symbol: High range operation for maximum drive speed.

7 Glow plug switch

Move the glow plug switch to either side and hold for 3 to 5 seconds.

8 Engine start switch

Move the engine start switch to either side to start the engine.

9 Engine idle (rpm) select switch

Move the engine idle select switch to the turtle position for foot switch activated low idle.

Move the engine idle select switch to the rabbit position for foot switch activated high idle.

10 Gasoline/LPG models: Fuel select switch

Move the fuel select switch to the gasoline position to select gasoline. Move the fuel select switch to the LPG position to select LPG.

11 Red Emergency Stop button

Push in red Emergency Stop button to the off position to stop all functions and turn the engine off. Pull out the red Emergency Stop button to the on position to operate the machine.

Controls

12 Dual axis proportional control handle for drive and steer functions

OR Proportional control handle for drive function and thumb rocker for steer function

Move the control handle in the direction indicated by the blue arrow on the control panel and the machine will drive forward. Move the control handle in the direction indicated by the yellow arrow and the machine will drive backwards. Move the control handle in the direction indicated by the blue triangle and the machine will steer to the left. Move the control handle in the direction indicated by the yellow triangle and the machine will steer to the right.

OR
Move the control handle in the direction indicated by the blue arrow on the control panel and the machine will drive forward. Move the control handle in the direction indicated by the yellow arrow and the machine will drive backwards. Press the left side of the thumb rocker and the machine will steer to the left. Press the right side of the thumb rocker and the machine will steer to the right.

13 Platform overload indicator light

Light flashing indicates the platform is overloaded and no functions will operate. Remove weight until the light goes off.

14 Machine not level indicator light (if equipped)

The machine not level indicator light will come on when the tilt alarm sounds.

15 Drive enable indicator light

Light on indicates that the boom has moved just past either non-steer wheel and drive function has been interrupted.

16 Drive enable switch

To drive when the drive enable light is on, hold the drive enable switch to either side and slowly move the drive control handle off center. Be aware that the machine may move in the opposite direction that the drive and steer controls are moved.

17 Proportional control handle for secondary boom up/down function

Move the control handle up and the secondary boom will raise. Move the control handle down and the secondary boom will lower.



18 Primary boom extend/retract switch

Move the primary boom switch up and the primary boom will retract. Move the primary boom switch down and the primary boom will extend.



19 Used for optional equipment

20 Dual axis proportional control handle for primary boom up/down and turntable rotate left/right functions

Move the control handle up and the primary boom will raise. Move the control handle down and the primary boom will lower. Move the control handle to the right and the turntable will rotate to the right. Move the control handle to the left and the turntable will rotate to the left.



Controls

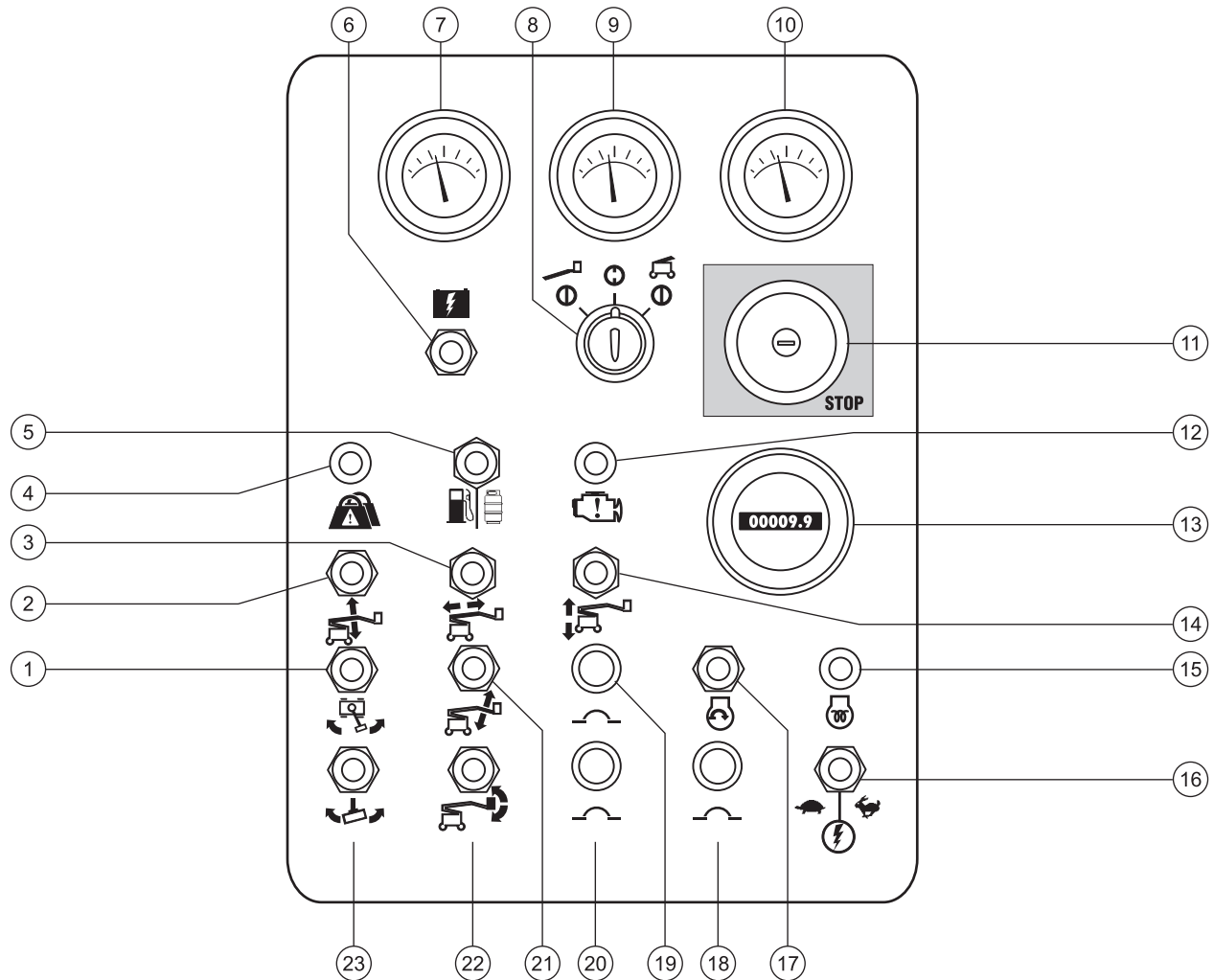

Ground Control Panel

- | | | | |
|----|---|----|--|
| 1 | Turntable rotate switch | 12 | Gasoline/LPG models: Check engine light |
| 2 | Primary boom up/down switch | 13 | Hourmeter |
| 3 | Primary boom extend/retract switch | 14 | Secondary boom up/down switch |
| 4 | Platform overload indicator light | 15 | Deutz Diesel models: Glow plug switch (option) |
| 5 | Gasoline/LPG models: Fuel select switch | 16 | Function enable switch |
| 6 | Auxiliary power switch | 17 | Engine start switch |
| 7 | Gasoline/LPG models: Water temperature gauge (option)
Deutz Diesel models: Oil temperature gauge | 18 | 15A breaker for engine electrical circuits |
| 8 | Key switch for platform/off/ground selection | 19 | 20A breaker for oil cooler and options |
| 9 | Oil pressure gauge (option) | 20 | 15A breaker for control electrical circuits |
| 10 | Voltage gauge (option) | 21 | Jib boom up/down switch |
| 11 | Red Emergency Stop button | 22 | Platform level switch |
| | | 23 | Platform rotate switch |

Controls

Ground Control Panel

1 Turntable rotate switch

Move the turntable rotate switch to the right and the turntable will rotate to the right. Move the turntable rotate switch to the left and the turntable will rotate to the left.



2 Primary boom up/down switch

Move the primary boom up/down switch up and the boom will raise. Move the primary boom up/down switch down and the boom will lower.

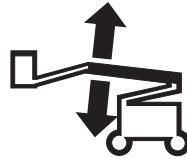

3 Primary boom extend/retract switch

Move the primary boom extend/retract switch to the right and the boom will retract. Move the boom extend/retract switch to the left and the boom will extend.



4 Platform overload indicator light

Light flashing indicates the platform is overloaded and no functions will operate. Remove weight until the light goes off.

5 Gasoline/LPG models: Fuel select switch

Move the fuel select switch to the gasoline position to select gasoline. Move the fuel select switch to the LPG position to select LPG.

6 Auxiliary power switch

Use auxiliary power if the primary power source (engine) fails.

Simultaneously hold the auxiliary power switch to either side and activate the desired function.

7 Gasoline/LPG models: Water temperature gauge (option)

Diesel models: Water temperature gauge

8 Key switch for platform/off/ground selection

Turn the key switch to the platform position and the platform controls will operate. Turn the key switch to the off position and the machine will be off. Turn the key switch to the ground position and the the ground controls will operate.

9 Oil pressure gauge (option)

10 Voltage gauge (option)

11 Red Emergency Stop button

Push in red Emergency Stop button to the off position to stop all functions and turn the engine off. Pull out the red Emergency Stop button to the on position to operate the machine.

12 Gasoline/LPG models: Check engine light

Light on and engine stopped: Tag the machine and remove from service.

Light on and engine still running: Contact service personnel within 24 hours.

13 Hour meter

The hour meter displays the number of hours the machine has operated.

14 Secondary boom up/down switch

Move the secondary boom up/down switch up and the secondary boom will raise. Move secondary boom up/down switch down and the secondary boom will lower.



Controls

15 Diesel models: Glow plug switch (if equipped)

Move the glow plug switch to either side and hold for 3 to 5 seconds.

16 Function enable switch

Move the function enable switch to either side to enable the functions on the ground control panel to operate.

17 Engine start switch

Move the engine start switch to either side to start the engine.

18 15A breaker for engine electrical circuits

19 20A circuit breaker for oil cooler and options

20 15A breaker for control electrical circuits

21 Jib boom up/down switch

Move the jib boom switch up and the jib boom will raise.
Move the jib boom switch down and the jib boom will lower.



22 Platform level switch

Move the platform level switch up and the level of the platform will raise.
Move the platform level switch down and the level of the platform will lower.



23 Platform rotate switch

Move the platform rotate switch to the right and the platform will rotate to the right.
Move the platform rotate switch to the left and the platform will rotate to the left.



Inspections



Do Not Operate Unless:

- You learn and practice the principles of safe machine operation contained in this operator's manual.

- 1 Avoid hazardous situations.

- 2 Always perform a pre-operation inspection.**

Know and understand the pre-operation inspection before going on to the next section.

- 3 Always perform function tests prior to use.
- 4 Inspect the workplace.
- 5 Only use the machine as it was intended.

Pre-operation Inspection Fundamentals

It is the responsibility of the operator to perform a pre-operation inspection and routine maintenance.

The pre-operation inspection is a visual inspection performed by the operator prior to each work shift. The inspection is designed to discover if anything is apparently wrong with a machine before the operator performs the function tests.

The pre-operation inspection also serves to determine if routine maintenance procedures are required. Only routine maintenance items specified in this manual may be performed by the operator.

Refer to the list on the next page and check each of the items.

If damage or any unauthorized variation from factory delivered condition is discovered, the machine must be tagged and removed from service.

Repairs to the machine may only be made by a qualified service technician, according to the manufacturer's specifications. After repairs are completed, the operator must perform a pre-operation inspection again before going on to the function tests.

Scheduled maintenance inspections shall be performed by qualified service technicians, according to the manufacturer's specifications and the requirements listed in the responsibilities manual.

Inspections

Pre-operation Inspection

- Be sure that the operator's, safety and responsibilities manuals are complete, legible and in the storage container located in the platform.
- Be sure that all decals are legible and in place. See Decals section.
- Check for engine oil leaks and proper oil level. Add oil if needed. See Maintenance section.
- Check for hydraulic oil leaks and proper oil level. Add oil if needed. See Maintenance section.
- Check for engine coolant leaks and proper level of coolant. Add coolant if needed. See Maintenance section.
- Check for battery fluid leaks and proper fluid level. Add distilled water if needed. See Maintenance section.
- Check for proper tire pressure. Add air if needed. See Maintenance section.

Check the following components or areas for damage, improperly installed or missing parts and unauthorized modifications:

- Electrical components, wiring and electrical cables
- Hydraulic hoses, fittings, cylinders and manifolds
- Fuel and hydraulic tanks
- Drive and turntable motors and drive hubs
- Boom wear pads
- Tires and wheels

- Engine and related components
- Limit switches and horn
- Alarms and beacons (if equipped)
- Nuts, bolts and other fasteners
- Platform entry mid-rail or gate

Check entire machine for:

- Cracks in welds or structural components
- Dents or damage to machine
- Excessive rust, corrosion or oxidation
- Be sure that all structural and other critical components are present and all associated fasteners and pins are in place and properly tightened.
- After you complete your inspection, be sure that all compartment covers are in place and latched.

Inspections



Do Not Operate Unless:

- You learn and practice the principles of safe machine operation contained in this operator's manual.

1 Avoid hazardous situations.

2 Always perform a pre-operation inspection.

3 Always perform function tests prior to use.

Know and understand the function tests before going on to the next section.

4 Inspect the workplace.

5 Only use the machine as it was intended.

Function Test Fundamentals

The function tests are designed to discover any malfunctions before the machine is put into service. The operator must follow the step-by-step instructions to test all machine functions.

A malfunctioning machine must never be used. If malfunctions are discovered, the machine must be tagged and removed from service. Repairs to the machine may only be made by a qualified service technician, according to the manufacturer's specifications.

After repairs are completed, the operator must perform a pre-operation inspection and function tests again before putting the machine into service.

Inspections

- 1 Select a test area that is firm, level and free of obstruction.

At the Ground Controls

- 2 Turn the key switch to ground control.
- 3 Pull out the red Emergency Stop button to the on position.
- ⦿ Result: The beacon (if equipped) should flash.
- 4 Start the engine. See Operating Instructions section.

Test Emergency Stop

- 5 Push in the red Emergency Stop button to the off position.
- ⦿ Result: The engine will shut off after 2 to 3 seconds.
- 6 Pull out the red Emergency Stop button to the on position and restart the engine.

Test the Machine Functions

- 7 Do not hold the function enable switch to either side. Attempt to activate each boom and platform function toggle switch. 
- ⦿ Result: All boom and platform functions should not operate.
- 8 Hold the function enable switch to either side and activate each boom and platform function toggle switch.
- ⦿ Result: All boom and platform functions should operate through a full cycle. The descent alarm should sound while the boom is lowering.

Test the Tilt Sensor

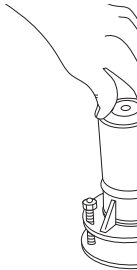
- 9 Turn the key switch to platform control. Pull out the platform red Emergency Stop button to the on position.
- 10 Open the control panel side turntable cover and locate the tilt sensor next to the control box. 
- 11 Press down one side of the tilt sensor.
- ⦿ Result: The alarm, located in the platform, should sound.

Test Auxiliary Controls

- 12 Turn the key switch to ground control and shut the engine off.
- 13 Pull out the red Emergency Stop button to the on position.
- 14 Simultaneously hold the auxiliary power switch on and activate each boom function toggle switch. 

Note: To conserve battery power, test each function through a partial cycle.

- ⦿ Result: All boom functions should operate.

Inspections

At the Platform Controls

Test Emergency Stop

15 Turn the key switch to platform control and restart the engine.

16 Push in the platform red Emergency Stop button to the off position.

⦿ Result: The engine will shut off after 2 or 3 seconds.

17 Pull out the red Emergency Stop button and restart the engine.

Test the Hydraulic Oil Return Filter

18 Move the engine idle select switch to high idle (rabbit symbol).

19 Locate and check the hydraulic filter.

⦿ Result: The indicator should be in the green area.

20 Move the engine idle select switch to foot switch activated high idle (rabbit and foot switch symbol).

Test the Horn

21 Push the horn button.

⦿ Result: The horn should sound.

Test the Foot Switch

22 Push in the platform red Emergency Stop button to the off position.

23 Pull out the red Emergency Stop button to the on position but do not start the engine.

24 Press down the foot switch and attempt to start the engine by moving the start toggle switch to either side.

⦿ Result: The engine should not start.

25 Do not press down the foot switch and restart the engine.

⦿ Result: The engine should start.

26 Do not press down the foot switch and test each machine function.

⦿ Result: The machine functions should not operate.

Test Machine Functions

27 Press down the foot switch.

28 Activate each machine function control handle or toggle switch.

⦿ Result: All boom/platform functions should operate through a full cycle.

Test the Steering

29 Press down the foot switch.

30 Press the thumb rocker switch on top of the drive control handle in the direction indicated by the blue triangle on the control panel OR slowly move the control handle in the direction indicated by the blue triangle.

⦿ Result: The steer wheels should turn in the direction that the blue triangles point on the drive chassis.

31 Press the thumb rocker switch on top of the drive control handle in the direction indicated by the yellow triangle on the control panel OR slowly move the control handle in the direction indicated by the yellow triangle.

⦿ Result: The steer wheels should turn in the direction that the yellow triangles point on the drive chassis.

Inspections

Test Drive and Braking

- 32 Press down the foot switch.
- 33 Slowly move the drive control handle in the direction indicated by the blue arrow on the control panel until the machine begins to move, then return the handle to the center position.
- ⦿ Result: The machine should move in the direction that the blue arrow points on the drive chassis, then come to an abrupt stop.
- 34 Slowly move the drive control handle in the direction indicated by the yellow arrow on the control panel until the machine begins to move, then return the handle to the center position.
- ⦿ Result: The machine should move in the direction that the yellow arrow points on the drive chassis, then come to an abrupt stop.

Note: The brakes must be able to hold the machine on any slope it is able to climb.

Test the Drive Enable System

- 35 Press down the foot switch and lower the boom to the stowed position.
- 36 Rotate the turntable until the primary boom moves past one of the non-steer wheels.
- ⦿ Result: The drive enable indicator light should come on and remain on while the boom is anywhere in the range shown.
- 37 Move the drive control handle off center.
- ⦿ Result: The drive function should not operate.



- 38 Move and hold the drive enable toggle switch to either side and slowly move the drive control handle off center.

- ⦿ Result: The drive function should operate.

Note: When the drive enable system is in use, the machine may drive in the opposite direction that the drive and steer control handle is moved.

Use the color-coded direction arrows on the platform controls and the drive chassis to identify the direction of travel.

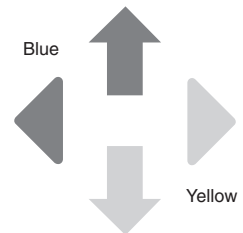

Test Limited Drive Speed

- 39 Press down the foot switch.
- 40 Raise the primary boom approximately 61 cm.
- 41 Slowly move the drive control handle to the full drive position.
- ⦿ Result: The maximum achievable drive speed with the primary boom raised should not exceed 30 cm per second.
- 42 Lower the primary boom to the stowed position.
- 43 Extend the primary boom approximately 61 cm.
- 44 Slowly move the drive control handle to the full drive position.
- ⦿ Result: The maximum achievable drive speed with the primary boom extended should not exceed 30 cm per second.

Inspections

45 Retract the primary boom to the stowed position.

46 Raise the secondary boom approximately 61 cm.

47 Slowly move the drive control handle to the full drive position.

- ⦿ Result: The maximum achievable drive speed with the secondary boom raised should not exceed 30 cm per second.

48 Lower the secondary boom to the stowed position.

Note: If the drive speed with the primary boom raised or extended or the secondary boom raised exceeds 30 cm per second, immediately tag and remove the machine from service.

Test the Oscillate Axle (oscillating axle-equipped models)

49 Start the engine from the platform controls.

50 Drive the right steer tire up onto a 15 cm block or curb.

- ⦿ Result: The three remaining tires should stay in firm contact with the ground.

51 Drive the left steer tire up onto a 15 cm block or curb.

- ⦿ Result: The three remaining tires should stay in firm contact with the ground.

52 Drive both steer tires up onto a 15 cm block or curb.

- ⦿ Result: The non-steer tires should stay in firm contact with the ground.

Test Auxiliary Controls

53 Shut the engine off.

54 Pull out the red Emergency Stop button to the on position.

55 Press down the foot switch.

56 Simultaneously hold the auxiliary power switch on and activate each function control handle or toggle switch.

Note: To conserve battery power, test each function through a partial cycle.

- ⦿ Result: All boom and steer functions should operate. Drive functions should not operate with auxiliary power.

Test the Lift/Drive Select Function (if equipped)

57 Press down the foot switch.

58 Move the drive control handle off center and activate a boom function toggle switch.

- ⦿ Result: No boom functions should operate. The machine will move in the direction indicated on the control panel.

59 Repair any malfunctions before operating the machine.

Inspections

Test Aircraft Protection Package (if equipped)

- 60 Move the gray bumper at the bottom of the platform 10 cm in any direction.
- 61 Activate each function control handle or toggle switch.
- ⦿ Result: All boom and steer functions should not operate.
- 62 Move the function override switch to either side.
- 63 Activate each function control handle or toggle switch.
- ⦿ Result: All boom and steer functions should operate.

Inspections



Do Not Operate Unless:

- You learn and practice the principles of safe machine operation contained in this operator's manual.

- 1 Avoid hazardous situations.
- 2 Always perform a pre-operation inspection.
- 3 Always perform function tests prior to use.

4 Inspect the workplace.

Know and understand the workplace inspection before going on to the next section.

- 5 Only use the machine as it was intended.

Fundamentals

The workplace inspection helps the operator determine if the workplace is suitable for safe machine operation. It should be performed by the operator prior to moving the machine to the workplace.

It is the operator's responsibility to read and remember the workplace hazards, then watch for and avoid them while moving, setting up and operating the machine.

Workplace Inspection

Be aware of and avoid the following hazardous situations:

- drop-offs or holes
- bumps, floor obstructions or debris
- sloped surfaces
- unstable or slippery surfaces
- overhead obstructions and high voltage conductors
- hazardous locations
- inadequate surface support to withstand all load forces imposed by the machine
- wind and weather conditions
- the presence of unauthorized personnel
- other possible unsafe conditions

Inspections

Inspection for Decals with Symbols

Determine whether the decals on your machine have words or symbols. Use the appropriate inspection to verify that all decals are legible and in place.

Part No.	Decal Description	Quantity
27204	Arrow - Blue	1
27205	Arrow - Yellow	1
27206	Triangle - Blue	2
27207	Triangle - Yellow	2
28158	Label - Unleaded	1
28159	Label - Diesel	1
28160	Label - Liquid Petroleum Gas (option)	1
28174	Label - Power to Platform, 230V	2
28235	Label - Power to Platform, 115V	2
32728	Label - Generator (option)	1
40434	Label - Lanyard Anchorage	3
44981	Label - Air Line to Platform (option)	2
52965	Cosmetic - Genie Z-60/34	1
52966	Cosmetic - 4 x 2	1
52967	Cosmetic - 4 x 4	1
52968	Cosmetic - Genie Boom	1
72867	Label - Lights (option)	1
82238	Platform Control Panel	1
82240	Label - 105 dB	1
82472	Label - Crushing Hazard	4
82473	Label - Compartment Access	1
82487	Label - Read the Manual	2
82487	Label - Read the Manual, Pipe Cradle	2
82487	Label - Read the Manual, Panel Cradle	2

Part No.	Decal Description	Quantity
82548	Label - Platform Rotate	2
82589	Label - Tire Pressure	4
82601	Label - Maximum Capacity, 227 kg	1
82604	Label - Maximum Manual Force, 400 N	1
82605	Label - Collision Hazard	2
82606	Label - Shear Point	2
82646	Label - Drive Enable Patch	1
82671	Label - Weld Cable to Platform (option)	2
82673	Ground Control Panel	1
97815	Label - Lower Mid-rail	1
114166	Label - Transport Diagram	2
114244	Label - Wheel Load	4
114247	Label - Fall Hazard	1
114248	Label - Tip-over Hazard, Tilt Alarm	1
114251	Label - Explosion Hazard	1
114252	Label - Tip-over Hazard, Limit Switches	2
114277	Label - Belt Routing, Ford models	1
133067	Label - Electrocution Hazard	2
133189	Label - Tire Pressure, High Flotation	4

Inspections

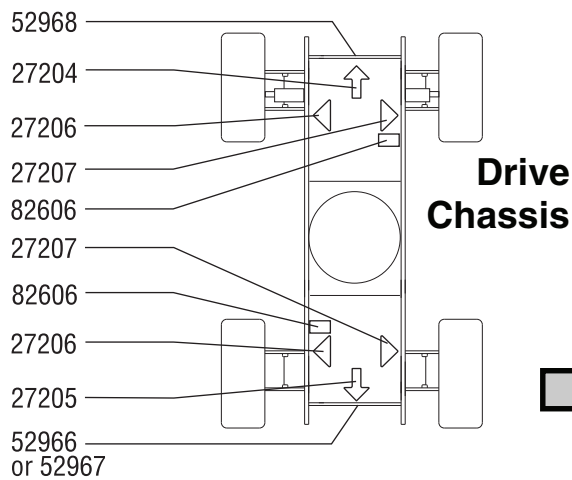
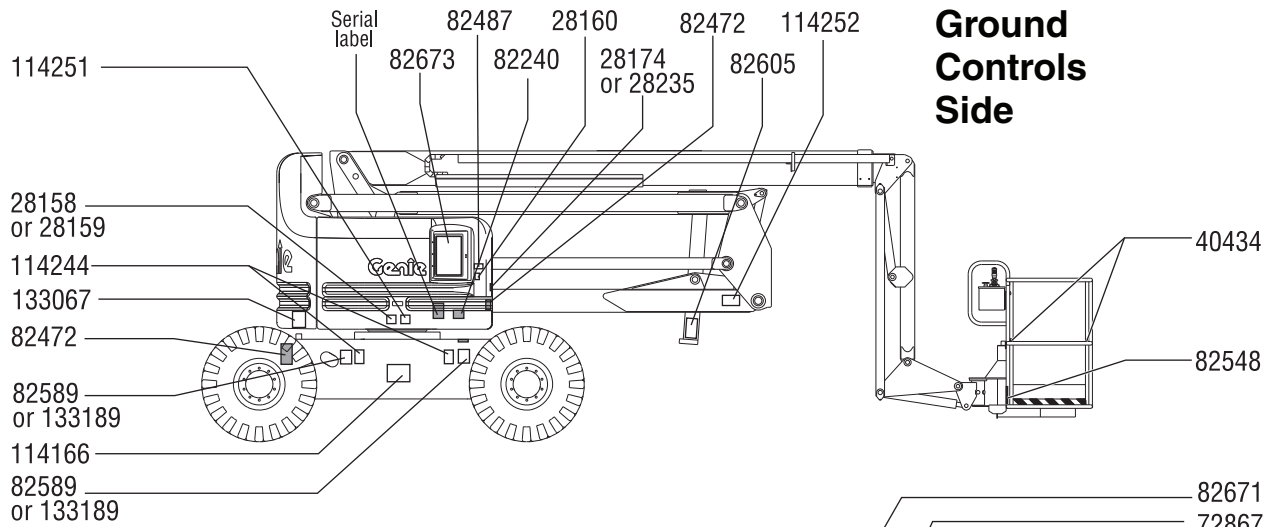

Platform

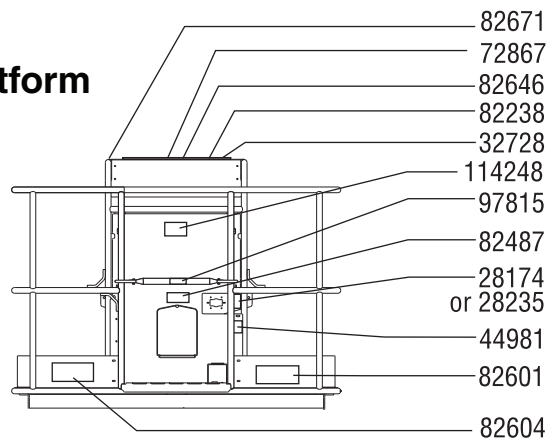

■ Shading indicates decal is hidden from view, i.e. under covers

Engine Side

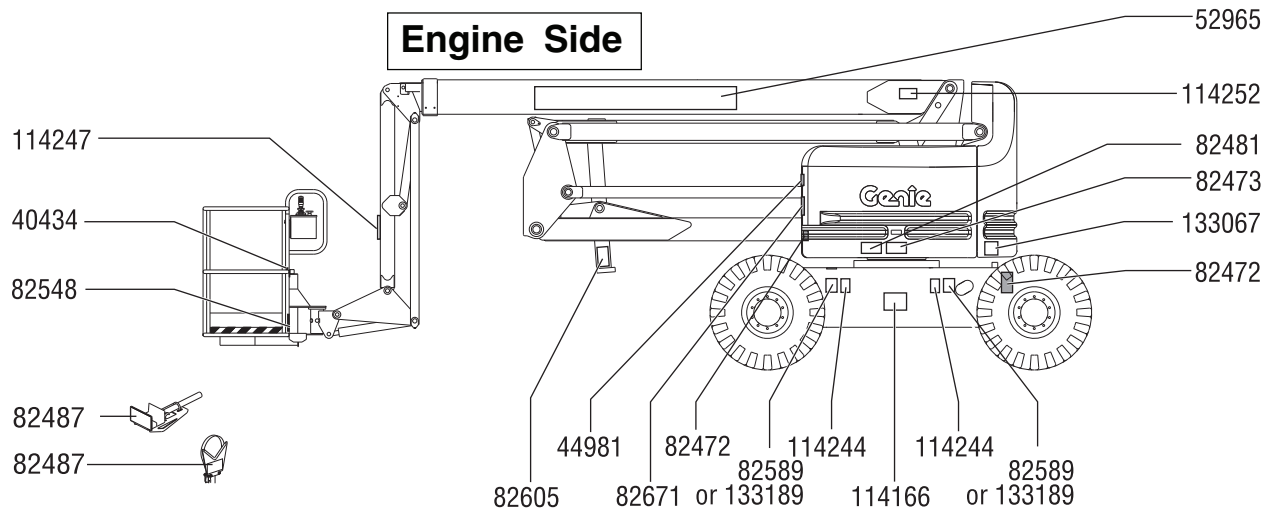

Operating Instructions



Do Not Operate Unless:

- You learn and practice the principles of safe machine operation contained in this operator's manual.
 - 1 Avoid hazardous situations.
 - 2 Always perform a pre-operation inspection.
 - 3 Always perform function tests prior to use.
 - 4 Inspect the workplace.
 - 5 Only use the machine as it was intended.**

Fundamentals

The Operating Instructions section provides instructions for each aspect of machine operation. It is the operator's responsibility to follow all the safety rules and instructions in the operator's, safety and responsibilities manuals.

Using the machine for anything other than lifting personnel, along with their tools and materials, to an aerial work site is unsafe and dangerous.

Only trained and authorized personnel should be permitted to operate a machine. If more than one operator is expected to use a machine at different times in the same work shift, they must all be qualified operators and are all expected to follow all safety rules and instructions in the operator's, safety and responsibilities manuals. That means every new operator should perform a pre-operation inspection, function tests, and a workplace inspection before using the machine.

Operating Instructions

Starting the Engine

- 1 At the ground controls, turn the key switch to the desired position.
- 2 Be sure both ground and platform control red Emergency Stop buttons are pulled out to the on position.

Gasoline/LPG models

- 3 Choose fuel by moving the fuel select switch to the desired position.
- 4 Move the engine start toggle switch to either side. If the engine fails to start or dies, the restart delay will disable the start switch for 3 seconds.



Diesel models

- 3 Move the glow plug switch to either side and hold for 3 to 5 seconds.
- 4 Move the engine start toggle switch to either side. If the engine fails to start or dies, the restart delay will disable the start switch for 3 seconds.

All models

If engine fails to start after 15 seconds of cranking, determine the cause and repair any malfunction. Wait 60 seconds before trying to start again.

In cold conditions, -6°C and below, warm the engine for 5 minutes before operating to prevent hydraulic system damage.

In extreme cold conditions, -18°C and below, machines should be equipped with optional cold start kits. Attempting to start the engine when temperatures are below -18°C may require the use of a booster battery.

Gasoline/LPG models: In cold conditions, -6°C and below, the machine should be started on gasoline and warmed for 2 minutes, then switched to LPG. Warm engines can be started on LPG.

Emergency Stop

Push in either ground or platform red Emergency Stop button to the off position to stop all functions and turn the engine off.

Repair any function that operates when the red Emergency Stop button is pushed in.

Selecting and operating the ground controls will override the platform red Emergency Stop button.

Auxiliary Controls

Use auxiliary power if the primary power source (engine) fails.

- 1 Turn the key switch to ground or platform control.
- 2 Pull out the red Emergency Stop button to the on position.
- 3 Press down the foot switch when operating the auxiliary controls from the platform.
- 4 Simultaneously hold auxiliary power switch on and activate the desired function.



The drive and steer functions will not operate with auxiliary power.

Operating Instructions

Operation from Ground

- 1 Turn the key switch to ground control.
- 2 Pull out the red Emergency Stop button to the on position.
- 3 Gasoline/LPG models: Choose fuel by moving the fuel select switch to the desired position.
- 4 Start the engine.

To Position Platform

- 1 Hold the function enable switch to either side.
- 2 Move the appropriate toggle switch according to the markings on the control panel.



Drive and steer functions are not available from the ground controls.

Operation from Platform

- 1 Turn the key switch to platform control.
- 2 Pull out both ground and platform red Emergency Stop buttons to the on position.
- 3 Gasoline/LPG models: Choose fuel by moving the fuel select switch to the desired position.
- 4 Start the engine. Do not press down the foot switch when starting the engine.

To Position Platform

- 1 Press down the foot switch.
- 2 Slowly move the appropriate function control handle or toggle switch according to the markings on the control panel.

To Steer

- 1 Press down the foot switch.
- 2 Slowly move the control handle in the direction indicated by blue or yellow triangles
OR press the thumb rocker switch located on top of the drive control handle.

Use the color-coded direction triangles on the platform controls and the drive chassis to identify the direction the wheels will turn.

To Drive

- 1 Press down the foot switch.
- 2 Increase speed: Slowly move the drive control handle off center.

Decrease speed: Slowly move the drive control handle toward center.

Stop: Return the drive control handle to center or release the foot switch.

Use the color-coded direction arrows on the platform controls and the drive chassis to identify the direction the machine will travel.

Machine travel speed is restricted when the booms are raised.

Operating Instructions

Driving on a slope

Determine the uphill, downhill and side slope ratings for the machine and determine the slope grade.



Maximum slope rating,
platform downhill (gradeability):
2WD: 25% (14°)
4WD: 40% (22°)



Maximum slope rating,
platform uphill:
2WD: 20% (11°)
4WD: 30% (17°)



Maximum side slope rating:
25% (14°)

Note: Slope rating is subject to ground conditions and adequate traction. The term gradeability applies to the platform downhill configuration only.

Be sure the boom is below horizontal and the platform is between the non-steer wheels.

Move the drive speed select switch to machine on incline symbol.

To determine the slope grade:

Measure the slope with a digital inclinometer OR use the following procedure.

You will need:

- carpenter's level
- straight piece of wood, at least 1 m long
- tape measure

Lay the piece of wood on the slope.

At the downhill end, lay the level on the top edge of the piece of wood and lift the end until the piece of wood is level.

While holding the piece of wood level, measure the vertical distance from the bottom of the piece of wood to the ground.

Divide the tape measure distance (rise) by the length of the piece of wood (run) and multiply by 100.

Example:

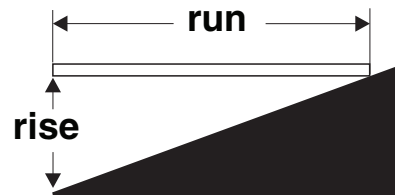

Piece of wood = 3.6 m

Run = 3.6 m

Rise = 0.3 m

$0.3 \text{ m} \div 3.6 \text{ m} = 0.083 \times 100 = 8.3\% \text{ grade}$

If the slope exceeds the maximum uphill, downhill or side slope rating, then the machine must be winched or transported up or down the slope. See Transport and Lifting section.

Operating Instructions

Drive Enable

Light on indicates that the boom has moved just past either non-steer wheel and the drive function has been interrupted.



To drive, hold the drive enable switch to either side and slowly move the drive control handle off center.

Be aware that the machine may move in the opposite direction that the drive and steer controls are moved.

Always use the color-coded direction arrows on the platform controls and the drive chassis to identify the direction the machine will travel.

Drive Speed Select



- Machine on incline symbol: Low range operation for inclines
- Machine on level surface symbol: High range operation for maximum drive speed

Engine Idle Select (rpm)

When the foot switch is not pressed, the engine will idle at the lowest rpm.

- Turtle symbol: Foot switch activated low idle
- Rabbit symbol: Foot switch activated high idle



Generator (if equipped)

To start the generator, move the generator toggle switch to the on position.

Plug a power tool into the power to platform GFCI outlet.

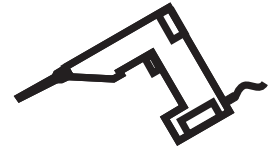

To turn off the generator, move the generator toggle switch to the off position.

Note: Machine functions will not operate while the generator is running and the foot switch is not pressed down. When the foot switch is pressed down, the generator will turn off and the machine functions will operate.

Platform Overload Indicator Light



Light flashing indicates the platform is overloaded and no functions will operate.

Remove weight from the platform until the light goes off.

Machine Not Level Indicator Light (if equipped)



Light on indicates the machine is not level. The tilt alarm will be sounding when this light is on. Move the machine to a firm level surface.

Operating Instructions

Check Engine Light (if equipped)



Light on and engine stopped: Tag the machine and remove from service.

Light on and engine still running: Contact service personnel within 24 hours.

Aircraft Protection Package (if equipped)

If the platform bumpers come in contact with aircraft components, the machine will shut down and no functions will operate.

Move the function override toggle switch to either side to operate the machine.

After Each Use

- 1 Select a safe parking location—firm level surface, clear of obstruction and traffic.
- 2 Retract and lower the boom to the stowed position.
- 3 Rotate the turntable so that the boom is between the non-steer wheels.
- 4 Turn the key switch to the off position and remove the key to secure from unauthorized use.
- 5 Chock the wheels.

Operating Instructions

Pipe Cradle Instructions

The pipe cradle assembly consists of 2 pipe cradles positioned at either side of the platform and mounted to the guardrails with U-bolts.

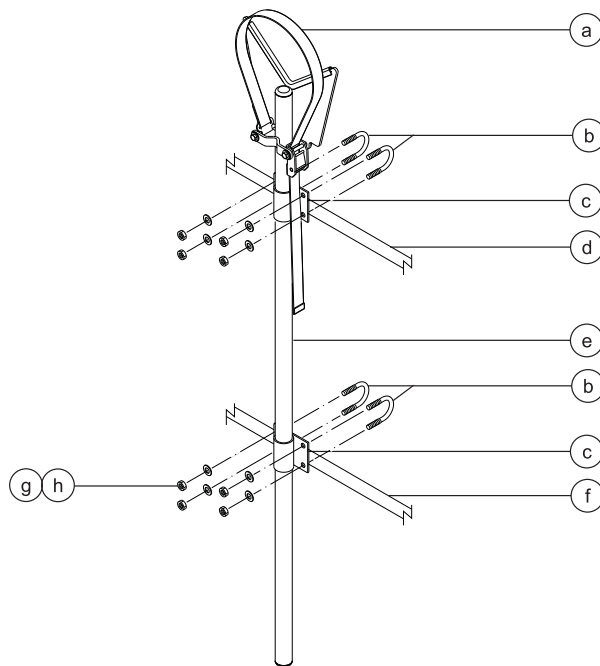

- | | |
|--------------------------|-----------------------------------|
| a strap | e pipe cradle weldment |
| b U-bolts | f middle platform railing |
| c pipe cradle mount | g flat washers |
| d upper platform railing | h $\frac{3}{8}$ -inch nylock nuts |

Observe and Obey:

- Pipe cradles must be installed on the inside of the platform.
- Pipe cradles must not obstruct the platform controls or the platform entrance.
- The bottom of the pipe cradle tube must rest on the platform floor.
- Be sure the platform is level before installing a pipe cradle.

Pipe Cradle Installation

- 1 Install a pipe cradle on each side of the platform. Refer to the illustration on the left. Make sure the bottom of the pipe cradle tube rests on the platform floor.
- 2 Install two U-bolts from the outside of the platform rails through each pipe cradle mount.
- 3 Secure each U-bolt with 2 washers and 2 nuts.

Operating Instructions

Pipe Cradle Operation

- 1 Be sure the pipe cradle assembly and installation instructions have been followed properly and that the pipe cradles are secured to the platform railings.
- 2 Place the load so that it rests in both pipe cradles. The length of the load should be parallel with the length of the platform.
- 3 Center the load in the pipe cradles.
- 4 Secure the load to each pipe cradle. Pass the nylon strap over the load. Depress the buckle and slide the strap through. Tighten the strap.
- 5 Gently push and pull on the load to make sure the pipe cradles and load are secure.
- 6 Keep the load secured when the machine is moving.

⚠ Tip-over hazard. The weight of the pipe cradle assembly and the load in the pipe cradles will reduce the rated platform capacity of the machine and must be factored into the total platform load.

⚠ Tip-over hazard. The weight of the pipe cradle assembly and the load in the pipe cradles may limit the maximum number of occupants in the platform.

Maximum Pipe Cradle Capacity	
All models	90.7 kg
Pipe Cradle Assembly Weight	
	9.5 kg

Operating Instructions

Panel Cradle Assembly

- 1 Apply the warning decal to the front of each panel cradle (if needed).
- 2 Install rubber bumper 1 in the panel cradle base. See the illustration.
- 3 Secure the bumper with 2 high profile lock nuts and 2 washers.

Panel Cradle Installation

- 1 Insert the hook piece through the slots in the panel cradle base.
- 2 Hook the panel cradle to the bottom platform tube in the desired location.
- 3 Install rubber bumper 2 through the panel cradle base and the hook piece. See the illustration.
- 4 Secure with 2 low profile lock nuts.
- 5 If the panel cradle is installed at a platform floor support tube, insert the U-bolt through the floor, around the tube and into the panel cradle base.
- 6 Secure the U-bolt with 2 nuts and 2 washers. Proceed to step 9.
- 7 If the panel cradle is not installed at a platform floor support tube, use the aluminum tube provided.
- 8 Place the tube between the panel cradle and the platform floor. Insert the U-bolt through the floor, around the tube and into the panel cradle base.
- 9 Repeat above for the second set of parts.

Installation of Padding

- 1 Install the 2 pieces of padding on the platform rails. Position the padding to protect the panels from contact with the platform rails.

Installation of Strap

- 1 Open the clamp and install it around a vertical platform rail tube.
- 2 Insert a bolt with a washer through one side of the clamp.
- 3 Install the strap assembly end plate onto the bolt.
- 4 Insert the bolt through the other side of the clamp.
- 5 Secure with a washer and a nut. Do not over-tighten. The strap assembly end plate should be able to slide on the platform rail.

Operating Instructions

Panel Cradle Operation

- 1 Secure both panel cradles to the platform.
- 2 Place the load so that it rests in both panel cradles.
- 3 Center the load on the platform.
- 4 Secure the load to the platform using the strap. Tighten the strap.

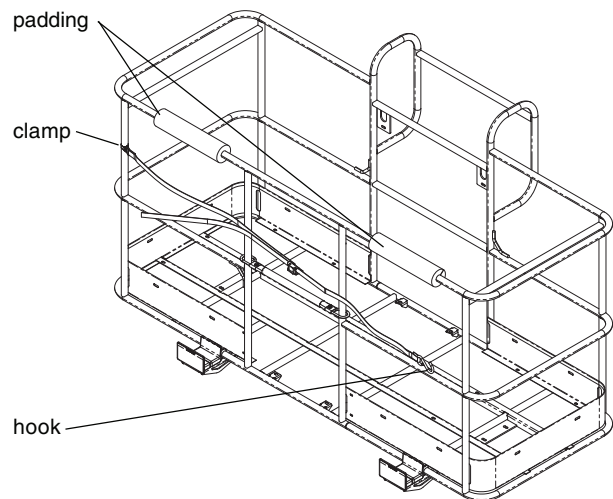
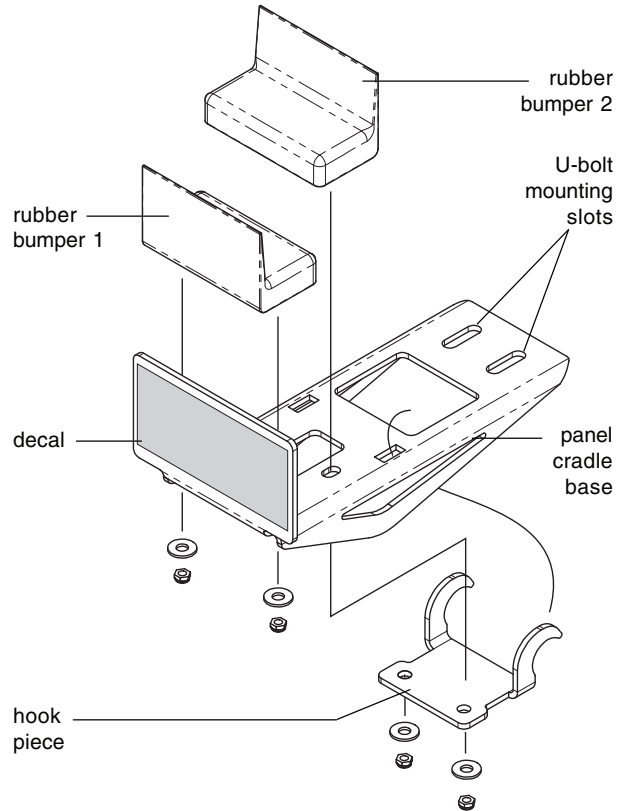

Transport and Lifting Instructions



Observe and Obey:

- ☑ Genie Industries provides this securement information as a recommendation. Drivers are solely responsible for making sure machines are properly secured and the correct trailer is selected pursuant to US Department of Transportation regulations, other localized regulations, and their company policy.
- ☑ Genie customers needing to containerize any lift or Genie product should source a qualified freight forwarder with expertise in preparing, loading and securing construction and lifting equipment for international shipment.
- ☑ Only qualified aerial lift operators should move the machine on or off the truck.
- ☑ The transport vehicle must be parked on a level surface.
- ☑ The transport vehicle must be secured to prevent rolling while the machine is being loaded.
- ☑ Be sure the vehicle capacity, loading surfaces and chains or straps are sufficient to withstand the machine weight. Genie lifts are very heavy relative to their size. See the serial label for the machine weight. See the Inspections section for the serial label location.
- ☑ Be sure the turntable is secured with the turntable rotation lock before transporting. Be sure to unlock the turntable for operation.
- ☑ Do not drive the machine on a slope that exceeds the uphill, downhill or side slope rating. See Driving on a Slope in the Operating Instructions section.
- ☑ If the slope of the transport vehicle bed exceeds the uphill or downhill maximum slope rating, the machine must be loaded and unloaded using a winch as described. See the Specifications section for the slope ratings.

Free-wheel Configuration for Winching

Chock the wheels to prevent the machine from rolling.

Release the non-steer wheel brakes by turning over the drive hub disconnect caps (see below).

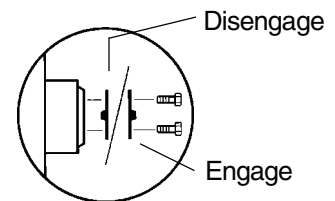

Be sure the winch line is properly secured to the drive chassis tie points and the path is clear of all obstructions.

Reverse the procedures described to re-engage the brakes.

Note: Towing the Genie Z-60/34 is not recommended. If the machine must be towed, do not exceed 2 mph / 3.2 km/h.

Transport and Lifting Instructions

⚠ Securing to Truck or Trailer for Transit

Always use the turntable rotation lock pin each time the machine is transported.

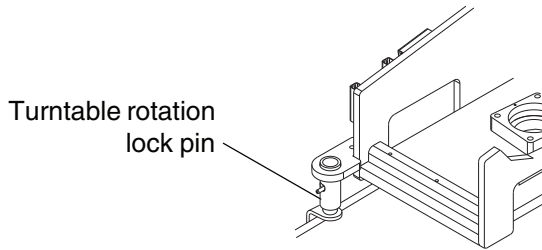

Turn the key switch to the off position and remove the key before transporting.

Inspect the entire machine for loose or unsecured items.

Securing the Chassis

Use chains of ample load capacity.

Use a minimum of 5 chains.

Adjust the rigging to prevent damage to the chains.

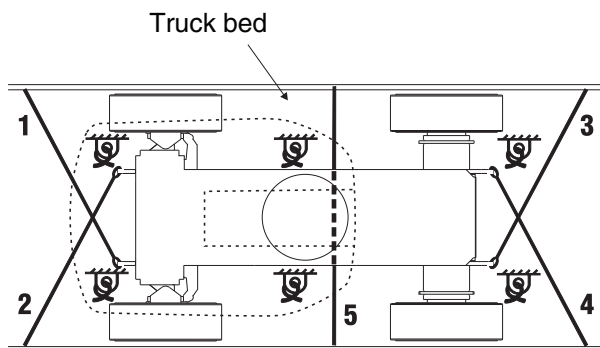

Securing the Platform

Make sure the jib and platform are in the stowed position.

Place a wooden block under the platform rotator. Do not allow the block to contact the platform cylinder.

Secure the platform with a nylon strap placed through the lower platform support. Do not use excessive downward force when securing the boom section.

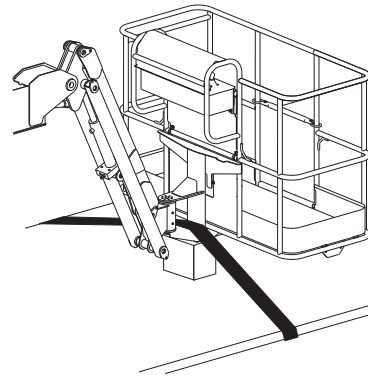

Transport and Lifting Instructions



Observe and Obey:

- ☑ Only qualified riggers should rig and lift the machine.
- ☑ Be sure the crane capacity, loading surfaces and straps or lines are sufficient to withstand the machine weight. See the serial label for the machine weight.

Lifting Instructions

Fully lower and retract the boom. Move the jib perpendicular with the ground. Remove all loose items on the machine.

Use the turntable rotation lock to secure the turntable.

Determine the center of gravity of your machine using the picture on this page.

Attach the rigging only to the designated lifting points on the machine. There are four lifting points on the chassis.

Adjust the rigging to prevent damage to the machine and to keep the machine level.

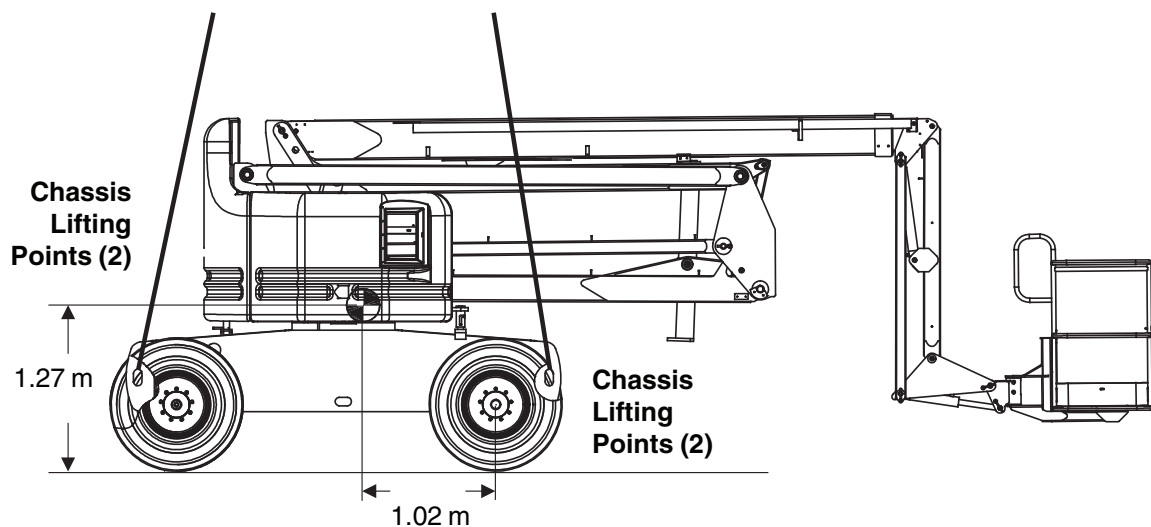

Maintenance



Observe and Obey:

- Only routine maintenance items specified in this manual shall be performed by the operator.
- Scheduled maintenance inspections shall be completed by qualified service technicians, according to the manufacturer's specifications and the requirements specified in the responsibilities manual.
- Use only Genie approved replacement parts.

Maintenance Symbols Legend

The following symbols have been used in this manual to help communicate the intent of the instructions. When one or more of the symbols appear at the beginning of a maintenance procedure, it conveys the meaning below.



Indicates that tools will be required to perform this procedure.



Indicates that new parts will be required to perform this procedure.



Indicates that a cold engine is required before performing this procedure.

Check the Engine Oil Level



Maintaining the proper engine oil level is essential to good engine performance and service life. Operating the machine with an improper oil level can damage engine components.

Note: Check the oil level with the engine off.

- 1 Check the oil dipstick. Add oil as needed.

Perkins 404-22 Engine

Oil type	15W-40
Oil type - cold conditions	5W-40

Ford DSG-423 EFI Engine (EPA Compliant)

Oil type	5W-20
----------	-------

Deutz F3L 2011F Engine (Tier II)

Oil type	15W-40
Oil type - cold conditions	5W-30

Maintenance

Check the Hydraulic Oil Level



Maintaining the hydraulic oil at the proper level is essential to machine operation. Improper hydraulic oil levels can damage hydraulic components. Daily checks allow the inspector to identify changes in oil level that might indicate the presence of hydraulic system problems.

- 1 Be sure that the boom is in the stowed position, then visually inspect the sight gauge located on the side of the hydraulic oil tank. The hydraulic oil level should be within the top 5 cm of the sight gauge.
- 2 Add oil as needed.

Hydraulic oil specifications

Hydraulic oil type	Chevron Rykon Premium MV equivalent
--------------------	--

Check the Engine Coolant Level - Ford and Perkins Models



Maintaining the engine coolant at the proper level is essential to engine service life. Improper coolant level will affect the engine's cooling capability and damage engine components. Daily checks will allow the inspector to identify changes in coolant level that might indicate cooling system problems.

⚠ Burn hazard. Beware of hot engine parts and coolant. Contact with hot engine parts and/or coolant may cause severe burns.

- 1 Check the fluid level in the coolant recovery tank. The fluid level should be at the FULL mark.
- 2 Add fluid as needed.

Note: Do not remove the radiator cap.

Maintenance

Check the Batteries



Proper battery condition is essential to good engine performance and operational safety. Improper fluid levels or damaged cables and connections can result in engine component damage and hazardous conditions.

- ⚠ **Electrocution hazard.** Contact with hot or live circuits may result in death or serious injury. Remove all rings, watches and other jewelry.
- ⚠ **Bodily injury hazard.** Batteries contain acid. Avoid spilling or contacting battery acid. Neutralize battery acid spills with baking soda and water.

- 1 Put on protective clothing and eye wear.
- 2 Be sure that the battery cable connections are tight and free of corrosion.
- 3 Be sure that the battery hold-down bracket is secure.

Note: Adding terminal protectors and a corrosion preventative sealant will help eliminate corrosion on the battery terminals and cables.

Check the Tire Pressure



- ⚠ **Tip-over hazard.** An over-inflated tire can explode which may compromise machine stability and cause the machine to tip over.
- ⚠ **Tip-over hazard.** The use of temporary flat tire repair products may lead to tire failure which could compromise machine stability and cause the machine to tip over.
- ⚠ **Bodily injury hazard.** An over-inflated tire can explode and may cause death or serious injury.

Note: This procedure does not need to be performed on machines equipped with foam-filled tires.

- 1 Check each tire with an air pressure gauge and add air as needed.

Tire pressure	4.5 bar
High flotation tire pressure	4.5 bar

Maintenance

Scheduled Maintenance

Maintenance performed quarterly, annually and every two years must be completed by a person trained and qualified to perform maintenance on this machine according to the procedures found in the service manual for this machine.

Machines that have been out of service for more than three months must receive the quarterly inspection before they are put back into service.

Specifications

Height, working maximum	20.1 m
Height, platform maximum	18.3 m
Height, stowed maximum	2.7 m
Horizontal reach maximum	10.4 m
Width	2.5 m
Length, stowed	8.2 m
Maximum load capacity	227 kg
Maximum wind speed	12.5 m/s
Wheelbase	2.5 m
Turning radius (inside)	3.04 m
Turning radius (outside)	6.1 m
Turntable rotation (degrees)	continuous
Turntable tailswing	0
Drive speed, stowed	4.8 km/h 12.2 m/9 sec
Drive speed, raised or extended	1.0 km/h 12.2 m/40 sec
Airborne noise emissions Maximum sound level at normal operating workstations (A-weighted)	105 dB
Controls	12V DC proportional
Platform dimensions, 1.2 m (width x length)	76 cm x 1.2 m
Platform dimensions, 1.5 m (width x length)	76 cm x 1.5 m
Platform dimensions, 1.8 m (width x length)	76 cm x 1.8 m
Platform dimensions, 2.4 m (width x length)	91 cm x 2.4 m
Platform leveling	self-leveling
Platform rotation	180°
AC outlet in platform	standard
Vibration value does not exceed 2.5 m/s ²	

Hydraulic pressure, maximum (boom functions)	166 bar
System voltage	12V
Tires	15 x 19.5, 16-ply
Ground clearance	40.1 cm
Fuel tank capacity	75.7 liters
Weight (Machine weights vary with option configurations)	See Serial Label

Maximum slope rating, stowed position, 2WD

Platform downhill	25% (14°)
Platform uphill	20% (11°)
Side slope	25% (14°)

Maximum slope rating, stowed position, 4WD

Platform downhill	40% (22°)
Platform uphill	30% (17°)
Side slope	25% (14°)

Note: Slope rating is subject to ground conditions and adequate traction.

Floor loading information

Tire load, maximum	4504 kg
Tire contact pressure	4.57 kg/cm ² 448 kPa
Occupied pressure	1240 kg/m ² 12.16 kPa

Note: Floor loading information is approximate and does not incorporate different option configurations. It should be used only with adequate safety factors.

Continuous improvement of our products is a Genie policy. Product specifications are subject to change without notice or obligation.

Specifications

Z-60/34 Range of Motion

